



US008398554B2

(12) **United States Patent**  
**Degertekin**

(10) **Patent No.:** **US 8,398,554 B2**  
(45) **Date of Patent:** **Mar. 19, 2013**

(54) **HARMONIC CMUT DEVICES AND FABRICATION METHODS**

(75) Inventor: **F. Levent Degertekin**, Decatur, GA (US)

(73) Assignee: **Georgia Tech Research Corporation**, Atlanta, GA (US)

(\* ) Notice: Subject to any disclaimer, the term of this patent is extended or adjusted under 35 U.S.C. 154(b) by 453 days.

(21) Appl. No.: **12/610,334**

(22) Filed: **Nov. 1, 2009**

(65) **Prior Publication Data**

US 2010/0249605 A1 Sep. 30, 2010

**Related U.S. Application Data**

(63) Continuation of application No. 11/068,129, filed on Feb. 28, 2005, now Pat. No. 7,612,483.

(60) Provisional application No. 60/548,192, filed on Feb. 27, 2004.

(51) **Int. Cl.**

**A61B 8/14** (2006.01)  
**H04R 19/00** (2006.01)  
**H02N 2/00** (2006.01)

(52) **U.S. Cl.** ..... **600/467; 600/437; 600/459; 600/466; 310/309; 367/181**

(58) **Field of Classification Search** ..... **310/309, 310/312, 322, 334; 367/163, 174, 181; 600/437, 600/459, 466, 467, 468**

See application file for complete search history.

(56) **References Cited**

**U.S. PATENT DOCUMENTS**

4,794,384 A 12/1988 Jackson  
5,158,087 A 10/1992 Gatzke  
5,560,362 A 10/1996 Sliwa, Jr. et al.

5,585,546 A 12/1996 Gururaja et al.  
5,606,974 A 3/1997 Castellano et al.  
5,677,823 A 10/1997 Smith  
5,679,888 A 10/1997 Tohda et al.  
6,122,338 A 9/2000 Yamauchi

(Continued)

**FOREIGN PATENT DOCUMENTS**

JP S52-049688 4/1977  
JP JU56-170496 12/1981

(Continued)

**OTHER PUBLICATIONS**

Supplementary European Search Report dated Jul. 9, 2010 issued by the European Patent Office for related European Application No. EP 05724089.

(Continued)

*Primary Examiner* — Thomas M Dougherty

(74) *Attorney, Agent, or Firm* — Robert R. Elliot, Jr.; Ryan A. Schneider, Esq.; Troutman Sanders LLP

(57) **ABSTRACT**

Harmonic capacitive micromachined ultrasonic transducer (“cMUT”) devices and fabrication methods are provided. In a preferred embodiment, a harmonic cMUT device generally comprises a membrane having a non-uniform mass distribution. A mass load positioned along the membrane can be utilized to alter the mass distribution of the membrane. The mass load can be a part of the membrane and formed of the same material or a different material as the membrane. The mass load can be positioned to correspond with a vibration mode of the membrane, and also to adjust or shift a vibration mode of the membrane. The mass load can also be positioned at predetermined locations along the membrane to control the harmonic vibrations of the membrane. A cMUT can also comprise a cavity defined by the membrane, a first electrode proximate the membrane, and a second electrode proximate a substrate. Other embodiments are also claimed and described.

**15 Claims, 7 Drawing Sheets**

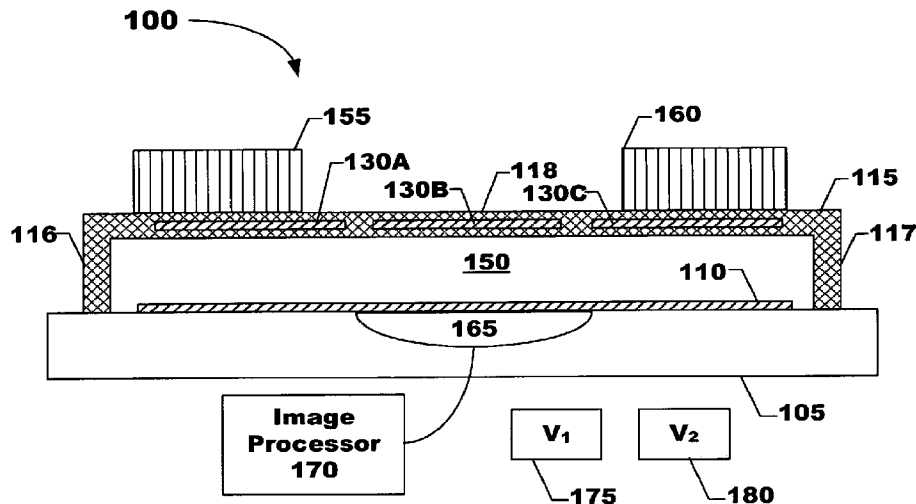

U.S. PATENT DOCUMENTS

6,122,538	A	9/2000	Sliwa, Jr. et al.	
6,201,900	B1	3/2001	Hossack et al.	
6,246,482	B1	6/2001	Kinrot et al.	
6,254,831	B1	7/2001	Barnard et al.	
6,262,946	B1	7/2001	Khuri-Yakub et al.	
6,292,435	B1	9/2001	Savord et al.	
6,314,057	B1	11/2001	Solomon et al.	
6,320,239	B1	11/2001	Eccardt et al.	
6,328,696	B1	12/2001	Fraser	
6,330,057	B1	12/2001	Lederer et al.	
6,338,716	B1	1/2002	Hossack et al.	
6,426,582	B1	7/2002	Niederer et al.	
6,441,449	B1	8/2002	Xu et al.	
6,445,109	B2	9/2002	Perçin et al.	
6,461,299	B1	10/2002	Hossack	
6,483,056	B2	11/2002	Hyman et al.	
6,504,795	B1	1/2003	Niederer et al.	
6,511,427	B1	1/2003	Sliwa, Jr. et al.	
6,514,214	B2	2/2003	Kokate et al.	
6,558,330	B1	5/2003	Ayter et al.	
6,562,650	B2	5/2003	Ladabaum	
6,571,445	B2	6/2003	Ladabaum	
6,604,425	B1	8/2003	Hsu et al.	
6,632,178	B1	10/2003	Fraser	
6,639,339	B1	10/2003	Bernstein	
6,659,954	B2	12/2003	Robinson	
6,669,644	B2	12/2003	Miller	
6,684,469	B2	2/2004	Horning et al.	
6,707,351	B2	3/2004	Gorrell	
6,714,484	B2	3/2004	Ladabaum et al.	
6,787,970	B2	9/2004	Shim et al.	
6,789,426	B2	9/2004	Yaralioglu et al.	
6,831,394	B2	12/2004	Baumgartner et al.	
6,853,041	B2	2/2005	Khuri-Yakub et al.	
7,030,536	B2	4/2006	Smith et al.	
7,166,486	B2	1/2007	Ohtaka et al.	
7,612,483	B2	11/2009	Degertekin	
7,762,954	B2*	7/2010	Nix et al. ....	600/459
2002/0009015	A1	1/2002	Laugharn et al.	
2002/0048219	A1	4/2002	Ladabaum et al.	
2002/0074553	A1	6/2002	Starikov et al.	
2002/0074621	A1	6/2002	Cheng et al.	
2002/0075098	A1	6/2002	Khuri-Yakub et al.	
2002/0123749	A1	9/2002	Jain et al.	
2002/0135329	A1	9/2002	Neufeld et al.	
2003/0029242	A1	2/2003	Yaralioglu et al.	
2003/0114760	A1	6/2003	Robinson	
2004/0002655	A1	1/2004	Bolorforosh et al.	
2004/0075364	A1	4/2004	Mehta	
2004/0085858	A1	5/2004	Khuri-Yakub et al.	
2004/0113524	A1	6/2004	Baumgartner et al.	
2004/0174773	A1	9/2004	Thomenius et al.	
2004/0180466	A1	9/2004	Foglietti et al.	
2004/0236223	A1	11/2004	Barnes et al.	
2004/0267134	A1	12/2004	Hossack et al.	
2005/0121734	A1	6/2005	Degertekin et al.	
2005/0177045	A1	8/2005	Degertekin et al.	
2005/0200241	A1	9/2005	Degertekin	
2005/0200242	A1	9/2005	Degertekin	
2005/0203397	A1	9/2005	Degertekin	
2006/0075818	A1	4/2006	Huang et al.	
2006/0116585	A1	6/2006	Nguyen-Dinh et al.	
2009/0182229	A1*	7/2009	Wodnicki .....	600/437

FOREIGN PATENT DOCUMENTS

JP	2000-201399	7/2000
WO	01/44765	6/2001

WO	03/011749	2/2003
WO	2004/016036	2/2004
WO	WO 2005084267	9/2005

OTHER PUBLICATIONS

Communication Relating to the Results of the Partial International Search dated Aug. 25, 2005 for PCT Application No. PCT/US2005/08259.

International Search Report and Written Opinion dated Oct. 31, 2005 for PCT Application No. PCT/US2005/08259.

International Search Report and Written Opinion dated Oct. 16, 2006 for PCT Application No. PCT/US2005/06474.

International Search Report and Written Opinion dated Dec. 27, 2006 for PCT Application No. PCT/US2005/03898.

International Search Report and Written Opinion dated Sep. 5, 2007 for PCT Application No. PCT/US2005/06408.

International Search Report and Written Opinion dated Dec. 27, 2007 for PCT Application No. PCT/US2005/06408.

International Search Report and Written Opinion dated Feb. 7, 2008 for PCT Application No. PCT/US2004/037089.

Demirci, Utkan et al., "Forward-Viewing CMUT Arrays for Medical Imaging", IEEE Transactions on Ultrasonic, Ferroelectrics, and Frequency Control, vol. 51, No. 7, Jul. 2004, pp. 886-894.

Hall, Neal A. et al., "Modeling and Design of CMUTs Using Higher Order Vibration Modes", IEEE Ultrasonic Symposium, 2004, pp. 260-263.

Jin, Xuecheng. et al., "Fabrication and Characterization of Surface Micromachined Capacitive Ultrasonic Immersion Transducers", IEEE Journal of Micromechanical Systems, vol. 8, No. 1, Mar. 1999, pp. 100-114.

Knight, Joshua G. et al., "Capacitive Micromachined Ultrasonic Transducers for Forward Looking Intravascular Imaging Arrays", IEEE Ultrasonic Symposium, 2002, pp. 1079-1082.

Knight, Joshua G. et al. "Fabrication and Characterization of cMUTs for Forward Looking Intravascular Ultrasound Imaging", IEEE Ultrasonic Symposium, 2003, pp. 577-580.

Knight, Joshua G. et al. "Low Temperature Fabrication of Immersion Capacitive Micromachined Ultrasonic Transducers on Silicon and Dielectric Substrates", IEEE Transactions on Ultrasonics . . . , vol. 51, No. 10, Oct. 2004, pp. 1324-1333.

Lee, Wook et al. "Fabrication and Characterization of a Micromachined Acoustic Sensor with Integrated Optical Readout", IEEE Journal of Selected Topics in Quantum Electronics, vol. 10, No. 3, May/June. 2004, pp. 643-651.

McLean, Jeff et al., "Capacitive Micromachined Ultrasonic Transducers with Asymmetric Membranes for Microfluidic Applications", IEEE Ultrasonic Symposium, 2001, pp. 925-928.

McLean, Jeff et al., "Interdigital Capacitive Micromachined Ultrasonic Transducers for Sensing and Pumping in Microfluidic Applications", Proceedings of the 12<sup>th</sup> International Conference on Solid State Sensors, Actuators . . . , Jun. 8-12, 2003, pp. 915-918.

McLean, Jeff et al., "CMUTs with Dual Electrode Structure for Improved Transmit and Receive Performance", IEEE Ultrasonic Symposium, 2004, pp. 501-504.

Examination Report issued by the European Patent Office dated Dec. 14, 2011, for related European Application No. 05724038.4.

Examination Report issued by the European Patent Office dated Nov. 22, 2011, for related European Application No. 05725443.5.

Supplementary European Search Report dated Apr. 7, 2011 for related European Application No. EP05724038.

Office Action dated Oct. 18, 2010 issued by the Japanese Patent Office for related Japanese Patent Application No. 2007-503069.

Decision of Refusal dated May 30, 2011, issued by the Japanese Patent Office for related Japanese Patent Application No. 2007-500802.

\* cited by examiner

FIG. 1

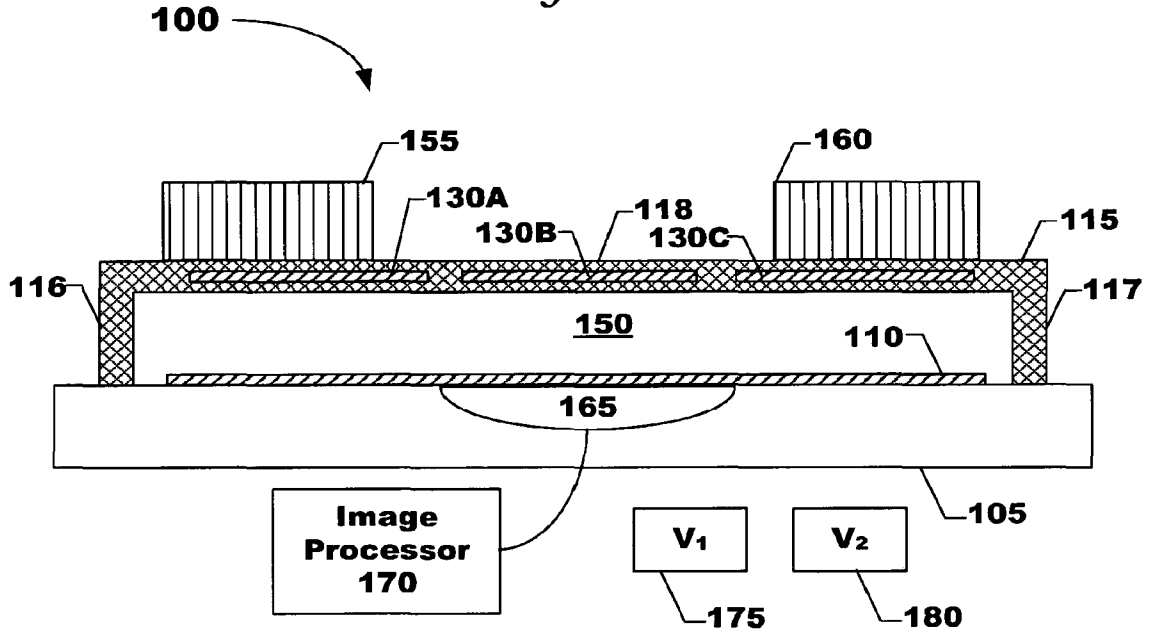

FIG. 2

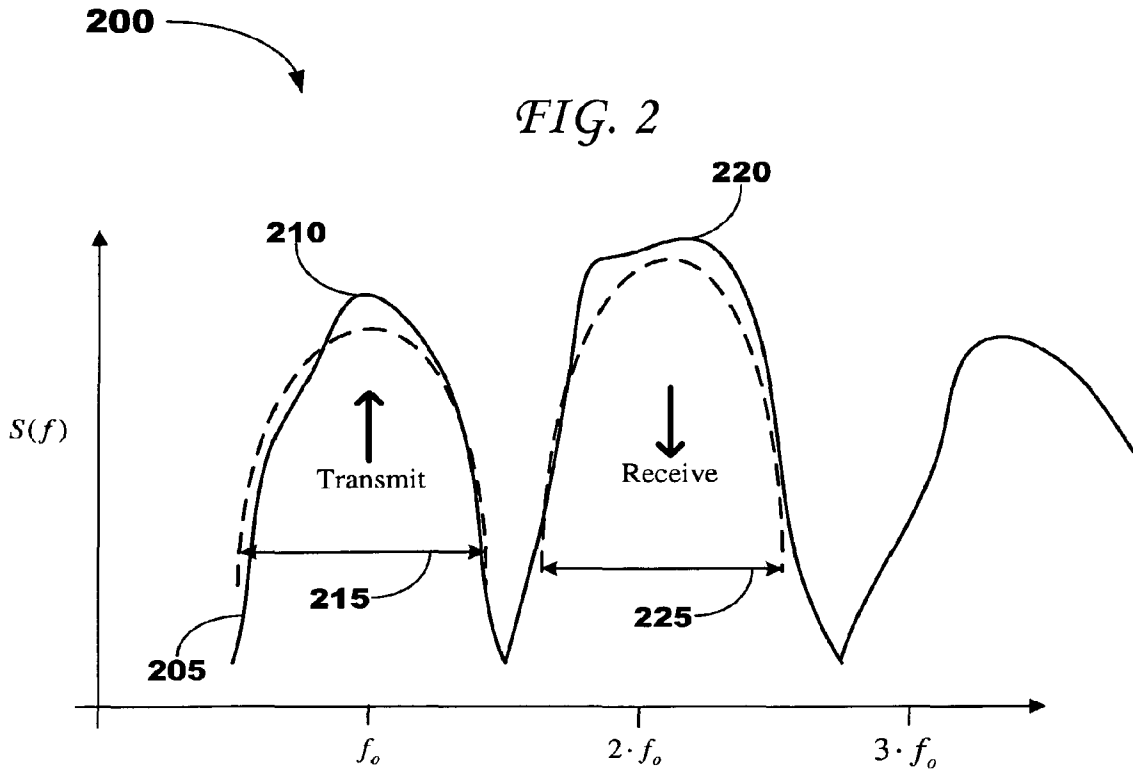
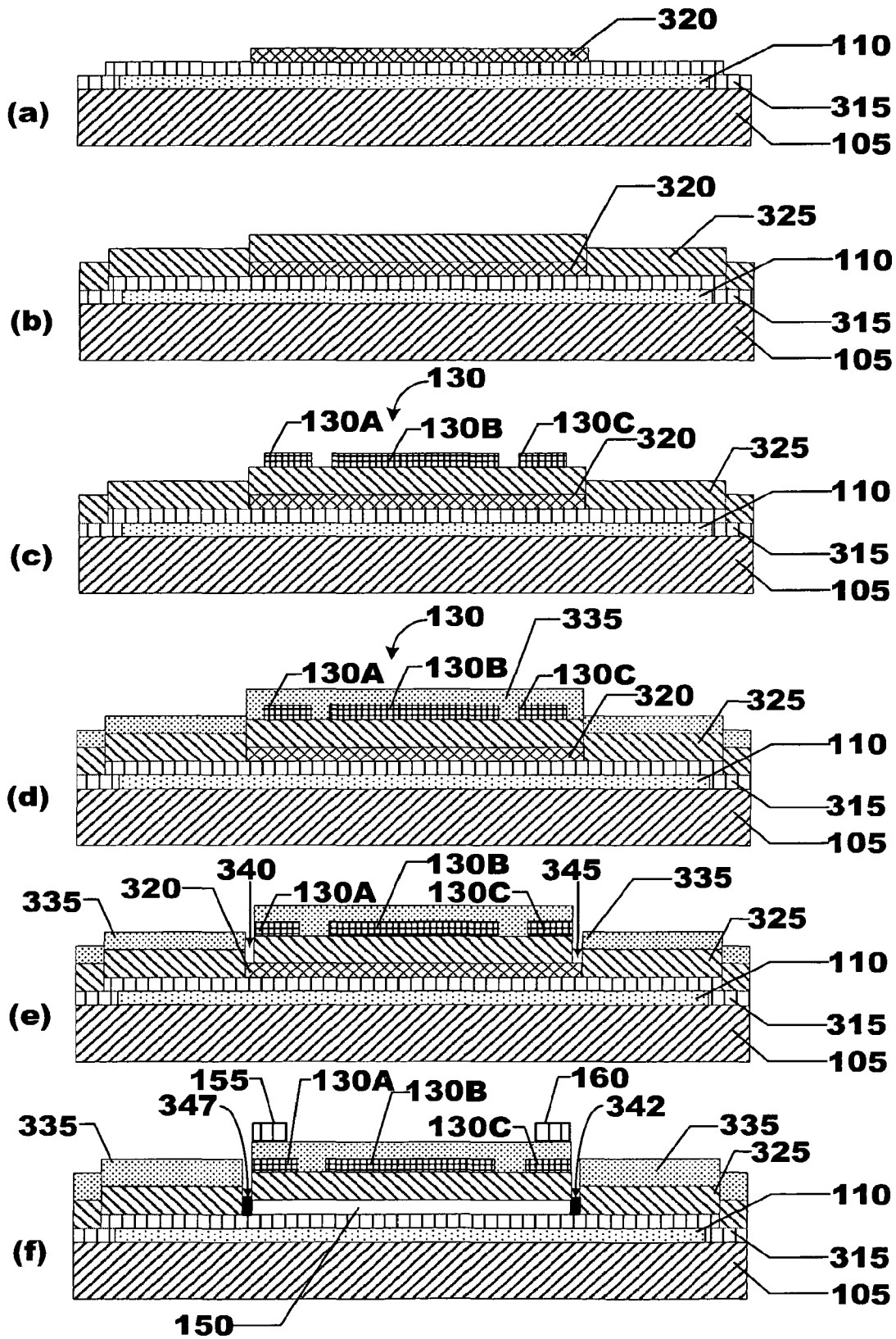

FIG. 3



400

FIG. 4

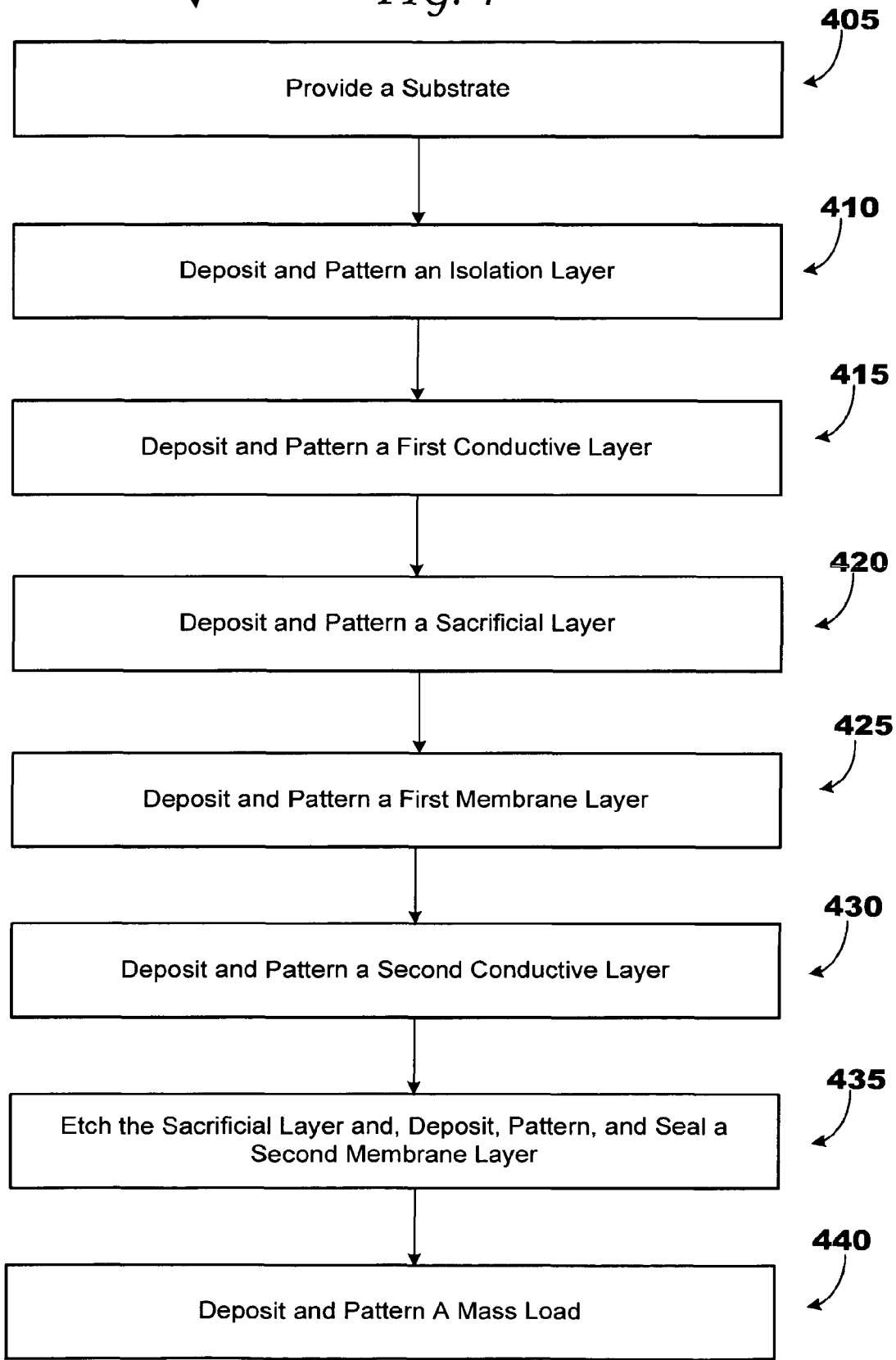

FIG. 5

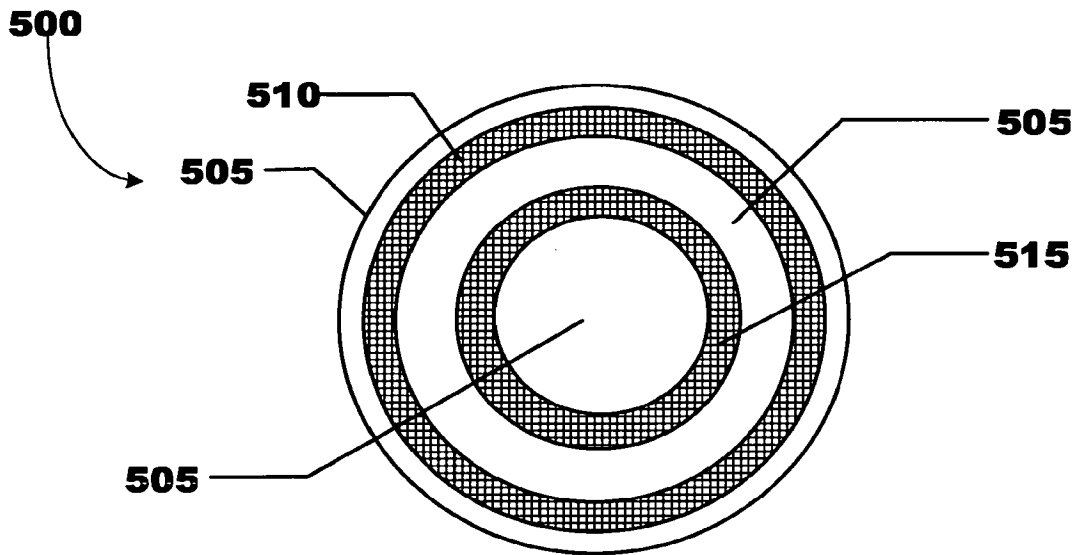
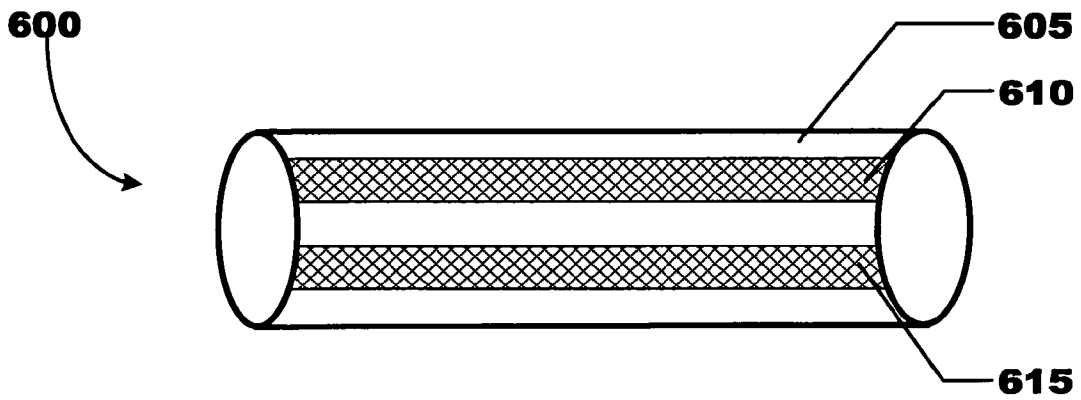

FIG. 6



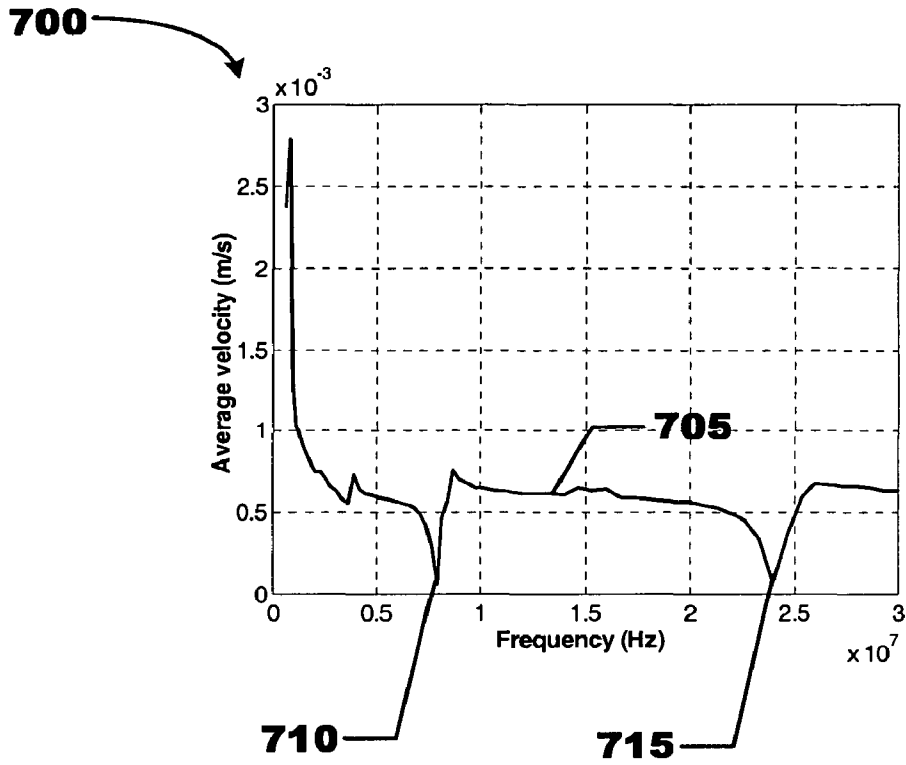

FIG. 7

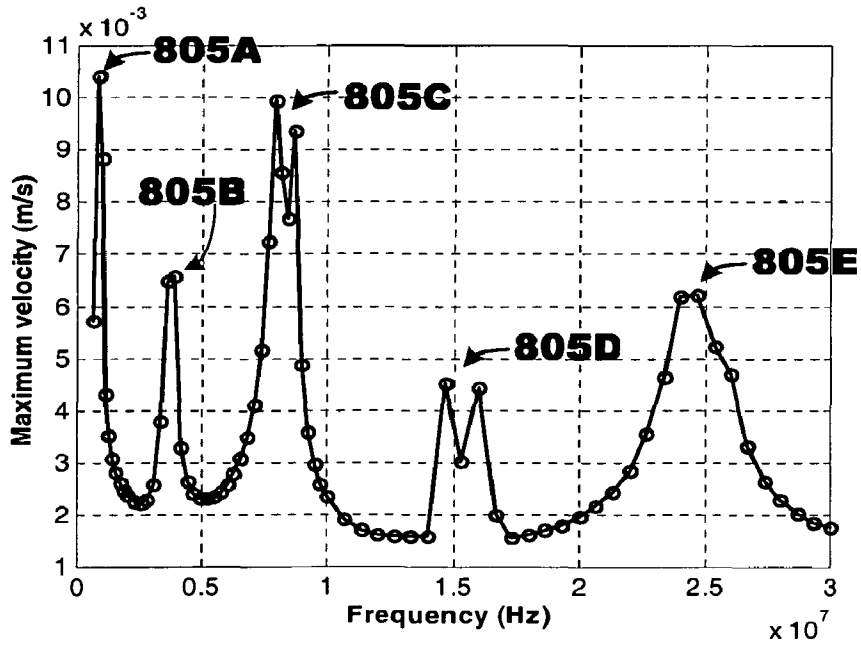

FIG. 8

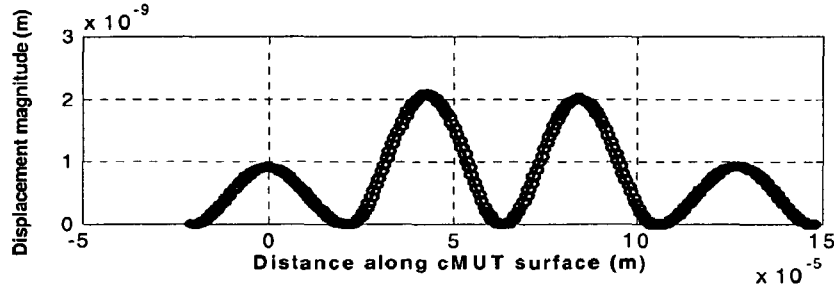

FIG. 9A

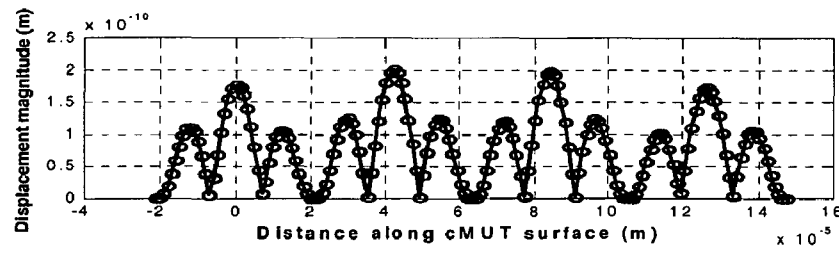

FIG. 9B

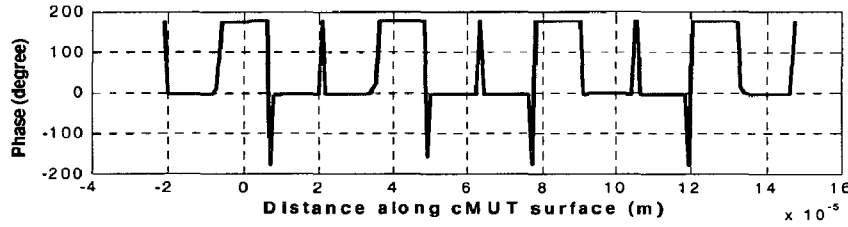

FIG. 9C

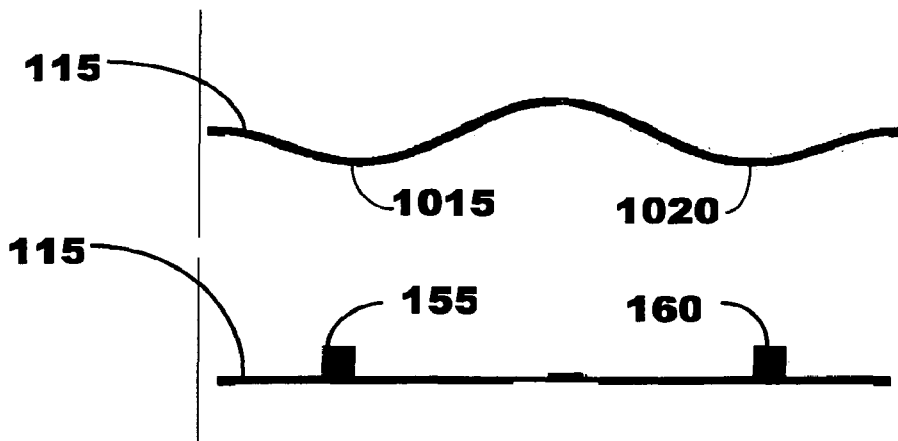

FIG. 10A

FIG. 10B

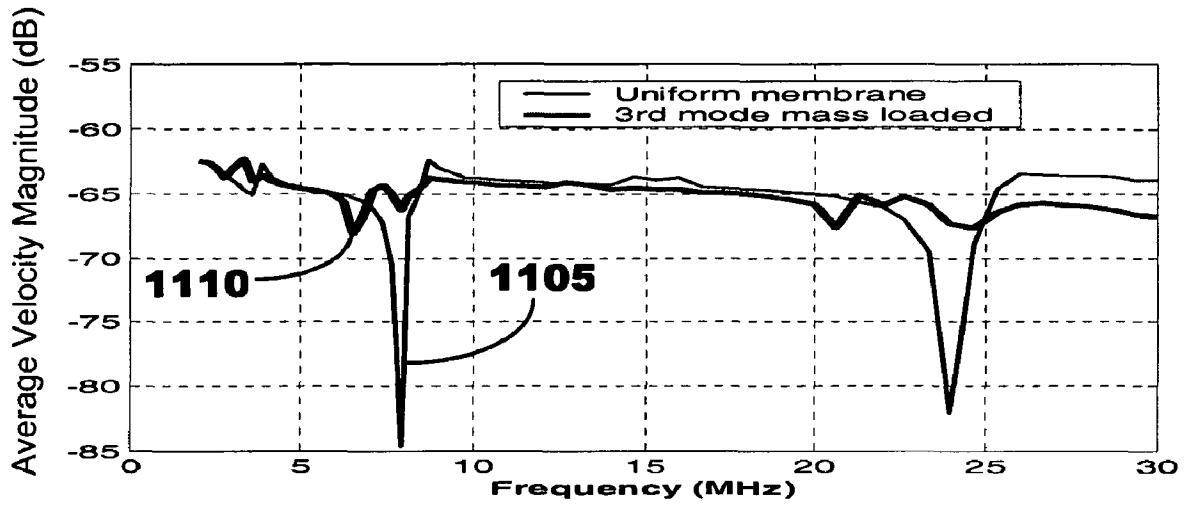

FIG. 11

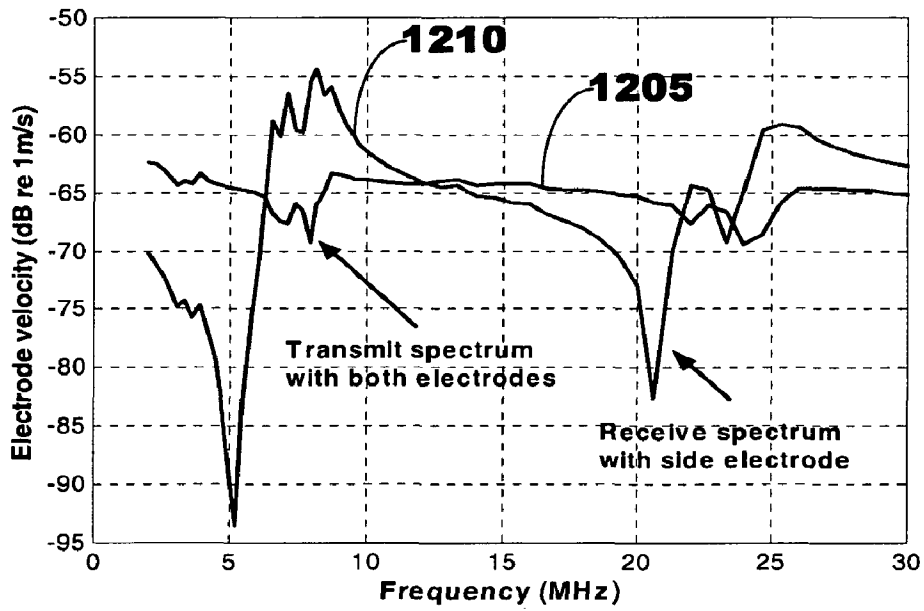

FIG. 12

## HARMONIC CMUT DEVICES AND FABRICATION METHODS

### CROSS REFERENCE TO RELATED APPLICATIONS AND PRIORITY CLAIMS

This application is a continuation of U.S. patent application Ser. No. 11/068,129, filed 28 Feb. 2005, entitled "Harmonic CMUT Devices and Fabrication Methods, which claims priority to and the benefit of U.S. Provisional Application Ser. No. 60/548,192 filed on 27 Feb. 2004. All of said patent applications are hereby incorporated herein by reference as if fully set forth below.

### TECHNICAL FIELD

Embodiments of the present invention relate generally to chip fabrication, and more particularly, to fabricating harmonic capacitive micromachined ultrasonic transducers ("cMUTs") and harmonic cMUT imaging arrays.

### BACKGROUND

Capacitive micromachined ultrasonic transducers generally combine mechanical and electronic components in very small packages. The mechanical and electronic components operate together to transform mechanical energy into electrical energy and vice versa. Because cMUTs are typically very small and have both mechanical and electrical parts, they are commonly referred to as micro-electronic mechanical systems ("MEMS") devices. cMUTs, due to their miniscule size, can be used in numerous applications in many different technical fields, including medical device technology.

One application for cMUTs within the medical device field is imaging soft tissue. Tissue harmonic imaging has become important in medical ultrasound imaging, because it provides unique information about the imaged tissue. In harmonic imaging, ultrasonic energy is transmitted from an imaging array to tissue at a center frequency ( $f_0$ ) during transmission. This ultrasonic energy interacts with the tissue in a nonlinear fashion, especially at high amplitude levels, and ultrasound energy at higher harmonics of the input frequency, such as  $2f_0$ , are generated. These harmonic signals are then received by the imaging array, and an image is formed. To have a good signal to noise ratio during harmonic imaging, ultrasonic transducers in the imaging array would preferably be sensitive around both the fundamental frequency  $f_0$  and the first harmonic frequency  $2f_0$ .

Conventional ultrasonic transducers are not capable of performing in such a manner. For example, piezoelectric transducers are not suitable for harmonic imaging applications because these transducers tend to be efficient only at a fundamental frequency ( $f_0$ ) and its odd harmonics ( $3f_0$ ,  $5f_0$ , etc.). To compensate for the odd harmonic efficiencies of piezoelectric transducers, the transducer is typically damped and several matching layers are used to create a broad band (~90% fractional bandwidth) transducer. This approach, however, requires a trade-off between sensitivity and bandwidth, since significant energy is lost due to the backing and matching layers. Additionally, conventional piezoelectric transducers and fabrication methods do not enable device manufacturers to control or adjust the vibration harmonics of conventional piezoelectric transducers.

Conventional cMUTs are also not generally configured for tissue harmonic imaging. For example, conventional cMUTs are not adapted to and do not utilize the multiple vibration modes of a cMUT membrane. Rather, conventional cMUTs,

like conventional piezoelectric transducers, have a substantially uniform circular or rectangular membrane that have only utilized the first vibration mode of the cMUT membrane. In addition, conventional cMUTs and fabrication methods do not provide cMUTs capable of having adjustable vibration modes or controllable vibration harmonics. Due to the design of conventional cMUT types, a 90% fractional bandwidth is usually desired to have a reasonable signal to noise ratio. This fractional bandwidth, however, precludes use of multiple vibration orders of a cMUT membrane for medical imaging applications. Specifically, conventional cMUT designs are not optimized to achieve higher sensitivity over a wide bandwidth or adapted to exploit multiple vibration modes of a cMUT membrane.

Therefore, there is a need in the art for a cMUT fabrication method enabling fabrication of a cMUT with an enhanced membrane to increase and enhance cMUT device performance for tissue harmonic imaging applications.

Additionally, there is a need in the art for fabricating cMUTs to utilize multiple vibration modes and multiple vibration harmonics of a membrane to increase and enhance cMUT device performance.

Additionally, there is a need in the art for a cMUT device capable of receiving and transmitting ultrasonic energy using frequencies associated with different vibration modes for a cMUT membrane.

Still yet, there is a need in the art for a cMUT device having a membrane with vibration modes that are harmonically related.

It is to the provision of such cMUT fabrication and cMUT imaging array fabrication that the embodiments of present invention are primarily directed.

### BRIEF SUMMARY OF THE INVENTION

Embodiments of the present invention comprise harmonic cMUT array transducer fabrication methods and systems. The present invention provides cMUTs for imaging applications having enhanced membranes and multiple-element electrodes for optimizing the transmission and receipt of ultrasonic energy or waves, which can be especially useful in medical imaging applications. The cMUTs of the present invention can have membranes with non-uniform mass distributions adapted to receive a predetermined frequency. The present invention also provides cMUTs having membranes that can be adapted to have vibration modes that are harmonically related. In addition, the present invention provides cMUTs having membranes capable of being fabricated such that the vibration harmonics of cMUT membranes can be adjusted to correspond with operational frequencies and associated harmonics. Still yet, the present invention provides cMUTs capable of being fabricated with electrodes located near multiple vibration mode peaks of cMUT membranes when the cMUT membranes are immersed in an imaging medium.

cMUTs can be fabricated on dielectric or transparent substrates, such as, but not limited to, silicon, quartz, or sapphire, to reduce device parasitic capacitance, thus improving electrical performance and enabling optical detection methods to be used. Additionally, cMUTs constructed according to a preferred embodiment of the present invention can be used in immersion applications such as intravascular catheters and ultrasound imaging.

Some of the present invention's embodiments preferably comprise a cMUT including a membrane and a membrane frequency adjustor for adjusting a vibration mode of the membrane. The membrane frequency adjustor can adjust the

membrane so that at least two vibration modes of the membrane are harmonically related. The membrane frequency adjustor can comprise the membrane having a non-uniform mass distribution along at least a portion of its length. The non-uniformity in mass can be provided by varying the thickness of the membrane, varying the density of the membrane, or for example, providing the membrane with a mass load proximate the membrane. The mass load can be a single mass source providing the mass non-uniformity along its length, or it can be a plurality of separate mass loads elements located in various places along the membrane.

The cMUT can include a mass load being an electrode element of the cMUT. The mass load preferably is Gold.

The plurality of mass load elements modifies the frequency response of the membrane. The membrane can have a plurality of vibration modes, and the membrane frequency adjustor can adapt the membrane so that the vibration modes of the membrane are harmonically related. The membrane can be adapted to vibrate at a fundamental frequency and the membrane frequency adjustor can adjust the membrane to vibrate at a frequency substantially equal to twice the fundamental frequency.

The present invention can further comprising a method of controlling vibration modes of a cMUT including the steps of providing a membrane, determining a target vibration frequency of the membrane, and altering the mass distribution of the membrane along at least a portion of the length of the membrane to induce the target vibration frequency of the membrane. In a preferred embodiment, the target vibration frequency of the membrane is substantially twice a fundamental frequency of the membrane. The step of altering the mass distribution of the membrane along at least a portion of the length of the membrane can comprise providing a membrane having a varying thickness along at least a portion of the length of the membrane, or providing a membrane having a varying density along at least a portion of the length of the membrane. Preferably, the membrane has a first vibration mode and a second vibration mode that is approximately twice the frequency of the first vibration mode, the membrane being adapted to transmit ultrasonic energy at the first vibration mode and receive ultrasonic energy at the second vibration mode.

A method of fabricating a cMUT according to a preferred embodiment of the present invention comprises the steps of providing a membrane and configuring the membrane to have a non-uniform mass distribution to receive energy at a predetermined frequency. The step of configuring the membrane to have a non-uniform mass distribution can include providing a plurality of mass loads proximate the membrane. A further step of adapting the membrane to transmit ultrasonic energy at a first vibration mode and receive ultrasonic energy at a second vibration mode, wherein the second vibration mode is approximately twice the frequency of the first vibration mode, can be provided. Additionally, the membrane can be adapted so that the vibration modes of the membrane are harmonically related, and a further step of positioning an electrode element proximate a vibration mode of the membrane can be added.

A preferred embodiment of the present invention comprises a membrane and a mass load proximate the membrane. The mass load can adapt the membrane to receive energy at a predetermined frequency. In addition, a plurality of mass loads can be disposed on the membrane so that the membrane has a non-uniform mass distribution along at least a portion of its length. The mass load can be part of, proximate, or positioned along the membrane. The mass load can be of different materials than the membrane. The membrane can be formed

to have regions of different thickness using the mass load to distribute the mass of the membrane so that the membrane's vibration modes are harmonically related. Alternatively, a portion of the non-uniform mass distribution of the membrane can be formed by patterning the membrane to have regions of varying thickness. The harmonic cMUT can also comprise a cavity defined by the membrane, a first electrode proximate the membrane, and a second electrode proximate a substrate. The cavity can be disposed between the first electrode and second electrode. The first electrode and the second electrode can be configured to have multiple elements.

In another preferred embodiment, a method to fabricate a cMUT can comprise providing a membrane proximate a substrate and configuring the membrane to have a non-uniform mass distribution along at least a portion of its length. A method to fabricate a cMUT can also comprise providing a sacrificial layer proximate the first conductive layer, providing a first membrane layer proximate the sacrificial layer, providing a second membrane layer proximate the second conductive layer, and removing the sacrificial layer. The first and second membrane layers can form the membrane. A cMUT fabrication method can also comprise shifting the frequency and shape of a vibration mode of the membrane and adapting the membrane to operate in a receive state to receive ultrasonic energy and a transmission state to transmit ultrasonic energy.

In yet another preferred embodiment, a method to control a harmonic cMUT can comprise determining a vibration mode of the membrane and positioning one or more mass loads on the membrane to induce a membrane vibration mode corresponding to a predetermined frequency. The harmonic cMUT can have a top electrode proximate a membrane, a bottom electrode proximate a substrate, and a cavity between the membrane and the bottom electrode. A method to control a harmonic cMUT can also include positioning a first electrode element to correspond with a vibration mode of the membrane. The first electrode element can be a part of a top electrode and/or a bottom electrode. A predetermined frequency can be substantially twice a fundamental frequency of a membrane. A membrane can have a first vibration mode and a second vibration mode that is approximately twice the frequency of the first vibration mode. The membrane can be adapted to transmit ultrasonic energy at a first vibration mode and receive ultrasonic energy at a second vibration mode.

These and other features as well as advantages, which characterize the various preferred embodiments of present invention, will be apparent from a reading of the following detailed description and a review of the associated drawings. In some instances, this application may refer to discussion of the inventors as "the present invention" but it is intended that such reference is to embodiments of the present invention as opposed to limiting the wide breadth of the inventor's invention. Thus, the claims of the present invention are not intended to be limited as such, rather only fully enabled and defined.

#### BRIEF DESCRIPTION OF THE DRAWINGS

FIG. 1 illustrates a cross-sectional view of a harmonic cMUT in accordance with a preferred embodiment of the present invention.

FIG. 2 illustrates a sample pulse-echo frequency spectrum of a harmonic cMUT in accordance with a preferred embodiment of the present invention.

FIG. 3 illustrates a fabrication process utilized to fabricate a harmonic cMUT in accordance with a preferred embodiment of the present invention.

FIG. 4 illustrates a logical flow diagram depicting a fabrication process utilized to fabricate a harmonic cMUT in accordance with a preferred embodiment of the present invention.

FIG. 5 illustrates a cMUT imaging array system comprising multiple harmonic cMUTs formed in a ring-annular array in accordance with a preferred embodiment of the present invention.

FIG. 6 illustrates a cMUT imaging array system comprising multiple harmonic cMUTs formed in a side-looking array in accordance with a preferred embodiment of the present invention.

FIG. 7 is a diagram illustrating a graph illustrating the calculated average velocity as a function of frequency over the surface of the cMUTs illustrated in FIG. 7.

FIG. 8 is a graph illustrating the calculated peak velocity amplitude as a function of frequency over the surface of the cMUT membrane illustrated in FIG. 1.

FIG. 9A is a diagram illustrating a vibration profile for the cMUT membrane illustrated in FIG. 1 at approximately 0.8 MHz.

FIG. 9B is a diagram illustrating a magnitude of the vibration profile for the cMUT membrane illustrated in FIG. 1 at approximately 8 MHz.

FIG. 9C is a diagram illustrating a phase of the vibration profile for the cMUT membrane illustrated in FIG. 1 at approximately at 8 MHz.

FIG. 10A is a diagram illustrating a cross section of a cMUT membrane vibrating at its third mode.

FIG. 10B is a diagram illustrating a cross section of a mass loads positioned along a cMUT membrane.

FIG. 11 is a diagram illustrating a comparison of an average velocity for the cMUT membrane illustrated in FIG. 1 being loaded and unloaded with mass loads.

FIG. 12 is a diagram of a sample calculated average velocity corresponding to transmit and receive electrode elements for a harmonic CMUT.

#### DETAILED DESCRIPTION OF PREFERRED EMBODIMENTS

cMUTs have been developed as an alternative to piezoelectric ultrasonic transducers, particularly for micro-scale and array applications. cMUTs are typically surface micromachined and can be fabricated into one or two-dimensional arrays and customized for specific applications. cMUTs can have performance comparable to piezoelectric transducers in terms of bandwidth and dynamic range, but are generally significantly smaller.

A cMUT typically incorporates a top electrode disposed within a membrane suspended above a conductive substrate or a bottom electrode proximate or coupled to a substrate. An adhesion layer or other layer can optionally be disposed between the substrate and the bottom electrode. The membrane can have elastic properties enabling it to fluctuate in response to stimuli. For example, stimuli may include, but are not limited to, external forces exerting pressure on the membrane and electrostatic forces applied through cMUT electrodes.

cMUTs are often used to transmit and receive acoustic waves. To transmit an acoustic wave, an AC signal and a large DC bias voltage are applied to a cMUT electrode disposed within a cMUT membrane. Alternatively, the voltages can be applied to the bottom electrode. The DC voltage can pull down the membrane to a position where transduction is efficient and the cMUT device response can be linearized. The AC voltage can set the membrane into motion at a desired

frequency to generate an acoustic wave in a surrounding medium, such as gases or fluids. To receive an acoustic wave, a capacitance change can be measured between cMUT electrodes when an impinging acoustic wave sets a cMUT membrane into motion.

The present invention provides cMUTs comprising an enhanced membrane to control the vibration harmonics of a cMUT. A cMUT membrane according to the present invention can have a non-uniform mass distribution along the length of the membrane. The membrane can have, for example, a substantially uniform thickness, but have variations in densities providing the mass distribution profile. Alternatively, the mass distribution can be provided by varying the thickness of the membrane. If the membrane is fashioned from a single material have a substantially uniform thickness and density, mass loads can also be utilized.

Controlling the mass distribution along the membrane enables the vibration harmonics of a cMUT membrane to be controlled. As an example, multiple mass loads can be proximate, a part of, or positioned along a membrane to aid in shifting or adjusting membrane vibration modes. A cMUT membrane having a non-uniform mass distribution can enhance the transmission and reception of ultrasonic energy, such as ultrasonic waves. A cMUT membrane having a non-uniform mass distribution and a plurality of electrodes corresponding with vibration modes of a cMUT membrane can enhance the transmission and reception of ultrasonic energy, such as ultrasonic waves at desired, but separate, frequency ranges during transmission and reception. In addition, a cMUT having an enhanced membrane according to the present invention can utilize a fundamental operating frequency of a cMUT membrane and harmonic frequencies of the fundamental operating frequency to transmit and receive ultrasonic signals.

Exemplary equipment for fabricating cMUTs according to the present invention can include, but are not limited to, a PECVD system, a dry etching system, a metal sputtering system, a wet bench, and photolithography equipment. cMUTs fabricated according to the present invention generally include materials deposited and patterned on a substrate in a build-up process. The present invention can utilize low-temperature PECVD processes for depositing various silicon nitride layers at approximately 250 degrees Celsius, which is preferably the maximum process temperature when a metal sacrificial layer is used. Alternatively, the present invention according to other preferred embodiments can utilize an amorphous silicon sacrificial layer deposited as a sacrificial layer at approximately 300 degrees Celsius.

Referring now the drawings, in which like numerals represent like elements, preferred embodiments of the present invention are herein described.

FIG. 1 illustrates a cross-sectional view of a harmonic cMUT 100 in accordance with a preferred embodiment of the present invention. The cMUT 100 generally comprises various components proximate a substrate 105. These components can comprise a substrate 105, a bottom electrode 110, a cavity 150, a membrane 115, a first top electrode element 130A, a second top electrode element 130B, and a third top electrode element 130C. The cMUT 100 can also comprise mass loads 155, 160, which will be understood shown exaggerated in the figures, and not to scale. The mass loads 155, 160 can be proximate, disposed on, or positioned along the membrane 115, and can be separate from, or integral with, the membrane 115. As will be discussed in further detail below with reference to FIGS. 5 and 6, a plurality of cMUTs 100 can be used in a cMUT imaging array.

The substrate **105** can be formed of silicon and can contain signal generation and reception circuits. The substrate **105** can also comprise materials enabling optical detection methods to be utilized, preferably transparent. The substrate **105** can comprise an integrated circuit **165** at least partially embedded in the substrate **105** to enable the cMUT **100** to transmit and receive ultrasonic energy or acoustical waves. In alternative embodiments the integrated circuit **165** can be located on another substrate (not shown) proximate the substrate **105**.

The integrated circuit **165** can be adapted to generate and receive electrical and optical signals. The integrated circuit **165** can also be adapted to provide signals to an image processor **170**. For example, the integrated circuit **165** can be coupled to the image processor **170**. The integrated circuit **165** can contain both signal generation and reception circuitry or separate integrated generation and reception circuits can be utilized. The image processor **170** can be adapted to process signals received or sensed by the integrated circuit **165** and create an image from electrical and optical signals.

The bottom electrode **110** can be deposited and patterned onto the substrate **105**. In an alternative embodiment, an adhesive layer (not shown) can be disposed between the substrate **105** and the bottom electrode **110**. An adhesion layer can be used to sufficiently bond the bottom electrode **110** to the substrate **105**. The adhesion layer can be formed of Chromium, or many other materials capable of bonding the bottom electrode **110** to the substrate **105**. The bottom electrode **110** is preferably fabricated from a conductive material, such as Gold or Aluminum. The bottom electrode **110** can also be patterned into multiple, separate electrode elements (not shown). Multiple electrode elements of the bottom electrode **110** can be similar to the top electrode elements **130A**, **130B**, **130C**. The multiple elements of the bottom electrode **110** can be isolated from each other with an isolation layer deposited on the multiple elements of the bottom electrode **110**, although upon later fabrication, some of the electrode elements can be electrically coupled. An isolation layer can also be utilized to protect the bottom electrode **110** from other materials used to form the cMUT **100**.

The membrane **115** preferably has elastic characteristics enabling it to fluctuate relative to the substrate **105**. In a preferred embodiment, the membrane **115** comprises silicon nitride and is formed from multiple membrane layers. For example, the membrane **115** can be formed from a first membrane layer and a second membrane layer. In addition, the membrane **130** can have side areas **116**, **117**, and a center area **118**. As shown, the center area **118** can be generally located equally between the side areas **116**, **117**.

The membrane **115** can also define a cavity **150**. The cavity **150** can be generally disposed between the bottom electrode **110** and the membrane **115**. The cavity **150** can be formed by removing or etching a sacrificial layer generally disposed between the bottom electrode **110** and the membrane **115**. In embodiments using an isolation layer, the cavity would be generally disposed between the isolation layer and the membrane **115**. The cavity **150** provides a chamber enabling the membrane **115** to fluctuate in response to stimuli, such as external pressure or electrostatic forces.

In a preferred embodiment, the membrane **115** comprises multiple electrode elements **130A**, **130B**, **130C** disposed within the membrane **115**. Alternatively, a single electrode or electrode element can be disposed within the membrane **115**. Two or more of the multiple electrode elements **130A**, **130B**, **130C** can be electrically coupled forming an electrode element pair. Preferably, side electrode elements **130A**, **130C** are formed nearer the sides **116**, **117** of the membrane **115**, and

center electrode element **130B** is formed nearer the center area **118** of the membrane **115**. The electrode elements **130A**, **130B**, **130C** can be fabricated using a conductive material, such as Gold or Aluminum. The side electrode elements **130A** and **130C** can be electrically coupled, and isolated from the center electrode element **130B**, to form an electrode element pair. The electrode elements **130A**, **130B**, **130C** can be formed from the same conductive material and patterned to have predetermined locations and varying geometrical configurations within the membrane **115**. The side electrode element pair **130A**, **130C** can have a width less than the center electrode **130B**, and at least a portion of the pair **130A**, **130C** can be placed at approximately the same distance from the substrate **105** as the center electrode element **130B**. In alternative embodiments, additional electrode elements can be formed within the membrane **115** at varying distances from the substrate **105**.

The electrode elements **130A**, **130B**, **130C** can be adapted to transmit and receive ultrasonic energy, such as ultrasonic acoustical waves. The side electrode elements **130A**, **130C** can be provided with a first signal from a first voltage source **175** ( $V_1$ ) and the center electrode **130B** can be provided with a second signal from a second voltage source **180** ( $V_2$ ). The side electrode elements **130A**, **130C** can be electrically coupled so that voltage or signal supplied to one of the electrode elements **130A**, **130C** will be provided to the other of the electrode elements **130A**, **130C**. These signals can be voltages, such as DC bias voltages and AC signals.

The side electrode elements **130A**, **130C** can be adapted to shape the membrane **115** to form a relatively large gap for transmitting ultrasonic waves. It is desirable to use a gap size that during transmission allows for greater transmission pressure. Further, the side electrode elements **130A**, **130C** can be adapted to shape the membrane **115** to form a relatively small gap for receiving ultrasonic waves. It is desirable to use a reduced gap size for reception that allows for greater sensitivity of the cMUT **100**. Both the center electrode element **130B** and the side electrode element elements **130A**, **130C** can receive and transmit ultrasonic energy, such as ultrasonic waves.

The cMUT **100** can be optimized for transmitting and receiving ultrasonic energy by altering the shape of the membrane **115**. The electrode elements **130A**, **130B**, **130C** can be provided with varying bias voltages and signals from voltage sources **175**, **180** ( $V_1$ ,  $V_2$ ) to alter the shape of the membrane **115**. Additionally, by providing the various voltages and signals, the cMUT **100** can operate in two states: a transmission state and a reception state. For example, during a receiving state, the side electrode elements **130A**, **130C** can be provided a DC bias voltage from the first voltage source **175** ( $V_1$ ) to optimize the shape of the membrane **115** for receiving an acoustic ultrasonic wave.

In a preferred embodiment of the present invention, the membrane **115** has a non-uniform mass distribution along its length. The membrane **115** has a varying mass distribution across its length, which variation can be a result of one or more of the following: varying thickness, density, material composition, and other membrane characteristics along the length of the membrane.

In a preferred embodiment, mass loads **155**, **160** are deposited and patterned onto the membrane **115** providing the membrane **115** to have a non-uniform mass distribution. Alternatively, the membrane **115** can be patterned to have a non-uniform mass distribution such that certain points along the length of the membrane **115** have varying masses via thickness and/or density variations.

The mass loads **155**, **160** are preferably formed of dense, malleable materials, including, but not limited to, Gold. Many other dense, malleable materials can be used to form the mass loads **155**, **160**. Gold is desirable because it is a dense, soft material, and thus does not significantly interfere with mem-  
 5  
 10  
 15  
 20  
 25  
 30  
 35  
 40  
 45  
 50  
 55  
 60  
 65

brane vibration due to the membrane's stiffness. In a preferred embodiment of the present invention, the mass loads **155**, **160** have a thickness of approximately one micro-meter and have a width of approximately two micro-meters. The size and shape of the mass loads **155**, **160** can be modified to achieved desired results. The mass loads **155**, **160** can be proximate the sides **116**, **117**, respectively. More than two mass loads **155**, **160** can also be utilized in other embodiments. The mass loads **155**, **160** can be used to control or adjust the vibrations and fluctuations of the membrane **115**. For example, the mass loads **155**, **160** can be placed or positioned to correspond with peak vibration regions of a particular vibration mode of the membrane **115**.

The membrane **115**, due to its elastic characteristics, can vibrate at various frequencies and can also have multiple vibration modes. For example, the membrane **115** can have a first order vibration mode as well as other higher order vibration modes (e.g., second order, third order, etc.). Adjusting the vibration modes of the membrane **115** can result in improved cMUT **100** performance. For example, shifting the vibration modes of the membrane **115** to occur at the operational frequencies and harmonics of the operational frequencies utilized by the cMUT **100** enables the membrane **115** to resonate at these frequencies when used, resulting in efficient transmission and reception of ultrasonic energy. With a combination of signals applied to and received from the voltage sources **175**, **180**, the transmission of ultrasonic energy can be minimized at a predetermined frequency and the received signals can be maximized at that particular frequency. Modifying the mass distribution of the membrane **115** can aid in shifting vibration modes of the membrane **115** to desired locations in the frequency spectrum for the cMUT **100**. For example, the membrane **115** can be mass loaded such that it receives a predetermined frequency. The predetermined frequency can be a harmonic frequency, such as a first harmonic frequency, of a signal transmitted by the cMUT **100**.

FIG. 2 illustrates a sample pulse-echo frequency spectrum of a harmonic cMUT **100** in accordance with a preferred embodiment of the present invention. As shown, a frequency response **205** for the harmonic cMUT **100** has a first peak **210** and a second peak **220**. The first peak **210** can coincide with a transmit frequency range **215** substantially centered around an operational frequency ( $f_o$ ). The second peak **220** can coincide with a receive frequency range **225** substantially centered around a second harmonic frequency of the operational frequency ( $2*f_o$ ). The membrane **115** of the cMUT **100** can be adjusted so that the frequency of the first vibration order is centered around the operational frequency ( $f_o$ ) and the second vibration order is centered around the second harmonic frequency of the operational frequency ( $2*f_o$ ). Such a configuration enables the vibration modes of the membrane **115** to be harmonically related such that the peaks of the vibration modes correspond to the operational frequency and harmonics of the operational frequency.

The membrane **115** of the cMUT **100** can be enhanced to have a frequency response as shown in FIG. 2. The membrane can be adapted to transmit and receive ultrasonic energy at a desired operational frequency and the second harmonic of the operational frequency. The present invention can also be used to enhance a cMUT membrane to operate at multiple vibration modes corresponding to a cMUT membrane. For example, the membrane **115** could be adjusted by locating

mass loads in certain locations on the membrane **115** to aid in moving a third vibration mode of the membrane **115**. The third vibration mode of the membrane **115** could be moved or adjusted to correspond with a third harmonic frequency ( $3*f_o$ ) to improve transmitted and received signals at the third harmonic frequency range. In addition to shifting vibration modes to correspond with certain harmonic frequencies, broad bandwidths can be created around the harmonic frequencies by shifting the vibration modes, thus increasing the transmitted and receiving ranges of the membrane **115**.

FIG. 3 illustrates a fabrication process utilized to fabricate a harmonic cMUT in accordance with a preferred embodiment of the present invention. Typically, the fabrication process is a build-up process that involves depositing various layers of materials on a substrate, and patterning the various layers in predetermined configurations to fabricate a cMUT **100** on the substrate **105**.

In a preferred embodiment of the present invention, a photoresist such as Shipley S-1813 is used to lithographically define various layers of a cMUT. Such a photoresist material does not require the use of the conventional high temperatures for patterning vias and material layers. Alternatively, many other photoresist or lithographic materials can be used.

A first step in the present fabrication process provides a bottom electrode **110** on a substrate **105**. The substrate **105** can comprise dielectric materials, such as silicon, quartz, glass, or sapphire. In some embodiments, the substrate **105** contains integrated electronics, and the integrated electronics can be separated for transmitting and receiving signals. Alternatively, a second substrate (not shown) located proximate the substrate **105** containing suitable signal transmission and detection electronics can be used. A conductive material, such as conductive metals, can form the bottom electrode **110**. The bottom electrode **110** can also be formed by doping a silicon substrate **105** or by depositing and patterning a conductive material layer, such as metal, on the substrate **105**. Yet, with a doped silicon bottom electrode **110**, all non-moving parts of a top electrode can increase parasitic capacitance, thus degrading device performance and prohibiting optical detection techniques for most of the optical spectrum.

To overcome these disadvantages, a patterned bottom electrode **110** can be used. As shown in FIG. 3(a), the bottom electrode **110** can be patterned to have a different length than the substrate **105**. By patterning the bottom electrode **110**, device parasitic capacitance can be significantly reduced.

The bottom electrode **110** can be patterned into multiple electrode elements, and the multiple electrode elements can be located at varying distances from the substrate **105**. Aluminum, chromium, and gold are exemplary metals that can be used to form the bottom electrode **110**. In one preferred embodiment of the present invention, the bottom electrode **110** has a thickness of approximately 1500 Angstroms, and after deposition, can be patterned as a diffraction grating, or to have various lengths.

In a next step, an isolation layer **315** is deposited. The isolation layer **315** can isolate portions of or the entire bottom electrode **110** from other layers placed on the bottom electrode **110**. The isolation layer **315** can be silicon nitride, and preferably has a thickness of approximately 1500 Angstroms. A Unaxis 790 PECVD system can be used to deposit the isolation layer **315** at approximately 250 degrees Celsius in accordance with a preferred embodiment. The isolation layer **315** can aid in protecting the bottom electrode **110** or the substrate **105** from etchants used during cMUT fabrication. Once deposited onto the bottom electrode layer **110**, the

isolation layer **315** can be patterned to a predetermined thickness. In an alternative preferred embodiment, an isolation layer **315** is not utilized.

After the isolation layer **315** is deposited, a sacrificial layer **320** is deposited onto the isolation layer **315**. The sacrificial layer **320** is preferably only a temporary layer, and is etched away during fabrication to form a cavity **150** in the cMUT **100**. When an isolation layer **315** is not used, the sacrificial layer **320** can be deposited directly on the bottom electrode **110**. The sacrificial layer **320** is used to hold a space while additional layers are deposited during cMUT fabrication. The sacrificial layer **320** can be formed with amorphous silicon that can be deposited using a Unaxis 790 PECVD system at approximately 300 degrees Celsius and patterned with a reactive ion etch ("RIE"). Sputtered metal can also be used to form the sacrificial layer **320**. The sacrificial layer **320** can be patterned into different sections, various lengths, and different thicknesses to provide varying geometrical configurations for a resulting cavity or via.

A first membrane layer **325** is then deposited onto the sacrificial layer **320**, as shown in FIG. 3(b). For example, the first membrane layer **325** can be deposited using a Unaxis 790 PECVD system. The first membrane layer **325** can be a layer of silicon nitride or amorphous silicon, and can be patterned to have a thickness of approximately 6000 Angstroms. The thickness of the first membrane layer **325** can vary depending on the particular implementation. Depositing the first membrane layer **325** over the sacrificial layer **320** aids in forming a vibrating membrane **115**.

After patterning the first membrane layer **325**, a second conductive layer **330** can be deposited onto the first membrane layer **325** as illustrated in FIG. 3(c). The second conductive layer **330** can form the top electrode(s) of a cMUT. The second conductive layer **130** can be patterned into different electrode elements **130A**, **130B**, **130C** that can be isolated from each other. The electrodes **130A**, **130B**, **130C** can be placed at varying distances from the substrate **105**. One or more of the electrode elements **130A**, **130B**, **130C** can be electrically coupled forming an electrode element pair. For example, the side electrode elements **130A**, **130C** can be coupled together, forming an electrode element pair. Preferably, the formed electrode pair **130A**, **130C** is isolated from the center electrode element **130B**.

The electrode element pair **130A**, **130C** can be formed from conductive metals such as Aluminum, Chromium, Gold, or combinations thereof. In an exemplary embodiment, the electrode element pair **130A**, **130C** comprises Aluminum having a thickness of approximately 1200 Angstroms and Chromium having a thickness of approximately 300 Angstroms. Aluminum provides good electrical conductivity, and Chromium can aid in smoothing any oxidation formed on the Aluminum during deposition. Additionally, the electrode element pair **130A**, **130C** can comprise the same conductive material or a different conductive material than the first conductive layer **110**.

In a next step, a second membrane layer **335** is deposited over the electrode elements **130A**, **130B**, **130C** as illustrated in FIG. 3(d). The second membrane layer **335** increases the thickness of the cMUT membrane **115** at this point in fabrication (formed by the first and second membrane layers **325**, **335**), and can serve to protect the second conductive layer **330** from etchants used during cMUT fabrication. The second membrane layer **335** can also aid in isolating the first electrode element **130A** from the second electrode element **130B**. The second membrane layer can be approximately 6000 Angstroms thick. In some embodiments, the second membrane layer **335** is adjusted using deposition and patterning tech-

niques so that the second membrane layer **335** has an optimal geometrical configuration. Preferably, once the second membrane layer **335** is adjusted according to a predetermined geometric configuration, the sacrificial layer **320** is etched away, leaving a cavity **150** as shown in FIG. 3(f).

The first and second membrane layers **325**, **335** can form the membrane **115**. The membrane **115** can fluctuate or resonate in response to stimuli, such as external pressures and electrostatic forces. In addition, the membrane **115** can have multiple vibration modes due to its elastic characteristics. The location of these vibration modes can be helpful in designing and fabricating a cMUT according to the present invention. For example, the first and second conductive layers **310**, **330** can be patterned into electrodes or electrode elements proximate the vibration modes of the composite membrane. Such electrode and electrode element placement can enable efficient reception and transmission of ultrasonic energy. In addition, the location of vibration modes for the membrane **115** can be adjusted and controlled by changing the mass distribution of the membrane **115**.

To enable etchants to reach the sacrificial layer **320**, apertures **340**, **345** can be etched through the first and second membrane layers **325**, **335** using an RIE process. As shown in FIG. 3(e), access passages to the sacrificial layer **320** can be formed at apertures **340**, **345** by etching away the first and second membrane layers **325**, **335**. When an amorphous silicon sacrificial layer **320** is used, one must be aware of the selectivity of the etch process to silicon. If the etching process has low selectivity, one can easily etch through the sacrificial layer **320**, the isolation layer **315**, and down to the substrate **105**. If this occurs, the etchant can attack the substrate **305** and can destroy a cMUT device. When the bottom electrode **110** is formed from a metal that is resistant to the etchant used through the sacrificial layer, the metal layer can act as an etch retardant and protect the substrate **105**. Those skilled in the art will be familiar with various etchants and capable of matching the etchants to the materials being etched. After the sacrificial layer **320** is etched, the cavity **350** can be sealed with seals **342**, **347**, as shown in FIG. 5(f).

The cavity **350** can be formed between the isolation layer **315** and the membrane layers **325**, **335**. The cavity **350** can also be disposed between the bottom electrode **110** and the first membrane layer **325**. The cavity **350** can be formed to have a predetermined height in accordance with some preferred embodiments of the present invention. The cavity **350** enables the cMUT membrane **115**, formed by the first and second membrane layers **325**, **335**, to fluctuate and resonate in response to stimuli. After the cavity **350** is formed by etching the sacrificial layer **320**, the cavity **350** can be vacuum sealed by depositing a sealing layer (not shown) on the second membrane layer **335**. Those skilled in the art will be familiar with various methods for setting a pressure in the cavity **350** and then sealing it to form a vacuum seal.

The sealing layer is typically a layer of silicon nitride, having a thickness greater than the height of the cavity **350**. In an exemplary embodiment, the sealing layer has a thickness of approximately 4500 Angstroms, and the height of the cavity **350** is approximately 1500 Angstroms. In alternative embodiments, the second membrane layer **335** is sealed using a local sealing technique or sealed under predetermined pressurized conditions. Sealing the second membrane layer **335** can adapt the cMUT for immersion applications. After depositing the sealing layer, the thickness of the cMUT membrane **115** can be adjusted by etching back the sealing layer since the cMUT membrane **115** may be too thick to resonate at a desired frequency. A dry etching process, such as RIE, can be used to etch the sealing layer.

In a next step, the non-uniform mass distribution of the membrane of the cMUT can be accomplished by depositing multiple mass loads **155**, **160** onto the second membrane layer **335**. Multiple mass loads **155**, **160** can be placed at various places on the second membrane layer **335**. The location of the multiple mass loads **155**, **160** on the second membrane layer **335** can correspond to vibration modes of the membrane **115** formed by the first and second membrane layers **325**, **335**. The multiple mass loads **155**, **160** can also be used to shift or adjust the vibration modes of the membrane formed by the first and second membrane layers **325**, **335** to certain predetermined areas. This feature of the present invention enables a specific vibration mode of interest to be selectively controlled. These predetermined areas can be located near the electrode elements **130A**, **130B**, **130C** so that the electrode elements **130A**, **130B**, **130C** can be used to transmit and receive ultrasonic acoustical waves. In an alternative embodiment, the second membrane layer **335** can be patterned to have regions of different thickness to form a membrane having a non-uniform mass distribution.

A final step in the present cMUT fabrication process prepares the cMUT for electrical connectivity. Specifically, RIE etching can be used to etch through the isolation layer **315** on the bottom electrode **110**, and the second membrane layer **335** on the electrode elements **130A**, **130B**, **130C** making them accessible for connections.

Additional bond pads can be formed and connected to the electrodes. Bond pads enable external electrical connections to be made to the top and bottom electrodes **110**, **130** with wire bonding. In some embodiments, gold can be deposited and patterned on the bond pads to improve the reliability of the wire bonds.

In an alternative embodiment of the present invention, the sacrificial layer **320** can be etched after depositing the first membrane layer **325**. This alternative embodiment invests little time in the cMUT **100** before performing the step of etching the sacrificial layer **320** and releasing the membrane **115** formed by the membrane layers **325**, **335**. Since the top electrode **130** has not yet been deposited, there is no risk that pinholes in the second membrane layer **335** could allow the top electrode **330** to be destroyed by etchants.

FIG. 4 illustrates a logical flow diagram depicting a preferred method to fabricate a harmonic cMUT **100** in accordance with a preferred embodiment of the present invention. The first step involves providing a substrate **105** (**405**). The substrate **105** can be of various constructions, including opaque, translucent, or transparent. For example, the substrate **150** can be, but is not limited to, silicon, glass, or sapphire. Next, an isolation layer can be deposited onto the substrate **105**, and patterned to have a predetermined thickness (**410**). The isolation layer is optional, and may not be utilized in some embodiments. An adhesive layer can also be used in some embodiments ensuring that an isolation layer bonds to a substrate **105**, or the bottom electrode **110** can adequately bond to the substrate **105**.

After the isolation layer is patterned, a first conductive layer **110** is deposited onto the isolation layer, and patterned into a predetermined configuration (**415**). Alternatively, a doped surface of a substrate **105**, such as a doped silicon substrate surface, can form the first conductive layer **110**. The first conductive layer **110** preferably forms a bottom electrode **110** for a cMUT **100** on a substrate **105**. The first conductive layer **110** can be patterned to form multiple electrode elements. At least two of the multiple electrode elements can be coupled together to form an electrode element pair.

Once the first conductive layer **110** is patterned into a predetermined configuration, a sacrificial layer **320** is depos-

ited onto the first conductive layer **110** (**420**). The sacrificial layer **320** can be patterned by selective deposition and patterning techniques so that it has a predetermined thickness. Then, a first membrane layer **325** can be deposited onto the sacrificial layer **320** (**425**).

The deposited first membrane layer **325** is then patterned to have a predetermined thickness, and a second conductive layer **130** is then deposited onto the first membrane layer **325** (**430**). The second conductive layer **130** preferably forms a top electrode **130** for a cMUT **100**. The second conductive layer **130** can be patterned to form multiple electrode elements **130A**, **130B**, **130C**. At least two of the multiple electrode elements **130A**, **130B**, **130C** can be coupled together to form an electrode element pair. After the second conductive layer **130** is patterned into a predetermined configuration, a second membrane layer **335** is deposited onto the patterned second conductive layer **130** (**435**). The second membrane layer **335** can also be patterned to have an optimal geometric configuration.

The first and second membrane layers **325**, **335** can encapsulate the second conductive layer **130**, enabling it to move relative to the first conductive layer **110** due to elastic characteristics of the first and second membrane layers **325**, **335**. After the second membrane layer **335** is patterned, the sacrificial layer **320** is etched away, forming a cavity **150** between the first and second conductive layers **110**, **130** (**435**). The cavity **150** formed below the first and second membrane layers **325**, **335** provides space for the resonating first and second membrane layers **325**, **335** to move relative to the substrate **105**. In a next step, the second membrane layer **335** is sealed by depositing a sealing layer onto the second membrane layer **335** (**435**).

In a final step (**440**), a mass load can be formed on the second membrane layer **335**. Multiple mass loads can also be formed on the second membrane layer **335**, and they can be placed at point on the second membrane layer **335** corresponding to vibration modes of a membrane **115** formed by the first and second membrane layers **325**, **335**. The mass loads are preferably formed of dense, malleable materials, such as Gold. The mass loads can aid in changing the mass distribution of the membrane layer **115** so that the membrane layer **115** has regions of varying thickness. In an alternative embodiment, the membrane layer **115** can be patterned to have regions of varying thickness or densities.

The embodiments of the present invention can also be utilized to form a cMUT array for a cMUT imaging system. Those skilled in the art will recognize that the cMUT imaging arrays illustrated in FIGS. 5 and 6 are only exemplary, and that other imaging arrays are achievable in accordance with the embodiments of the present invention.

FIG. 5 illustrates a cMUT imaging array device formed in a ring-annular array on a substrate. As shown, the device **500** includes a substrate **505** and cMUT arrays **510**, **515**. The substrate **505** is preferably disc-shaped, and the device **500** may be utilized as a forward looking cMUT imaging array. Although the device **500** is illustrated with two cMUT arrays **510**, **515**, other embodiments can have one or more cMUT arrays. If one cMUT array is utilized, it can be placed near the outer periphery of the substrate **505**. If multiple cMUT arrays are utilized, they can be formed concentrically so that the circular-shaped cMUT arrays have a common center point. Some embodiments can also utilize cMUT arrays having different geometrical configurations in accordance with some embodiments of the present invention.

FIG. 6 illustrates a cMUT imaging array system formed in a side-looking array on a substrate. As shown, the device **600** includes a substrate **605**, and cMUT arrays **610**, **615**. The

substrate **605** can be cylindrically-shaped, and the cMUT arrays can be coupled to the outer surface of the substrate **605**. The cMUT arrays **610**, **615** can comprise cMUT devices arranged in an interdigital fashion and used for a side-looking cMUT imaging array. Some embodiments of device **600** can include one or multiple cMUT imaging arrays **610**, **615** in spaced apart relation on the outer surface of the cylindrically-shaped substrate **600**.

The present invention also contemplates analyzing a cMUT **100** or cMUT array to determine the location of the vibration modes of a cMUT membrane and to determine the position of mass loads to adjust the vibration modes of a cMUT membrane. For convenience, the components of the cMUT discussed below are with reference to FIG. 7. The description of particular functions of the components, or specific arrangement and sizes of the components, however, are not intended to limit the scope of FIG. 7 and are provided only for example, and not limitation.

An approach to analyze a cMUT is to simulate the motion of a cMUT membrane in a fluid, such as water. For example, a finite element analysis tool, such as the ANSYS™ tool, can be used to simulate the motion of a cMUT membrane. In a preferred embodiment of the present invention, the membrane can have a width of approximately 40 μm and a thickness of approximately 0.6 μm. Alternatively, other dimensions can be used. Since the membrane can be long and rectangular, 1-D analysis can be used. Other simulations can use other dimensional analysis parameters, such as 2-D or 3-D.

To simulate electrostatic actuation of the cMUT a uniform pressure of 1 kPa (kilo-Pascal) can be applied to the membrane. A resulting vibration profile of the membrane can then be calculated. FIG. 7 shows an average velocity **700** over the membrane as a function of frequency. As can be seen, the spectrum **705** is relatively flat in the 2-30 MHz range with the exception of nulls **710**, **715** at approximately 8 MHz and approximately 24 MHz. To further understand the vibration profile of the membrane, the maximum velocity over the membrane can be calculated and plotted, as illustrated in FIG. 8. As shown in FIG. 8, the velocity of the membrane can have five peaks **805A**, **805B**, **805C**, **805D**, **805E**. The local peak velocities of the membrane can be more than an order of magnitude larger than the average velocity.

When the membrane displacement profile is plotted around the frequencies where the peaks occur, the nulls in the average velocity occur at frequencies where the membrane moves close to its third and fifth resonances. FIGS. 9A-C illustrate the vibration profiles over the membrane at 0.8 MHz and 8 MHz. These frequencies correspond to the first and third vibration modes of the membrane. Although the cMUT does not generate any considerable pressure output around 8 MHz, the membrane locally vibrates with large amplitude in response to an applied pressure. Therefore, by placing localized electrodes over the parts of the membrane where a particular mode has peak velocity, large output signals can be generated around a certain frequency range. Furthermore, by selectively displacing the location of the particular vibration mode one can determine where the enhanced response would occur.

The present invention also contemplates utilizing the higher order vibration modes for cMUT design by selectively controlling the frequency of a particular membrane vibration mode of interest. For example, this can be accomplished by disposing mass loads on the membrane at predetermined locations. The mass distribution of a membrane can be altered by depositing and patterning mass loads on a uniform membrane, resulting in a membrane with a non-uniform mass

distribution. The third vibration mode, for example, is targeted and the mass loads are concentrated on the regions of the membrane having peak strain energy (i.e. peaks).

The mass loads are preferably Gold due to its high density and low stiffness. The Gold can be configured to have a thickness of approximately one micro-meter and a width of approximately two micro-meters. The mass loads can be positioned at the peak displacement locations **1015**, **1020** as shown in FIG. 10A-B. As shown in FIGS. 10A-B, by positioning the mass loads at peak displacement locations **1015**, **1020** the third vibration mode frequency can be shifted from approximately 8 MHz (see **1105**) to approximately 6.5 Mhz (see **1110**). The shifting of a third vibration mode frequency for the membrane can occur without significantly affecting the surrounding vibration modes of the membrane, such as the second and fourth vibration modes.

As an example of the mass loading approach discussed above, the membrane can be designed to reduce a null occurring at approximately 8 MHz in a cMUT spectrum, as shown in FIG. 11. The membrane can be loaded with different mass loads positioned to correspond with a third vibration mode. The membrane can have a width and thickness of approximately one micro-meter, and the mass loads can have a thickness of approximately one micro-meter and a width of approximately two micro-meters. As shown in FIG. 11, positioning the mass loads along the membrane adjusts the average velocity of the membrane.

FIG. 11 shows a reduction on the null **1110** occurring at approximately 8 MHz. Thus, by enhancing the shape of the membrane, the frequency response of the membrane can be optimized. As further illustrated by FIG. 11, the mass loading does not greatly affect the average velocity of the membrane for most of the spectrum, which evinces that the mass loading of the membrane does not reduce the overall efficiency of the cMUT. The resulting frequency spectrum of the cMUT can be further shaped by continuously positioning additional mass loads along the membrane.

A preferred application utilizing cMUTs with high order vibration mode control as contemplated by the present invention is harmonic imaging. Since mass loads can be used to change the location of peaks in a cMUT's frequency spectrum, signals received at desired frequency ranges can be improved. In addition, by patterning cMUT electrodes into multiple elements, as discussed above, vibrations local to the multiple elements can be selectively detected. For example, a cMUT having a dual electrode element structure having side electrode elements with a width of approximately 10 micrometers and a center electrode element of approximately 15 micrometers can be used to selectively detect vibrations occurring at different vibration modes.

FIG. 12 shows an estimated transmit and receive spectra of a harmonic cMUT. Both center and side electrode elements can be used in transmitting ultrasonic energy, and only side electrode elements can be used to receive ultrasonic energy. As FIG. 12 illustrates, a harmonic cMUT can have a wide-band transmit spectrum **1300** suitable for transmitting a fundamental frequency of approximately 4 MHz. In addition, the spectrum of the received signal **1310**, which shows that the harmonic signals around 8 MHz, is amplified relative to the transmitted spectrum by nearly 15 dB. Since harmonic signals are subject to more attenuation, the present invention provides improved cMUT design with enhanced receive and transmit frequency spectrums.

While the various embodiments of this invention have been described in detail with particular reference to exemplary embodiments, those skilled in the art will understand that variations and modifications can be effected within the scope

17

of the invention as defined in the appended claims. Accordingly, the scope of the various embodiments of the present invention should not be limited to the above discussed embodiments, and should only be defined by the following claims and all applicable equivalents.

I claim:

1. In a forward or side looking catheter device having a plurality of cMUT arrays for transmitting and receiving ultrasonic energy, the forward looking intravascular device comprising:

a plurality of cMUT arrays being disposed on a substrate in a spaced apart arrangement so that the cMUT arrays are disposed at differing locations,

the plurality of cMUT arrays each comprising a plurality of cMUT elements, wherein at least some of the plurality of cMUT elements comprise a flexible membrane disposed above the membrane and a membrane frequency adjustor for adjusting a vibration mode of the membrane.

2. The forward or side looking device of claim 1, wherein the cMUT arrays are arranged as concentric annular rings on the surface of the substrate.

3. The forward or side looking device of claim 1, wherein the substrate is disc-shaped and the plurality of cMUT arrays are disposed on the surface of the disc-shaped surface.

4. The forward or side looking device of claim 1, wherein the plurality of cMUT arrays comprises a first cMUT array and a second cMUT array, the first cMUT array being disposed proximate the outer periphery of the substrate, and the second cMUT array being in a position different than the first cMUT array.

5. The forward or side looking device of claim 1, wherein the plurality of cMUT elements further comprise one or more electrode elements configured to receive ultrasonic signals for transmission and to receive bias voltages for positioning the membrane for transmission and reception of ultrasonic waves.

6. The forward or side looking device of claim 1, wherein the plurality of cMUT arrays are distributed at different positions on the substrate.

7. The forward or side looking device of claim 1, wherein a portion of the cMUT elements comprise a plurality of mass loads as the frequency membrane adjustor, the mass loads being disposed proximate the membrane.

18

8. The forward or side looking device of claim 1, wherein the membrane frequency adjustor is an electrode element enveloped in the membrane.

9. The forward or side looking device of claim 1, wherein the membrane and the membrane frequency adjustor are formed from the same material.

10. The forward or side looking device of claim 1, wherein a portion of the cMUT elements are configured to transmit and receive ultrasonic at differing frequencies so that the cMUT arrays are configured to transmit and receive ultrasonic at differing frequencies.

11. A cMUT-based device configured as a forward or side looking intravascular ultrasonic array device that comprises a plurality of cMUT devices, the forward or side looking ultrasonic array device comprising:

a plurality of cMUT devices formed in a plurality of array portions, the array portions being disposed at differing locations of a substrate that carries the cMUT devices; and

at least a portion of the cMUT devices comprising a membrane that defines a cavity situated between the membrane and the substrate, and wherein a mass load is disposed proximate the membrane, the mass load being configured to adapt the membrane to receive energy at a predetermined frequency.

12. The forward or side looking ultrasonic array device of claim 11, wherein the cMUT devices are configured to transmit and receive ultrasonic waves at separate frequency ranges.

13. The forward or side looking ultrasonic array device of claim 11, further comprising integrated electronics associated with the array portions to enable cMUT devices within the array portion to transmit and receive ultrasonic energy.

14. The forward or side looking ultrasonic array device of claim 11, wherein at least a portion of the cMUT devices comprise electrodes configured to enable the array portions to transmit and receive ultrasonic energy at differing frequencies.

15. The forward or side looking ultrasonic array device of claim 14, wherein the electrodes are configured as multiple element electrodes to enable the cMUT devices to transmit and receive ultrasonic energy.

\* \* \* \* \*