

[54] AUTOMATIC TRAFFIC CONTROL SYSTEM

[75] Inventor: Ernest Timmons Hungerford, Atlanta, Ga.

[73] Assignee: Georgia Tech Research Institute, Atlanta, Ga.

[22] Filed: June 29, 1971

[21] Appl. No.: 157,871

[52] U.S. Cl. 340/35, 340/41 R

[51] Int. Cl. G08g 1/08

[58] Field of Search 340/35, 37, 40, 41

[56] References Cited

UNITED STATES PATENTS

3,090,032	5/1963	Shand et al.	340/41
3,119,093	1/1964	Wilyard	340/40
3,159,817	12/1964	Hendricks et al.	340/41
3,175,183	3/1965	Wilyard	340/41
3,241,104	3/1966	DuVivier	340/35
3,247,482	4/1966	Leshner	340/41
3,254,324	5/1966	Casciato et al.	340/35
3,268,814	8/1966	DuVivier	340/40
3,302,170	1/1967	Jensen et al.	340/40
3,305,828	2/1967	Auer, Jr. et al.	340/40
3,328,791	6/1967	Casciato	340/35
3,423,733	1/1969	Auer, Jr. et al.	340/41
3,482,208	12/1969	Auer, Jr. et al.	340/35
3,503,040	3/1970	Hendricks	340/35
3,506,808	4/1970	Riddle, Jr. et al.	340/35
3,594,719	7/1971	Endo et al.	340/40
3,605,084	9/1971	Matysek	340/40
3,675,196	7/1972	Molloy et al.	340/35

OTHER PUBLICATIONS

"Computer-Controlled Vehicular Traffic," Gordon D. Friedlander, IEEE Spectrum, February 1969, pages 30-43.

IBM Technical Disclosure Bulletin, M. Drucker, Vol. 7, No. 3, August 1964, pages 211 & 212.

Primary Examiner—Kathleen H. Claffy
Assistant Examiner—Randall P. Myers
Attorney, Agent, or Firm—Newton, Hopkins & Ormsby

[57] ABSTRACT

An automated control system is disclosed that is particularly adapted for use in regulating urban traffic flow. The system includes a central control facility linked with a plurality of remote terminals over a unitary communication channel, which is preferably equivalent to a voice grade, non-compensated telephone line. The central control facility includes a computer coupled through interface equipment with a master transceiver. The master transceiver couples the computer and interface equipment with the communication channel. Each of the remote terminals, which are coupled to the communication channel in parallel, party line fashion, includes a remote transceiver coupled through interface equipment to a traffic control device, such as a signal light. An emergency vehicle locator may also be included in each remote terminal. Vehicle detectors may be coupled to the communication channel through the remote terminals or through separate remote transceivers to provide a measure of traffic flow parameters.

33 Claims, 18 Drawing Figures

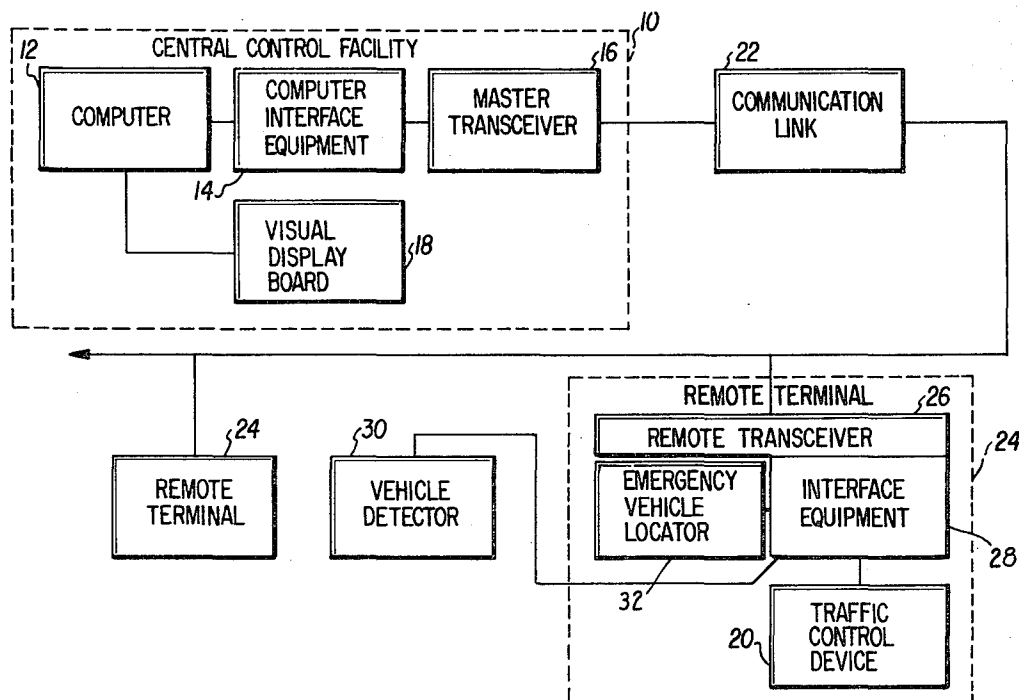

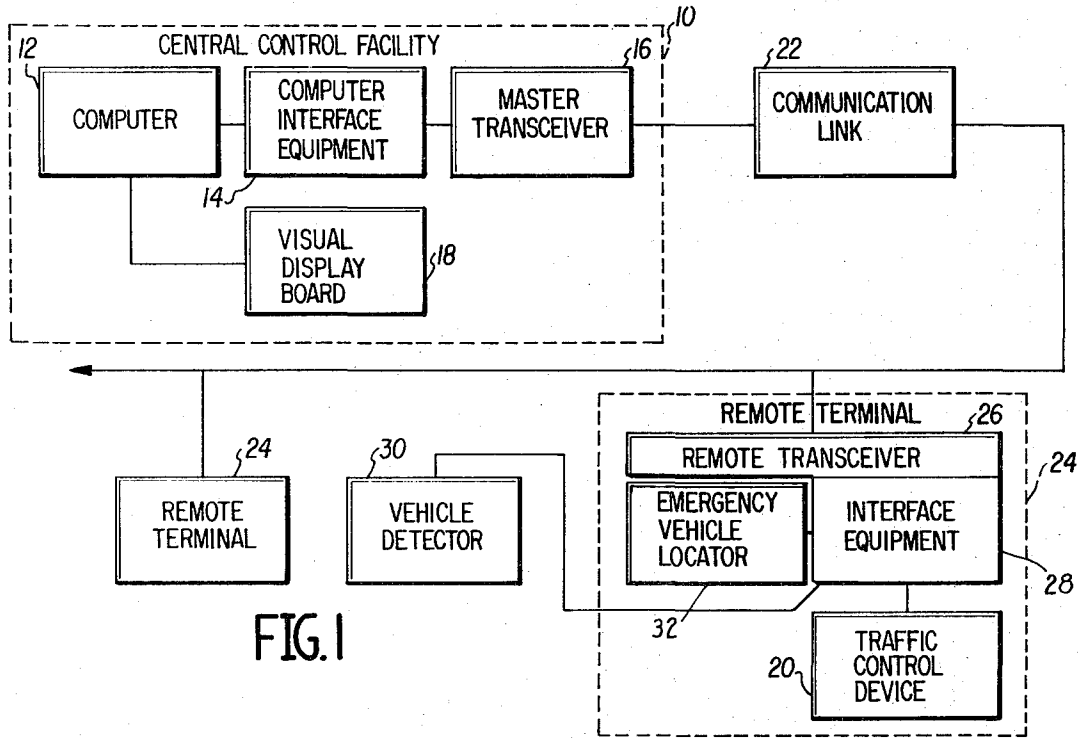

FIG. 1

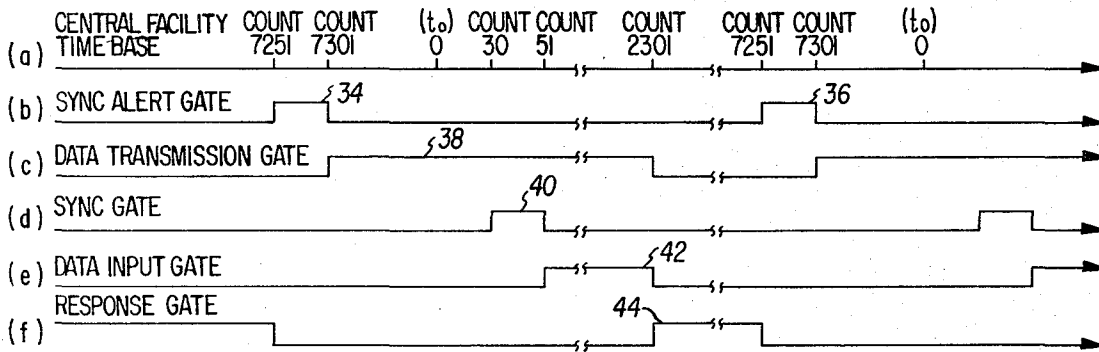

FIG. 2 MASTER TRANSCEIVER TIMING DIAGRAM

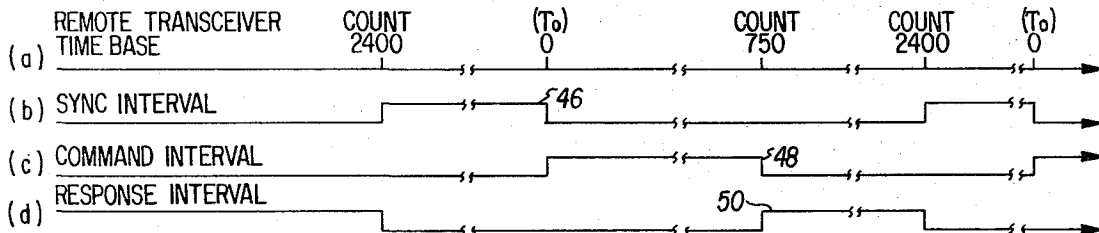

FIG. 3 REMOTE TRANSCEIVER TIMING DIAGRAM

INVENTOR
ERNEST T. HUNGERFORD

BY *Newton, Hopkins, & Ormsby*
ATTORNEYS

FIG. 4

MASTER TRANSCIVER MODULATOR AND RESPONSE RECEIVER SECTIONS

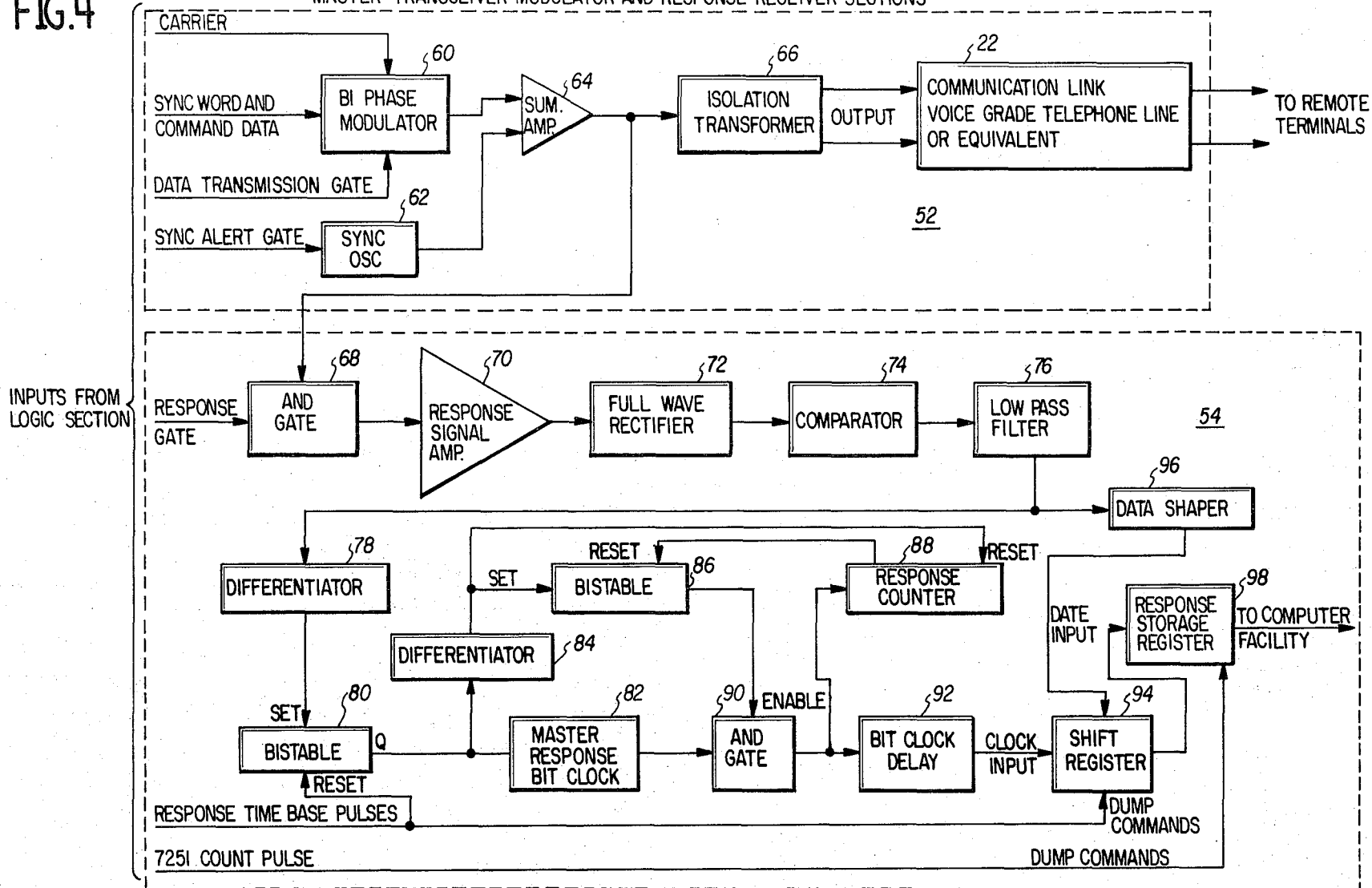

PATENTED AUG 6 1974

SHEET 02 OF 14

3,828,307

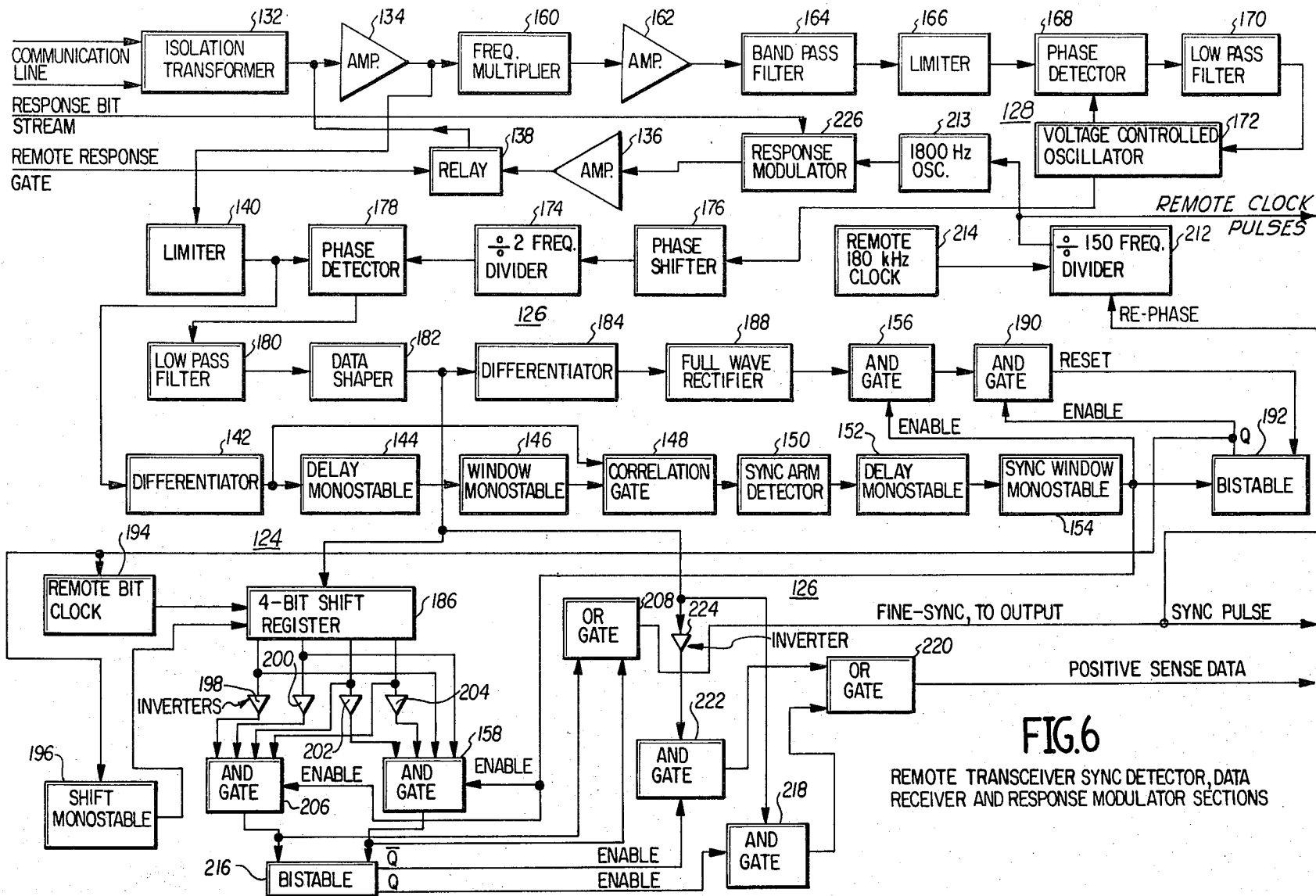

FIG. 6
 REMOTE TRANSCIVER SYNC DETECTOR, DATA
 RECEIVER AND RESPONSE MODULATOR SECTIONS

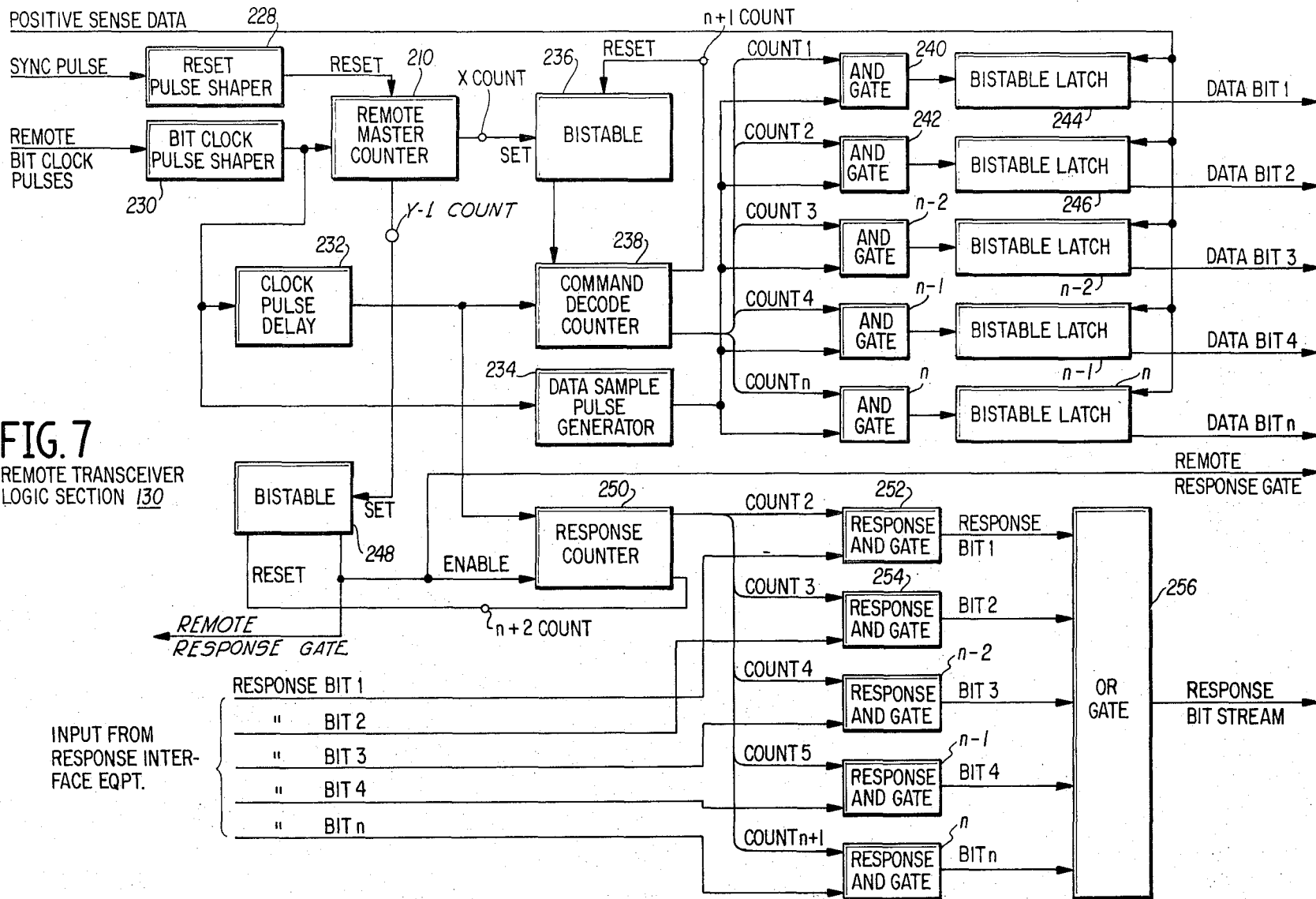

FIG. 7
 REMOTE TRANSCIVER
 LOGIC SECTION 130

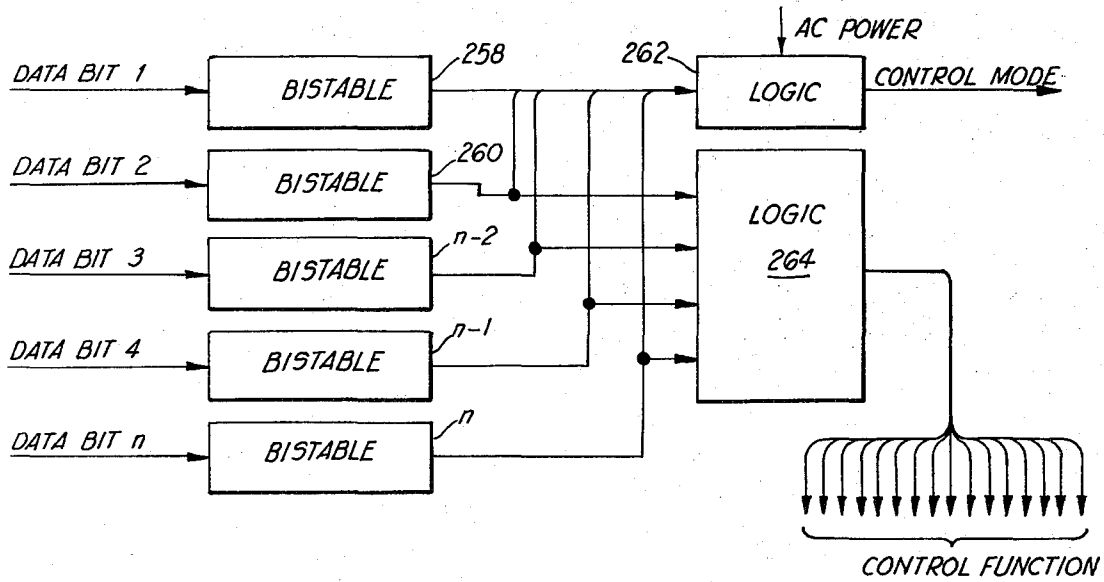

FIG. 8

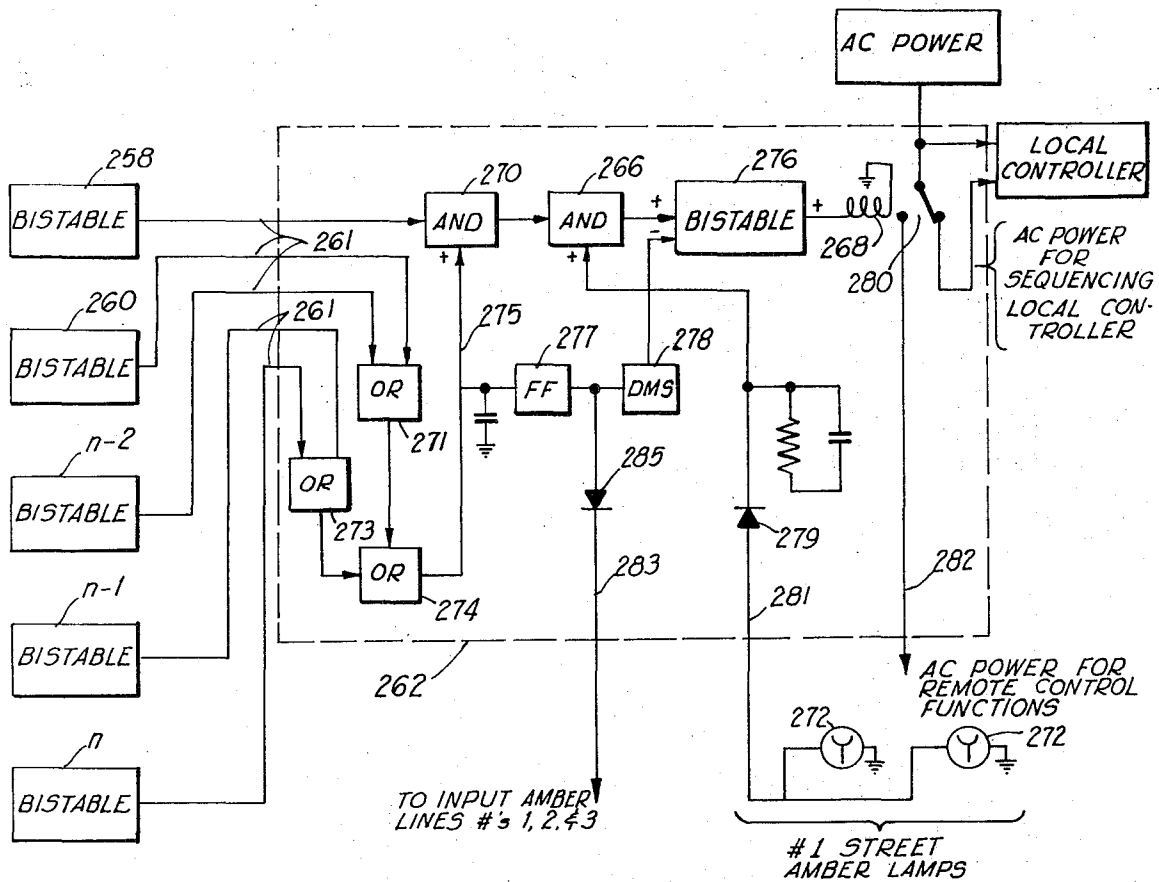

FIG. 9

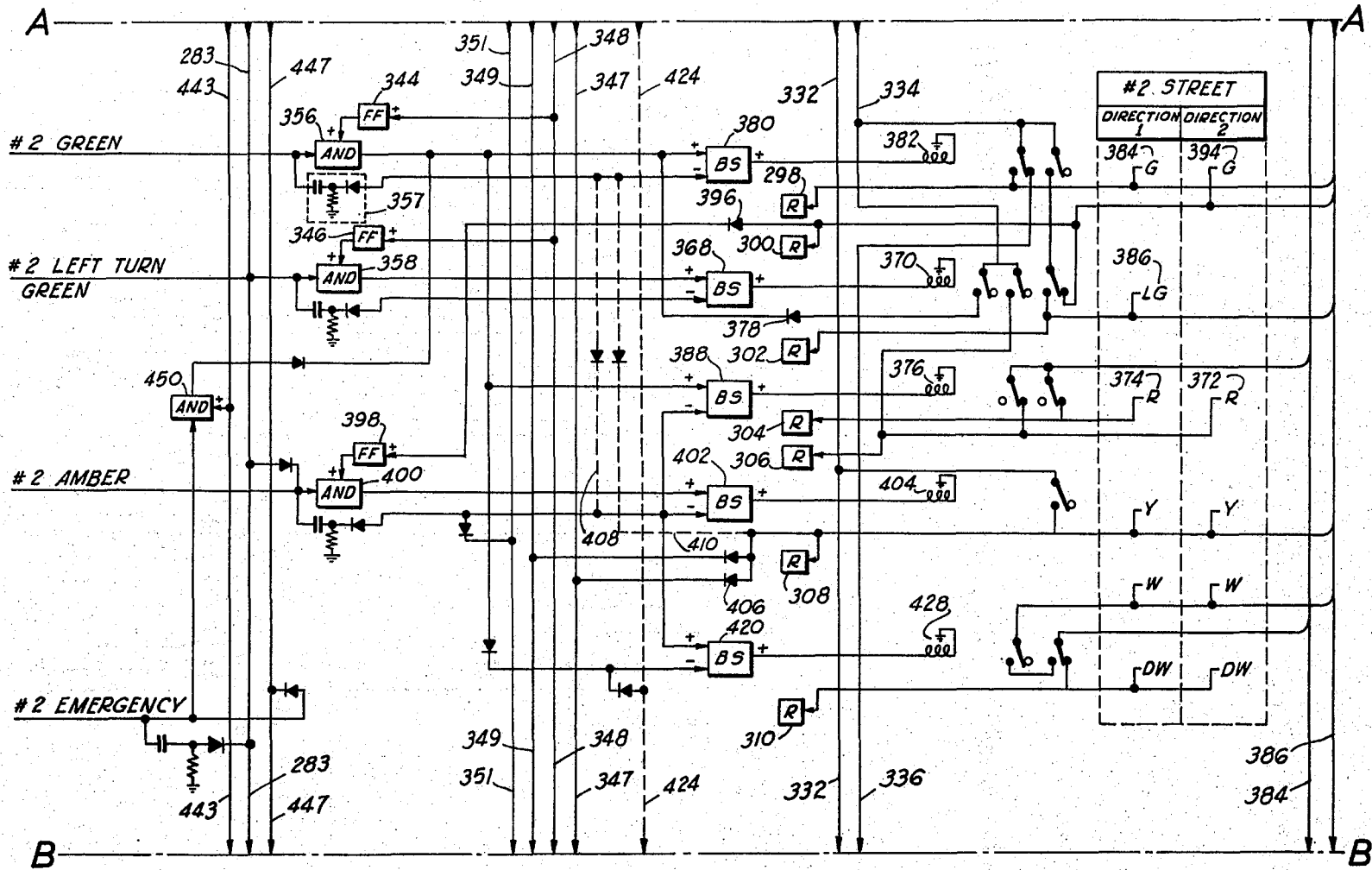

FIG. 10B

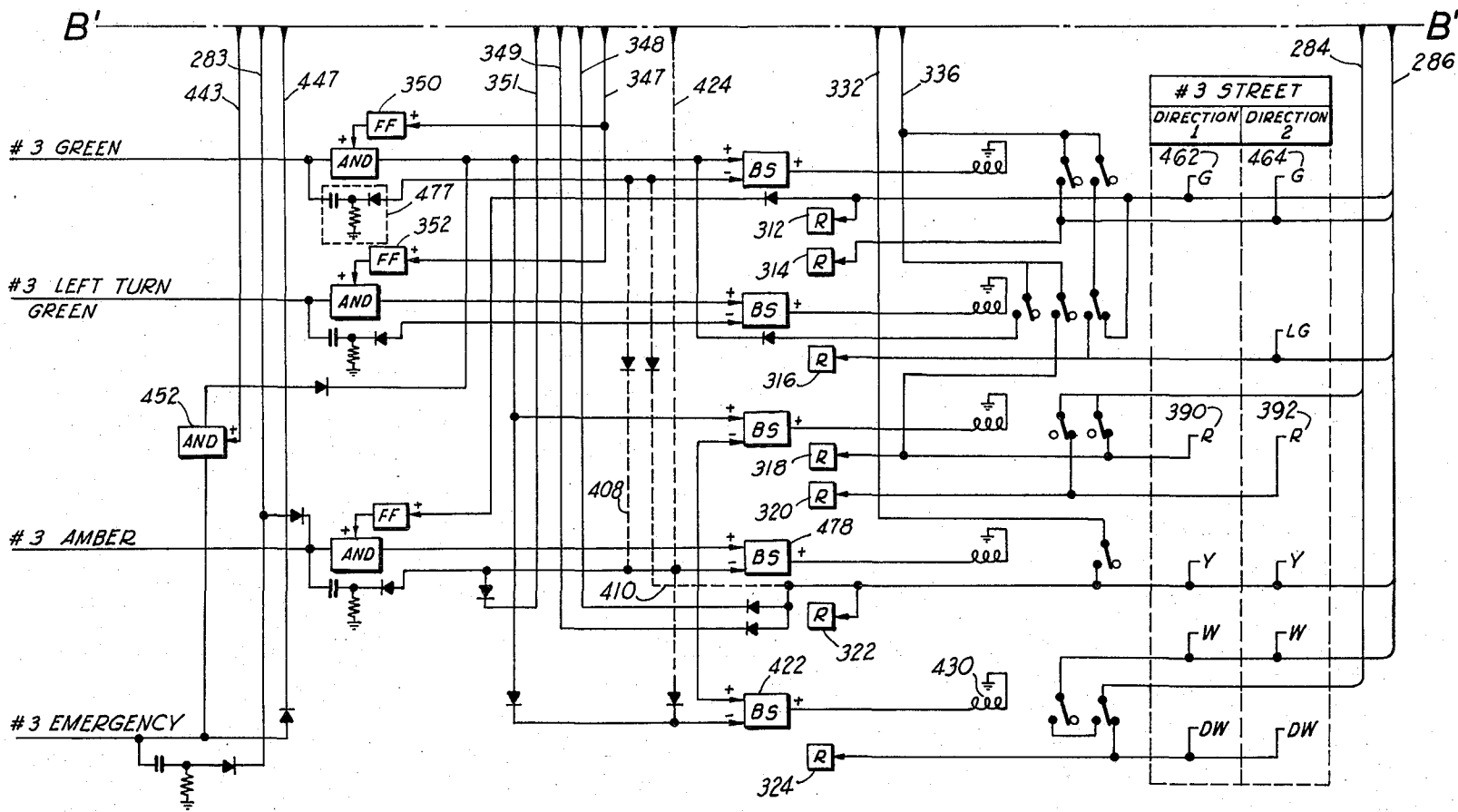
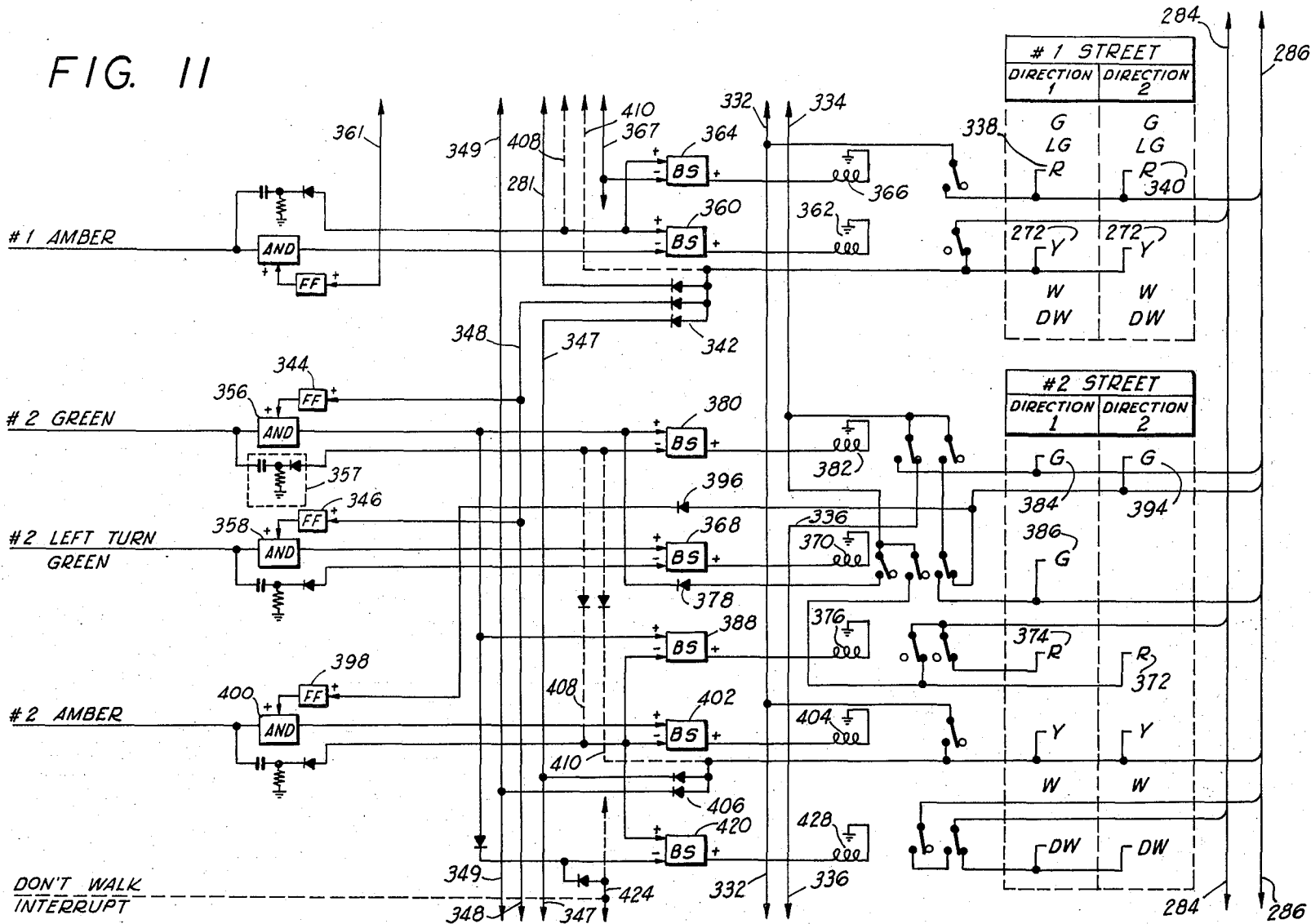

FIG. 10C

FIG. II



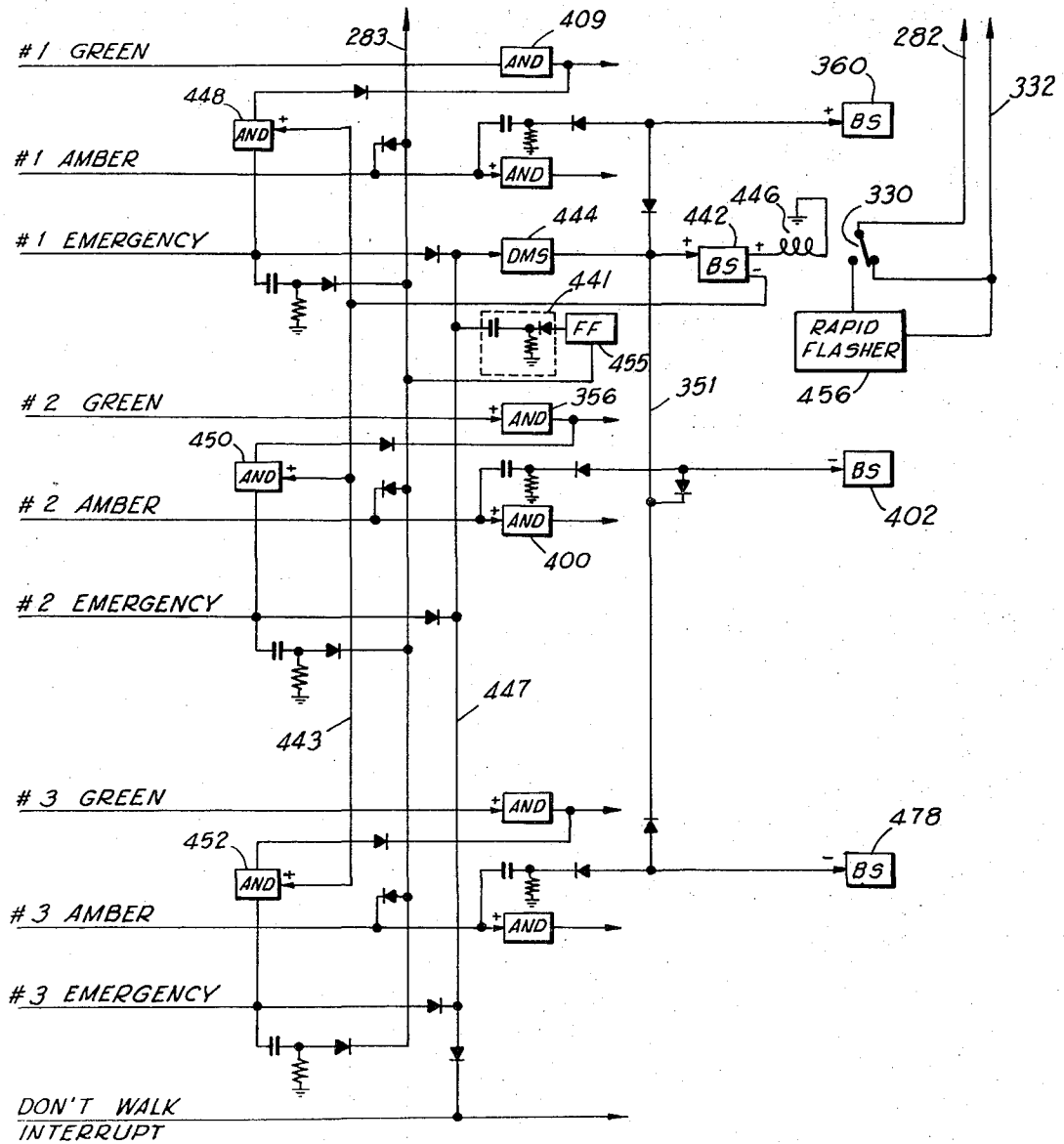

FIG. 12

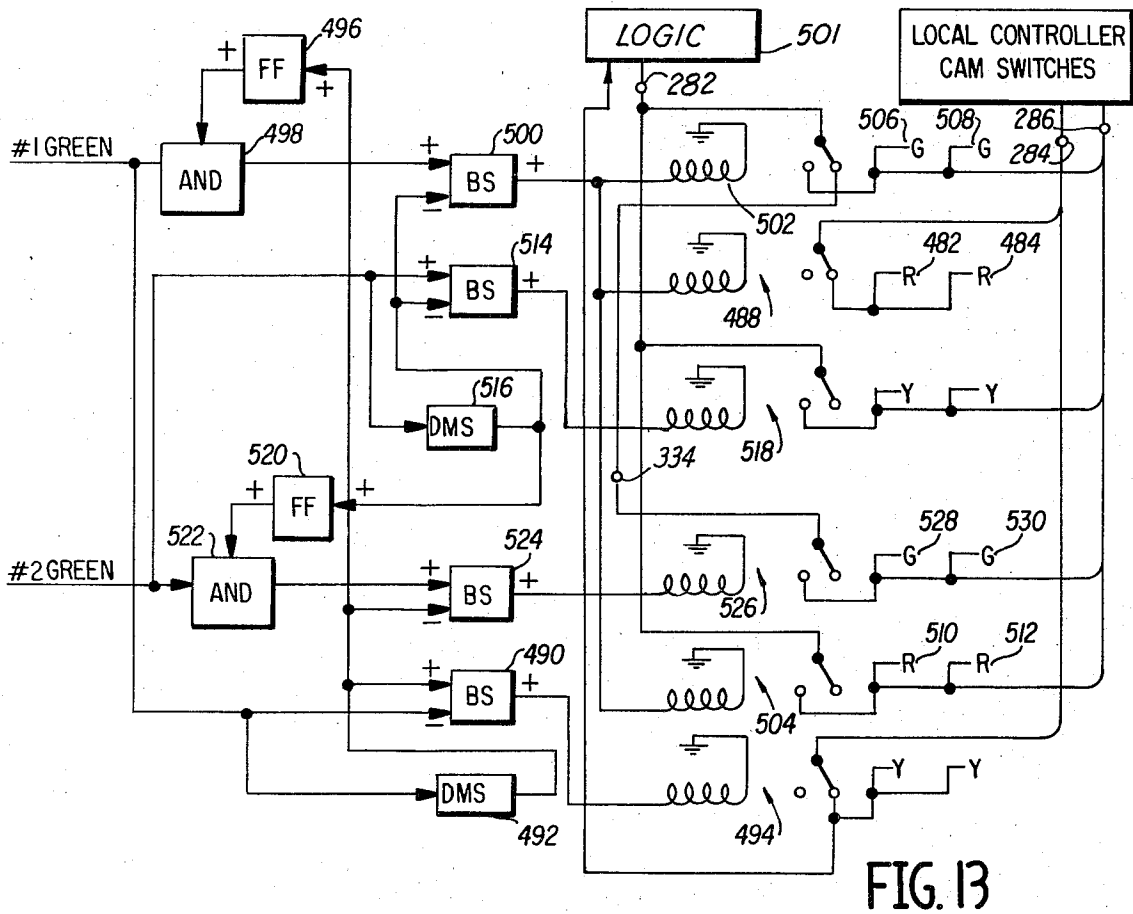

FIG. 13

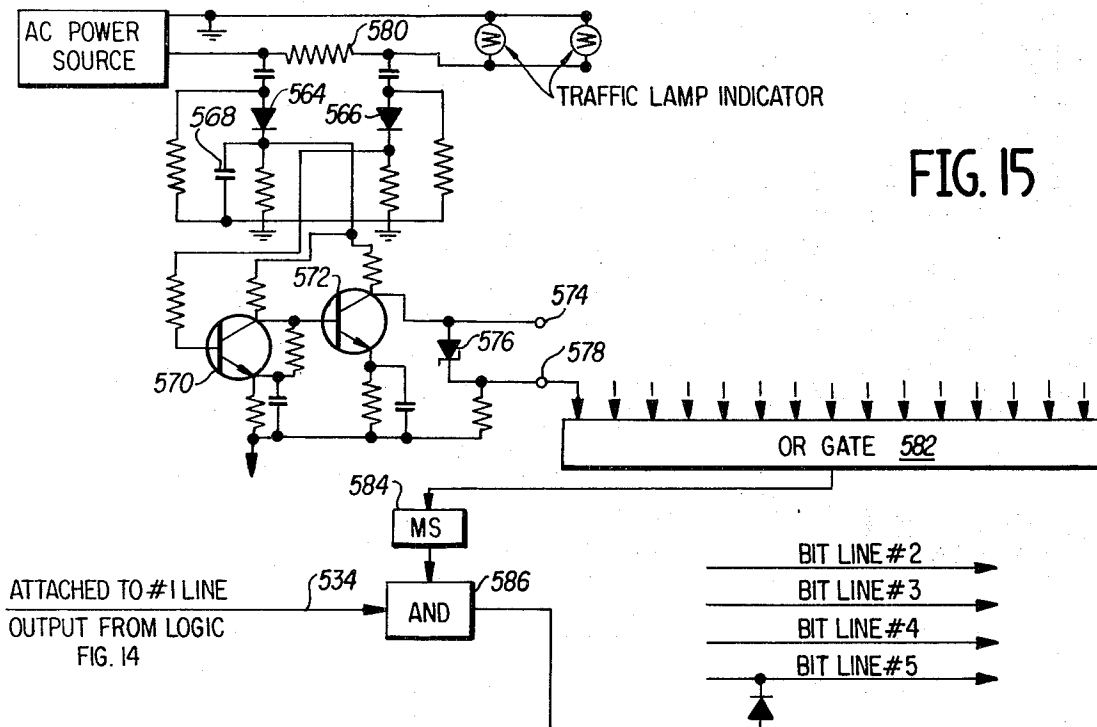

FIG. 15

ATTACHED TO #1 LINE
OUTPUT FROM LOGIC
FIG. 14

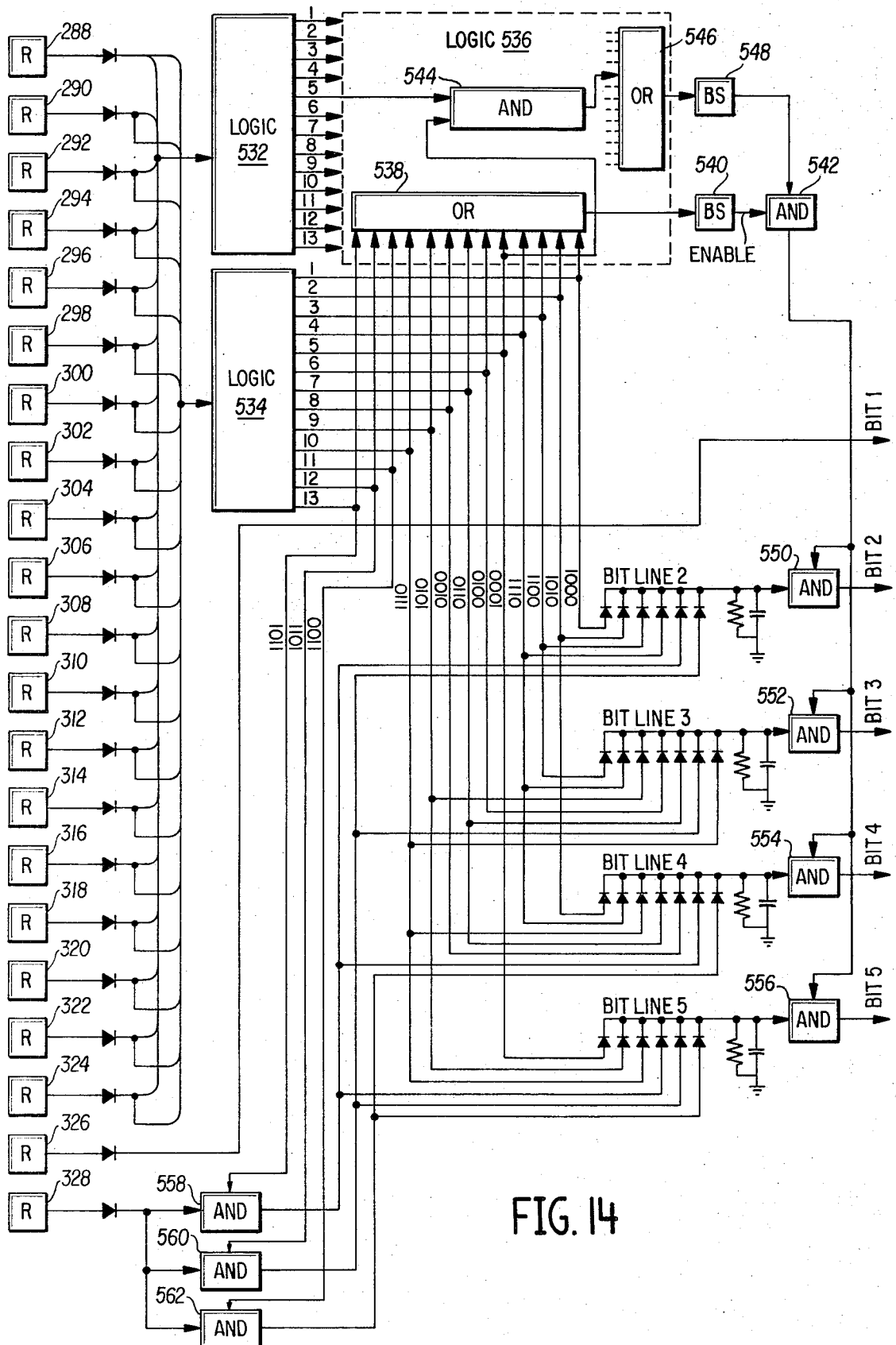

FIG. 14

AUTOMATIC TRAFFIC CONTROL SYSTEM

BACKGROUND OF THE INVENTION

1. Field Of The Invention

This invention relates generally to communication networks, and more particularly to an automatic communication system for use in traffic control.

2. Description Of The Prior Art

In metropolitan areas with populations greater than 100,000, the vehicular traffic and transportation environment is becoming more complex, and satisfactory control of vehicular traffic flow presents many problems. In some areas attempts are being made to solve the varied problems by implementation of centralized, computer operated traffic control systems. Whether the computer utilized is analog or digital, significant problems exist in providing adequate communications between the central facility and the individual traffic control devices which are located on the street.

Most existing systems require essentially one dedicated line of communications from the central facility to each individual remote traffic control device. A remote traffic control device may be a conventional signal light or traffic light located at a highway or street intersection, for example. Naturally, in any city of reasonable size, hundreds, or perhaps thousands of such individual signal lights are required to keep traffic flowing smoothly. Consequently, hundreds or thousands of individual communication lines are required, to make such presently existing systems operational.

In addition, where various types of vehicle detection devices are utilized, individual communication lines are also required for these units. Vehicle detection devices may detect the presence of a vehicle or measure other data related to vehicular traffic flow, such as vehicle speed. Vehicle detection devices may be located on the streets immediately adjacent to an intersection or they may be spaced along a street or arterial. The data furnished by vehicle detection devices may be utilized in a computer facility to establish, compute, or select a desired traffic flow plan for the indicated traffic conditions.

In any centralized traffic control system, this current practice of utilizing a single, dedicated communication line to each traffic control device or vehicle detector can be extremely expensive and can result in the need for a large amount of complex interface equipment. The initial installations of the many separate communication lines required are also costly. In addition, if the lines are leased from the local Telephone Company, the continuing lease costs of many lines can be significant, particularly for the larger systems.

Consequently, there is a need for an automated traffic control system that includes an efficient and relatively inexpensive communication link between its central control facility and each remote traffic control device and vehicle detector.

SUMMARY OF THE INVENTION

Accordingly, one object of this invention is to provide a novel automated traffic control system which includes a highly simplified communication network.

Another object of this invention is to provide an automated traffic control system including a communication network which is relatively inexpensive to maintain.

Yet another object of this invention is to provide an automated traffic control system including a communication network which is relatively simple and inexpensive to install.

A further object of this invention is to provide an automated traffic control system in which the central control facility is linked to a plurality of remote traffic control devices and vehicle detectors over a single communication line.

Another object of this invention is to provide a novel computer controlled automated traffic control system.

A still further object of this invention is to provide an automated traffic control system having novel remote terminal systems.

Yet another object of this invention is to provide an automated traffic control system including emergency vehicle locators.

Another object of this invention is the provision of an automated traffic control system which expedites the travel of emergency vehicles in urban areas.

Briefly, these and other objects of the invention are achieved by providing a central control facility including a computer linked through interface equipment to a master transceiver. The master transceiver is coupled to a communication link, which is preferably equivalent to a voice grade, noncompensated telephone line, and controls the flow of information over the communication link. A plurality of remote terminals are coupled in parallel, party line fashion to the communication link throughout an urban area. Each remote terminal may include a remote transceiver and interface equipment which may be coupled to a traffic control device, as well as coupled to a vehicle detector or an emergency vehicle locator.

BRIEF DESCRIPTION OF THE DRAWINGS

A more complete appreciation of the invention and many of the attendant advantages thereof will be readily appreciated as the same becomes better understood by reference to the following detailed description when considered in connection with the accompanying Drawings wherein:

FIG. 1 is a block diagram illustrating the general arrangement of components in the automated traffic control system of the instant invention;

FIG. 2 is a six-part timing diagram illustrating the operation of the Master Transceiver of FIG. 1;

FIG. 3 is a four-part timing diagram illustrating the operation of the Remote Transceiver illustrated in FIG. 1;

FIG. 4 is an expanded block diagram of the Modulator and Response Receiver sections of the Master Transceiver of FIG. 1;

FIG. 5 is an expanded block diagram of the Logic section of the Master Transceiver of FIG. 1;

FIG. 6 is an expanded block diagram of the Sync Detector, Data Receiver and Response Modulator sections of the Remote Transceiver of FIG. 1;

FIG. 7 is an expanded block diagram of the Logic section of the Remote Transceiver of FIG. 1;

FIG. 8 is a block diagram of an output circuit which may be coupled to the Logic section of the Remote Transceiver illustrated in FIG. 7;

FIG. 9 is an expanded block diagram of the first logic network illustrated in FIG. 8;

FIGS. 10A, 10B and 10C illustrate is an exemplary circuit and logic diagram for remote control of a six-street intersection;

FIG. 11 is an exemplary circuit and logic diagram illustrating on an expanded scale a portion of the circuit of FIG. 10, showing a remote control circuit for operating the indicator lights for one street of the six-street intersection;

FIG. 12 is a circuit and block diagram illustrating a system for expediting the travel of emergency vehicles;

FIG. 13 is a circuit and block diagram illustrating a system for controlling a simple two-street intersection;

FIG. 14 is a circuit and block diagram illustrating an interface network for coupling response signals from traffic light indicators at a given intersection with the associated remote unit;

FIG. 15 is a schematic diagram of an burn-out detection circuit; and,

FIG. 16 is a block diagram of vehicle detector interface equipment which may be used in the instant invention.

DESCRIPTION OF THE PREFERRED EMBODIMENT

I. GENERAL

Referring now to the Drawings, wherein like reference numerals designate identical or corresponding parts throughout the several views, and more particularly to FIG. 1 thereof, the instant invention is shown as including a Central Facility 10 for the control of traffic and transportation. Contained within the Central Facility 10 are a Computer 12, Computer Interface Equipment 14, and a Master Transceiver 16. If desired, a Visual Display Board 18 may be utilized to indicate the current status of all remote traffic devices 20, 30 and 32. The Master Transceiver 16 is connected to a Communication Link 22, which includes a single communication line. This line may be equivalent, for instance, to a voice grade, non-compensated telephone line. Such a line can be connected through a multiplicity of telephone exchanges if necessary. Also other communication links identical to 22 can be operated from the Master Transceiver 16, if desired.

Spaced along the communication line at arbitrary distances are Remote Terminals 24 which are connected to the Communication Link 22 in parallel, party line fashion. Each Remote Terminal includes a Remote Transceiver 26 for use with a locally attached Traffic Control Device 20. The Remote Transceiver 26 includes Interface Equipment 28 for coupling it to the attached Traffic Control Device 20. The Remote Transceiver permits appropriate remote control of the Traffic Control Device as well as a locally controlled operation of the Traffic Control Device. A Vehicle Detector 30 may be connected locally through Interface Equipment 28 to a nearby Remote Transceiver 26 to the Communication Link 22, or a separate Remote Transceiver may be used to couple a Vehicle Detector to the Communication Link 22. An Emergency Vehicle Locator 32, comprising auxiliary receiver equipment, may be included in each Remote Terminal 24 such that emergency vehicle information can be appropriately transmitted through the Remote Transceiver 26 to the Central Facility, when desired.

Within the Central Facility 10, the Computer 12 may be either analog or digital. A digital computer is superior for the present purpose since its possible applications are more varied and more flexible. Based on input vehicular traffic data, the software package of the Computer 12 can be constructed for computation of an appropriate traffic control plan or for specific selection of one of several programmed traffic control plans. The appropriate control data are transmitted in the form of commands to each Remote Transceiver. In addition, the computer facility can be utilized for record keeping and appropriate production of hard copy records.

In the Central Facility 10, the Interface Equipment 14 has a two-fold function: (1) It couples coded command data from the Computer 12 to the Master Transceiver 16; and (2) it receives coded response information from the Master Transceiver and couples this data to the Computer.

In the Central Facility, the Master Transceiver equipment generates all pulse timing and frequency information for operation of the Communication Link 22. Appropriate timing signals are input to the Computer 12 via the Interface Equipment 14. In addition, output command data, via the Interface Equipment, are processed and appropriately multiplexed onto one or more Communication Links. Appropriate synchronization information is also generated in the Master Transceiver 16 and appropriately multiplexed onto the Communication Link 22.

At each Remote Terminal 24, the Remote Transceiver 26 is appropriately coupled to the Communication Link 22 in parallel with other remote units on the same communication line. Each remote unit is automatically and periodically synchronized by means of the data received from the Central Facility 10. For each remote unit, this enables specific reception of its own command data. These commands are demodulated and processed for application to the attached Traffic Control Device 20, which may be conventional traffic lights, for example. The locally processed data are coupled to the attached Traffic Control Device by means of Interface Equipment 28. This circuitry applies power to the appropriate lamp indicators of the local Traffic Control Device. This same interface circuitry is responsive to the existent state of the lamp indicators. These response signals are processed and coupled to the attached Remote Transceiver 26, where they are further processed and modulated onto the Communication Link 22. Appropriate reception of these response signals occurs at the Central Facility 10, and furnishes one part of the information input to the Computer 12.

In systems which utilize vehicle detection devices, a second category of information can be input to the Computer 12. Data gathered by a vehicle detection device of Vehicle Detector 30 may be coupled by wire to a nearby Remote Transceiver 26 via Interface Equipment 28 for subsequent transmission to the Central Facility 10. On the other hand, each vehicle detection device may be utilized with its own Remote Transceiver. In either case, the data are processed and appropriately multiplexed onto the Communication Link 22 to be utilized by the Computer for generation or selection of an appropriate traffic flow plan.

In systems where it is desired to locate emergency vehicles, additional receiver circuitry 32 can be included with each Remote Transceiver 26 at each controlled

intersection. Sequential response to emergency vehicles as they proceed through a controlled intersection can be generated by the additional receiver circuitry. This information can be processed and appropriately multiplexed onto the attached Communication Link 22. Emergency vehicle data detected at the Central Facility need not be computer processed, except for record keeping purposes. An appropriate Visual Display Board as illustrated at 18 may be used for analyzing this information

The remote control and associated processing of discrete data to and from the Remote Terminals 24 can be accomplished by appropriate time division multiplexing. The circuitry discussed herein is relatively simple and inexpensive.

A timing diagram for the cyclic operation of the system as a whole provides a description of the general system operation. Referring now to FIG. 2, the Central Control Facility 10 time base is depicted in part (a). Several count values and count periods are indicated, which will be discussed subsequently in more detail. A syn alert gate defined by each of pulses 34 and 36 is shown in part (b) of the figure. It is noted that the term "pulse" is used merely as a convenient term designating the rectangular waveforms shown in the Drawings. Transmitted data contained in this period are utilized for arming of Remote Transceivers 26 for subsequent sync reception. A data transmission gate defined by a pulse 38 is shown in part (c) of the figure and extends for approximately one-third of the total cycle time. All data from the Master transceiver 16 are transmitted during this time, including sync data and individual, discrete command data for each Remote Terminal 24. The syn gate defined by a pulse 40 is shown in part (d) of the figure. During this time, precise synchronization data may be transmitted in the form of a binary coded word. The data input gate defined by a pulse 42 is shown in part (e) of the figure. It is during this time that actual commands are transmitted to each remote unit. The response interval defined by a pulse 44 is depicted in part (f) of the figure. The extent of this interval comprises essentially the remaining two-thirds of the total cycle time. It is during this time that all data responses from all Remote Terminals 24 are transmitted at the remote location and received at the Central Facility 10. Vehicle Detector 30 responses as well as Emergency Vehicle Locator 32 data may be included in the response interval.

Referring now to FIG. 3, part (a), the time base of a Remote Transceiver 26 is depicted. Local counts and count periods are indicated which will be discussed subsequently in more detail. The sync interval gate defined by a pulse 46 is shown in part (b) of the figure. It is during this time that a Remote Transceiver 26 is synchronized, first by coarse sync and second by fine sync signals. The command interval gate defined by a pulse 48 is shown in part (c) of the figure. It is during this time that the particular, discrete command to a given Remote Terminal 24 is received, demodulated, and processed. The response interval gate defined by a pulse 50 is shown in part (d) of the figure. It is during this time that an individual Remote Transceiver 26 processes and modulates data for transmission back to the Central Facility 10.

Other procedural arrangements may be utilized with respect to time sharing on a communication link. For instance, an individual command could be transmitted

to the first Remote Terminal or unit. This first Remote Terminal could then respond to the received command and transmit the response back to the Central Facility 10. A second command could then be transmitted to the second Remote Terminal over the same communication line used with the first Remote Terminal. This process would be repeated for each attached Remote Terminal. However, in the preferred embodiment, the procedures refer to a time base construction similar to that depicted in FIGS. 2 and 3.

II. TIMING BASE DESCRIPTION FOR PREFERRED EMBODIMENT OF THE COMMUNICATION LINK SYSTEM

The communication cycle is a serial operation comprised of synchronization signals and commands, which are transmitted from the Central Facility 10, and response signals, which are transmitted from the Remote Transceivers 26. In a Remote Terminal 24, the particular command to the Remote Terminal is detected and stored during each communication cycle. The cycle length can be changed or adjusted for any practical extent in time. This cycle length is not directly related to the cycle times of traffic signal devices, and in general, the communication cycle time is less than a few seconds, while a traffic signal device cycle time may extend for many seconds, perhaps minutes. On the other hand, it is possible to maintain absolute timing of an attached Traffic Control Device to less than one second.

The Central Facility time base shown in FIG. 2 will be described in greater detail. This time base may be incremented, for instance, at a rate of 3,600 Hz, determined from a master crystal-controlled oscillator to be described hereinafter. The start of a communication cycle occurs at count 0, referenced as t_0 in FIG. 2(a), and extends for 7,610 counts. Count 7611 is coincident with count 0, at which time the master counter is reset to zero, and the cycle repeats.

After activation of the Communication Link 22 and towards the end of each communication cycle, a Sync Alert Gate pulse 34 occurs. This is shown in FIG. 2(b) and occurs from count 7251 to count 7301. During this time interval, a low frequency tone may be transmitted, for instance, 750 Hz. This tone may be utilized to signal all attached Remote Transceivers 26 that a synchronization interval will occur as the next event. Reception and detection of this frequency tone in each Remote Transceiver may be considered as establishment of coarse synchronization.

At count 7301, the Data Transmit Gate pulse 38 occurs. This gate is shown in FIG. 2(c) and extends through count 0 to count 2301. During the first part of this gate, a string of binary zones may be transmitted at the carrier frequency to count 30. Reception and detection of this signal in each Remote Transceiver establishes a stable carrier reference for subsequent data decoding.

A Sync Gate pulse 40 occurs from count 30 to 51 as shown in FIG. 2(d). During this interval a fine-sync code word may be transmitted at the carrier frequency. Reception and detection of the fine-sync word in each remote unit may be considered as establishment of fine synchronization.

A Data Input Gate pulse 42 occurs from count 51 to count 2301, as shown in FIG. 2(e). During this interval,

all command data are transmitted from the Central Facility 10 to all attached Remote Terminals 24.

A Response Gate pulse 44 occurs from count 2301 to count 7251, as shown in FIG. 2(f). During this interval, all response data are transmitted from all attached Remote Terminals to the Central Facility 10.

A typical Remote Transceiver 26 time base is depicted in FIG. 3(a). A remote time base may be referenced to the Central Facility 10 time base by establishment of the time T_0 . For instance, a remote unit clock circuit (to be described hereinafter) may be operated at 1,200 Hz. This frequency also may be established as the bit rate. If this bit rate is utilized, the remote clock pulses will occur at one-third the rate of the Central Facility clock pulses.

In a remote unit, reception and detection of the low frequency tone automatically establishes a sync interval as depicted by a pulse 46 in FIG. 3(b). Subsequent reception and detection of the reference carrier signal and the fine-sync code word establishes T_0 in each Remote Transceiver. At this time, a Remote Transceiver counter is reset to zero.

The total command interval for a Remote Transceiver occurs from T_0 to count 750, as shown by a pulse 48 in FIG. 3(c). The total response interval for a Remote Transceiver occurs from count 750 to count 2400, as shown by a pulse 50 in FIG. 3(d). Approximately at the time of count 2400, a given Remote Transceiver will receive the low frequency Sync Alert Tone, and the communication cycle will repeat.

The command data for all attached Remote Terminals are transmitted from the Central Facility commencing at count 51, FIG. 2(a). These data are transmitted serially in the form of binary ones and zeros. The command data to any particular Remote Transceiver may comprise, for instance, two, three, four, or five bits. The first bit indicates the mode of control for a particular Remote Transceiver. Thus, a binary one for the first bit signifies the Remote Control Mode, and the particular remote unit will permit the attached traffic signal device to be controlled by commands issued at the Central Facility. If the first bit is a binary zero, the Local Control Mode is indicated, and the particular remote unit will cause the attached traffic signal device to be controlled by the Local Controller at the Traffic Control Device.

If the first bit is a binary one, the remaining one, two, three, or four bits may consist of some combination of binary ones and zeros. Dependent on the number of required functions of the attached traffic signal device, these remaining one, two, three, or four bits may be utilized to convey, respectively, two, four, eight, or 16 discrete commands. Therefore, the associated Remote Transceiver 26 may be adjusted to accept its own required number of command bits. Correspondingly, the command interval allotted to a given remote unit must be at least equal in extent to the required number of command data bits.

The response signals from each remote unit represent the existent state of any attached traffic device. Thus, the response signals can represent the existent state of on-the-street lamp indicators for an attached traffic signal device, or the existent state of a vehicle detection device, or information relating to the presence of a particular emergency vehicle.

III. DESCRIPTION OF PREFERRED MASTER TRANSCEIVER CIRCUITRY FOR THE COMMUNICATION LINK SYSTEM

The Master Transceiver 16 may comprise, for instance, a Modulator 52, a Response Receiver 54, and a Logic section 56. Block diagrams of the Modulator 52 and Response Receiver 54 sections are shown in FIG. 4. A block diagram of the Logic section 56 is shown in FIG. 5.

The Modulator section 52 accepts input synchronization and command data from a multiplexer 58 in Logic section 56 (FIG. 5) and modulates the carrier with this input. The Modulator 52 is controlled by two gate signals which are generated in the Logic section 56. These signals are labeled as the Data Transmission and the Sync Alert Gates in FIG. 4. The Data Transmission Gate enables a Bi-Phase Modulator 60, and the Sync Alert Gate enables a Sync Oscillator 62. The Sync Oscillator 62 produces a low frequency tone, for instance, 750 Hz, which is coupled to a Summing Amplifier 64. After the Sync Alert Gate, the Data Transmission Gate allows the Bi-Phase Modulator 60 to accept input data. A carrier frequency, for instance, 1,800 Hz, may be generated in the Logic section 56 and coupled to the Bi-Phase Modulator 60. The input data modulate the carrier in a synchronous manner, such that input binary zeros and ones produce, respectively, 0 and π radians of phase shift on the carrier signal.

The Summing Amplifier 64 combines the modulated carrier and the low frequency Sync Alert signal, amplifies these signals and couples the output to an Isolation Transformer 66. The Summing Amplifier 64 produces the proper signal power and impedance levels, for instance, for driving a voice grade telephone line or equivalent Communication Link 22. The Isolation Transformer 66 may convert the unbalanced output signals from the Summing Amplifier 64 to balanced signals for transmission over the attached Communication Link 22.

The Isolation Transformer 66 also couples input response signals from the Communication Link 22 to the Response Receiver section 54 of the Master Transceiver 16. These signals are the response signals from each attached Remote Terminal 24. These signals, for instance, may be in the form of a binary, pulse amplitude modulated (PAM) 1,800 Hz carrier. Response signals are coupled through an analog AND gate 68 to a Response Signal Amplifier 70. AND gate 68 is enabled by the Response Gate generated in the Logic section 56.

The Response Signal Amplifier 70 provides sufficient gain to drive a Full Wave Rectifier 72. This rectifier converts the bipolar response carrier pulses into unipolar signals. The Full Wave Rectifier 72 is coupled to a Comparator 74 which compares the rectified input signal with a reference voltage which may be set at a predetermined threshold value. The threshold value is set above the average line noise and below the minimum expected signal level. If an input signal to the Comparator 74 is above the threshold procedures convert the unipolar PAM signals into a series of constant voltage amplitude pulses. The resultant pulses are fed into a Low Pass Filter 76 which sets the signal band width and shapes the Comparator output. The Low Pass Filter output will cause a delay of about one-third of a bit time for each input data bit. Otherwise, this output rep-

resents the data bit stream as transmitted from the Remote Terminals 24.

The remaining circuitry in the Response Receiver section 54 converts the detected response data stream into digital data suitable for processing, for instance, by digital Computer 12, via Interface Equipment 14. The response data stream is coupled to two separate circuits. One circuit generates timing signals which are utilized to decode the data, and a second circuit shapes the input data for acceptance and storage in a Shift Register circuit.

For the first circuit, response data pulses are coupled to a first Differentiator 78. The first initial input data pulse is differentiated in the first Differentiator 78 and the leading edge of this pulse is utilized to set a first Bistable circuit 80. Immediately when first Bistable circuit 80 is set the output gate from first Bistable circuit 80 releases a Master Response Bit Clock circuit 82. This clock is adjusted to free run approximately at the data bit rate, for instance, 1,200 Hz. Immediately upon release, the Master Response Bit Clock 82 generates a bit clock pulse, for instance, 10 to 25 microseconds in extent. These Bit Clock pulses continue approximately at the bit rate, until first Bistable circuit 80 is reset by means of a pulse from the Logic section 56.

The output gate from first Bistable circuit 80 also is coupled to a second Differentiator 84. The differentiated output is utilized to set a second Bistable circuit 86 and to reset a Response Counter 88 to zero. In the set state, second Bistable circuit 86 output enables an AND Gate 90 such that the Response Bit Clock pulses are coupled to the Response Counter circuit 88 and to a Bit Clock Delay 92. The Response Counter 88 accumulates six bit clock counts, which corresponds to five complete bit time intervals, including the first initial input data bit. At the end of the 5-bit interval and coincident with the sixth count, the Response Counter circuit 88 generates a reset pulse to second Bistable circuit 86. Consequently, the enable gate to AND Gate 90 is removed, and no further Bit Clock pulses are passed. In addition, a reset pulse from the Logic section 56 is coupled to first Bistable circuit 80 which resets this Bistable circuit. In the reset state, first Bistable circuit 80 disables the Master Response Bit Clock 82. The actual time of the reset pulse to first Bistable circuit 80 occurs just prior to the minimum time possible for input of the next group of response data bits in the next sequential response time interval. Precise timing distinction between the reset-time of first Bistable circuit 80 and an immediately following set-time is augmented by the slight delay of data pulses as they occur from the Low Pass Filter circuit 76. Thus, it will be impossible to attempt setting of first Bistable circuit 80 at the same time that it is being reset by the pulse from the Logic section 56. The output Bit Clock pulses from AND Gate 90 are coupled to the Bit Clock Delay circuit 92. In this circuit, a delay of about one-half bit time is generated and the delayed clock pulses are coupled to a Shift Register 94.

In the second circuit, response data pulses are coupled directly from the Low Pass Filter 76 to a Data Shaper 96. The Data Shaper 96 shapes the response data pulses and couples them to Shift Register 94. The input Bit Clock pulses to the Shift Register 94 are utilized to clock response data bits into the Shift Register Circuit. For instance, the first delayed Bit Clock pulse occurs at a time which is coincident with the time of the

first data bit from the Data Shaper 96. This coincidence enables sampling of the response data bit pulse at the approximate midpoint, and permits storage of the value of this response data bit in the Shift Register 94. When five response bits have been stored in the Shift Register 94, a pulse from Logic Section 56 can be used to cause the Shift Register to dump its contents into a Response Storage Register 98. Towards the end of a communication cycle, for instance, at count 7251, the contents of the Response Storage Register 98 may be dumped into the attached Computer facility 12. Use of a Response Storage Register permits rapid dumping of all response data which have been accumulated during one communication cycle, and further enables more efficient usage of an attached, on-line, real-time, digital computer, as illustrated at 12. The response data bits may be utilized in the computer to generate appropriate output commands.

A preferred embodiment of the Logic section 56 is shown in FIG. 5. The logic circuitry may be utilized to generate all timing information for the operations of the Central Facility 10, for instance, timing for the communications cycle, synchronization signals, command signals, and response signals. The Logic section 56 contains a crystal controlled oscillator 100, which, for instance, may produce a continuous 180 kHz signal. All timing functions can be derived from or synchronized with this clock signal. The 180 kHz signal may be divided by 50, for example, in a first Frequency Divider 102 to produce a 3,600 Hz clock. The 3,600 Hz clock may be divided by 2 in a second Frequency Divider 104 to produce an 1,800 Hz clock, and by 3 in a third Frequency Divider 106 to produce a bit Clock of 1,200 Hz. Finally, the 3,600 Hz clock may be coupled to a fourth Frequency Divider 108 which is a gating circuit utilized with the response time interval.

A Master Counter 110 utilizes the 3,600 Hz clock input to produce a number of output timing pulses. The total communication cycle time may be determined, for instance, by the 7610 count output, which resets the Master Counter 110 to zero, coincident with the 7611th count. The 7610 count output is also utilized for reestablishing zero phase in the first, second, and third Frequency Divider circuits 102, 104 and 106.

The 7251 count output pulse sets a first Bistable circuit 112, which generates, at one of its outputs, the Sync Alert Gate. This gate is utilized in the modulator section to release the Sync Oscillator 62. Count 7251 also resets a fourth Bistable circuit 114. In the reset state, the Fourth Bistable circuit 114 couples a logical 1 from its \bar{Q} output to an AND Gate 116. Count 7301 resets the first Bistable circuit 112. In the reset state, the first Bistable circuit 112 couples a logical 1 from its \bar{Q} output to AND Gate 116. These two inputs to AND Gate 116 produce the Command Data Gate at the output of and Gate 116. The 7251 count output pulse also is utilized in the Response Receiver section 54 to dump the response data in Storage Register 98 into the computer facility 12.

The 0030 count output pulse sets a second Bistable circuit 118. In the set state, the second Bistable circuit 118 generates the control gate for use in a Sync Word Generator 120. The 0051 count output pulse resets the second Bistable circuit 118 which removes the control gate.

The 0051 count output pulse also sets a third Bistable circuit 122. In the set state, the third Bistable circuit

122 generates the Data Input Gate. The 2301 count output pulse resets the third Bistable circuit, which terminates the Data Input Gate.

The 2301 count output pulse also sets the fourth Bistable circuit 114. In the set state, the fourth Bistable circuit 114 generates the Response Gate at its Q output. The fourth Bistable circuit is reset by the 7251 count output pulse, as mentioned above.

The third Frequency Divider 106 applies 1,200 Hz bit clock pulses to the Sync Word Generator 120. The Sync Gate output from the second Bistable circuit 118 enables the Sync Word Generator 120, such that a fine-sync code word, for instance, 0001100, may be produced and coupled to the Multiplexer 58.

The Multiplexer 58 accepts the sync word during the Sync Gate time and accepts the computer generated commands during the Data Input Gate time. The computer generated commands could also be stored once each communication cycle in a Storage Register (not shown), such that these commands are appropriately processed into the Multiplexer 58 during the Data Input Gate time. Thus, the Multiplexer 58 permits the sync word to be time division multiplied with the data bits from the Computer 12.

The Q output of the fourth Bistable circuit 114 provides the Response Gate, as mentioned above. The Response Gate is coupled to the Response Receiver section 54 and enables analog AND gate 68. The Response Gate also enables the fourth Frequency Divider 108 in the Logic section 56. Thus, the 3,600 Hz clock is divided by 33 in this circuitry, beginning, for instance, at count 2301 and terminating at count 7251. The difference count between these two counts is 4950, which, after division by 33, produces 150 Response Time Base output pulses. These pulses occur, for instance, at 150 equally spaced intervals of time. They furnish the Response Time Base input signals to reset the first Bistable circuit 80 and to dump the contents of Shift Register 94 into the Response Storage Register 98. Finally, the Response Gate from the fourth Bistable circuit 114 output is utilized to enable AND Gate 68, such that all response data signals from the Communication Link 22 may be coupled to the Response Signal Amplifier 70, shown in FIG. 4.

IV. DESCRIPTION OF PREFERRED REMOTE TRANSCEIVER CIRCUITRY FOR THE COMMUNICATION LINK SYSTEM

A Remote Transceiver 26 may comprise, for instance, a Sync Detector 124, a Data Receiver 126, a Response Modulator 128, and a Logic section 130. Block diagrams for the first three sections are shown in FIG. 6. A block diagram of the Logic section is shown in FIG. 7.

A Remote Transceiver 26 receives and detects coarse and fine synchronization information, demodulates and processes a discrete group of data signals corresponding to its own command data, and processes, modulates, and transmits its response data to the Central Control Facility 10. The response data may correspond to the existent state of an attached Traffic Control Device 20, or an attached Vehicle Detector device 30. Response data may also include information from an Emergency Vehicle Locator 32.

Signals transmitted from the Central Control Facility 10 may be fed to each Remote Transceiver 26 through an Isolation Transformer 132, for instance, as shown in

FIG. 6. In a remote unit, the Isolation Transformer 132 is coupled to an Amplifier 134 for received input signals, and it is coupled to another amplifier 136 output via a Relay 138 for transmission of response signals to the attached Communication line (i.e., Communication Link 22).

Discussion of the various circuit functions will follow the sequence of events as they occur in real time. Sync detection is the first major event preceding any given communication cycle in a remote unit. Synchronization may be established from circuit functions which can occur, for instance, in three sequential events. The first event may be related to the Sync Alert signal which can be a low frequency, for instance, a 750 Hz tone. This signal is amplified in Amplifier 134, coupled to a Limiter 140, and subsequently, coupled to a Differentiator 142. This low frequency tone does not cause detrimental responses in other circuits which are coupled to the output of Amplifier 134 or to the output of Limiter 140.

Limiter 140 removes any amplitude variations from input signals and produces a constant amplitude output. However, the phase of input signals is not altered by the action of Limiter 140. For the Sync Alert tone, the output of Limiter 140 is coupled to Differentiator 142, which produces a stream of narrow positive pulses at a rate equal to the positive zero crossing rate of the Sync Alert tone. These positive output pulses from Differentiator 142 are coupled to Monostable Delay circuit 144, which delays each pulse in time by an amount which is slightly less than the period of the Sync Alert tone. For instance, if 750 Hz is utilized for the tone with a period of approximately 1.3 milliseconds, the inserted delay might be approximately 1.2 milliseconds. These delayed output pulses are coupled to a Window Monostable circuit 146, which generates a relatively narrow gate for each delayed input pulse. The duration of the output of the Window Monostable 146 is adjusted such that the generated gate or window will bracket the anticipated time of the next sequential pulse of the Sync Alert tone from Differentiator 142. This coincidence, if it occurs, is established in the Correlation Gate circuitry 148, which is enabled by the output of the Window Monostable 146. The output pulses from Differentiator 142 also are input to the Correlation Gate 148. Therefore, if the proper rate of pulses occurs, these pulses will pass the Correlation Gate 148 and be coupled to the Sync Arm Detector 150. It should be noted that, if the pulses which are input to Monostable Delay 144 occur at a higher rate than that anticipated for the Sync Alert tone, Monostable Delay 144 will block, and no output pulses are coupled to the Window Monostable circuit 146.

The Sync Arm Detector 150 examines the input pulse rate from the Correlation Gate circuitry 148. An output to Monostable Delay 152 is produced only if a specified number of pulses are accumulated in the Sync Arm Detector 150 within a predetermined time interval. When an output is produced from the Sync Arm Detector 150, Monostable Delay 152 is initiated. This circuitry is adjusted to generate a delayed output pulse immediately prior to the anticipated time for occurrence of the Fine Sync word. For the circuitry described herein, a delay of approximately 93 milliseconds is adequate. The output of Monostable Delay 152 initiates a Sync Window Monostable 154 which outputs a Fine-Sync Window Gate. The extent of this gate may

be approximately 10 milliseconds. The output of Sync Window Monostable 154 is coupled to AND Gates 156, 158 and 206, and is utilized to enable these gates.

The second event in the synchronization interval may be related to the establishment of a stable carrier reference. Immediately following the Sync Alert tone, a burst of unmodulated carrier may be transmitted from the Central Facility 10. For instance, 1,800 Hz may be utilized as a satisfactory carrier frequency. The burst of unmodulated carrier may be received and amplified in Amplifier 134 and coupled to a Frequency Multiplier 160. These carrier signals do not cause detrimental responses in other circuits which are coupled to the output of Amplifier 134. The Frequency Multiplier 160 produces full wave rectification of the input carrier and generates second harmonics of the carrier. The rectified output is amplified in an Amplifier 162 and coupled to a Band Pass Filter 164. If an 1,800 Hz carrier frequency is utilized, this filter may be designed to suppress frequencies other than the second harmonic frequency of 3,600 Hz. This second harmonic signal is utilized to obtain and maintain a stable reference for demodulation of data from the carrier. The output of Band Pass Filter 164 is limited in a Limiter 166 and subsequently coupled to a Phase Detector 168. Phase Detector 168, a Low Pass Filter 170, and a Voltage Controlled Oscillator 172 comprise a phase-lock-loop circuit. Phase Detector 168 compares the phase of the input second harmonic of the carrier with the phase of the output from the Voltage Controlled Oscillator 172. Any difference in phase is detected as the loop phase-error and is filtered by Low Pass Filter 170. This filtered phase-error is utilized to correct the phase of the Voltage Controlled Oscillator 172, which ultimately maintains an output signal in phase quadrature with the input second harmonic of the carrier. The output of the Voltage Controlled Oscillator 172 also is coupled to a Frequency Divider 174 via a Phase Shifter 176. The Frequency Divider 174 halves the input frequency, thus regenerating the carrier frequency. Therefore, a stable carrier reference signal is generated, which may be utilized as the reference phase for a Phase Detector 178. Phase Detector 178 functions as the phase detector of the modulated carrier for all input data signals. It should be noted that the carrier phase reference which has been generated will be either in phase (0°) with the real input carrier or out of phase (180°) with the real input carrier. This circumstance is a result of the second harmonic generation in the Frequency Multiplier 160. This phase ambiguity will be determined subsequently by the Fine-Sync Detection circuit.

The third event in the synchronization interval may be related to Fine-Sync detection. Immediately following the burst of unmodulated carrier, a Fine-Sync word may be transmitted from the Central Facility 10. For instance, the word may comprise a 7-bit code word such as 0001100. This code word may be received and amplified in Amplifier 134, coupled to Limiter 140, and subsequently coupled to Phase Detector 178. The code word does not cause detrimental responses in other circuits. Phase Detector 178 compares the phase of the input modulated carrier with the reference carrier phase. The output of Phase Detector 178 comprises signals which correspond to phase modulation of the input carrier, which, in the present instance, correspond to the binary zeros and ones of the 7-bit code

word. The output of Phase Detector 178 is coupled through a Low Pass Filter 180 to a Data Shaper 182. Corresponding to the input signals, the Data Shaper 182 generates a binary, unipolar wave output. This output comprises an estimate of the transmitted data stream. The output of Data Shaper 182 is coupled to a Differentiator 184 and to a 4-bit Shift Register 186.

The output of Differentiator 184 is coupled to a Full Wave Rectifier 188. The resultant output of this rectifier comprises a stream of positive pulses which occur at the transitions of the input data stream. For instance, for the input Sync word 0001100, the output pulses from the Full Wave Rectifier 188 will occur at the beginning of the fourth bit and at the beginning of the sixth bit. If the Sync word occurs at the prescribed time, AND Gate 156 will be enabled and will couple the first one of these Full Wave Rectifier output pulses to an AND Gate 190. In addition, the output of the Sync Window Monostable 154 is coupled to a Bistable 192 which sets this Bistable when the Sync Gate is present. In the set state, the output of Bistable 192 output enables AND Gate 190. Therefore, the first output pulse from the Full Wave Rectifier 188 is coupled through AND Gate 190 back to Bistable 192 and resets this bistable element. Consequently, AND Gate 190 is disabled, and the second pulse from the Full Wave Rectifier 188 is not coupled through AND Gate 190. The actions of the two AND Gates, 156 and 190, serve to detect the initial time of occurrence of the last four bits in the 7-bit Fine-Sync code word.

The output of Bistable 192 is also coupled to a Remote Bit clock 194 and a Shift Monostable 196. While in the set state the output of Bistable 192 gates off the Remote Bit Clock 194. However, at the transition time which occurs at the beginning of the fourth bit in the code word, Bistable 192 is reset. At this time, the output of Bistable 192 gates on the Remote Bit Clock 194, whose output signal is coupled to the 4-Bit Shift Register 186. Simultaneously, the Shift Monostable 196 is initiated from the output of Bistable 192. The output of Shift Monostable 196 enables the 4-Bit Shift Register 186 and permits the remaining four bits of the code word to be clocked into the 4-Bit Shift Register 186. These four bits consist of the two logical ones followed by the two logical zeros, which are coupled to the 4-Bit Shift Register 186 from the output of Data Shaper 182.

The input four bits to the 4-Bit Shift Register 186 are compared with a stored Sync word. The logic circuitry utilized in this comparison consists of a set of four Inverters, 198, 200, 202 and 204 and AND Gates 206 and 158. AND Gates 206 and 158 are enabled by the output of the Sync Window Monostable 154. When the contents of 4-Bit Shift Register 186 compare on a bit by bit basis with the stored code word, a pulse is output through AND Gate 206. This output pulse represents the fact that Fine-Sync has been detected and time T_0 is established. The output pulse also represents the fact that the proper data sense has been detected in that the correct 0° phase relationship exists for the reference carrier to Phase Detector 178. On the other hand, when the contents of 4-Bit Shift Register 186 compare on a bit by bit basis with the logical compliment of the stored code word, a pulse is output through AND Gate 158. This output pulse also represents the fact that Fine-Sync has been detected, and the time T_0 is established. However, this output pulse represents the fact

that an opposite data sense has been detected in that a 180° phase relationship exists for the reference carrier to Phase Detector 178.

The outputs of AND Gates 206 and 158 are both coupled to an OR Gate 208. Thus, the output of OR Gate 208 represents Fine-Sync detection and establishes T_0 . The output of OR Gate 208 is coupled to the Logic section 130 and is utilized for resetting a Remote Master Counter 210 (FIG. 7). OR Gate 208 is also coupled to a Frequency Divider 212. This circuit divides the output of a Remote Crystal-controlled 180 kHz Clock 214 by 150, and produces the Remote Bit Clock rate at 1,200 Hz. The input to Frequency Divider 212 from OR Gate 208 reestablishes the correct phase of the Remote Bit Clock pulses once each communication cycle. These pulses are coupled to the Logic section 130 as Remote Bit Clock pulses.

The output of the Frequency Divider 212 is also coupled to and synchronizes an 1,800 Hz Carrier Oscillator 213. The output of Carrier Oscillator 213 is coupled to a Response Modulator 226. The Response Modulator 226 produces Pulse Amplitude Modulation of the carrier input according to the binary input response data stream. The modulated carrier output is amplified in Amplifier 136. The impedance of the output of Amplifier 136 is adjusted appropriately for transmission of the modulated carrier through the Relay 138 and through the Isolation Transformer 132 to the attached communication line.

The outputs of AND Gates 206 and 158 are coupled separately to a Bistable 216. If there is a pulse from AND Gate 206, Bistable 216 is set. If there is a pulse from AND Gate 158, Bistable 216 is reset. In the set state, the Q output of Bistable 216 enables an AND Gate 218 and the data stream from the Data Shaper 182 is coupled directly to an OR Gate 220. In the reset state, the output \bar{Q} of Bistable 216 enables an AND Gate 222, and the data stream from the Data Shaper 182 is inverted in an Inverter 224 before being coupled through AND Gate 222 to OR Gate 220. Therefore, Bistable 216, AND Gates 222 and 218, and Inverter 224 function such that the correct, positive data sense for the data bit stream is always coupled to OR gate 220. The data stream from OR Gate 220 is coupled to the Logic section 130 for further processing.

Coarse and Fine Synchronization have been detected and a stable carrier reference for subsequent command data demodulation has been established. An example of remote Logic Circuitry 130 is shown in block form in FIG. 7. The Logic section 130 demultiplexes the appropriate input command data which correspond uniquely to each particular Remote Transceiver 26. Subsequently, these data may be processed and utilized for remote control of an attached Traffic Control Device 20. The Logic section 130 also multiplexes response signals into a predetermined time interval and couples this information to the Response Modulator 226 (FIG. 6). A response signal may correspond to the existent state of an attached Traffic Control Device 20, or Vehicle Detector 30, or an emergency Vehicle Locator 32.

The output Sync pulse from OR Gate 208 in the Data Receiver Section 126 of FIG. 6 is coupled through a Reset Pulse Shaper 228 to the Remote Master Counter 210 as shown in FIG. 7. This pulse resets the Remote Master Counter 210 to zero, corresponding to time T_0 . The output Bit Clock pulses from the Data Receiver

section are coupled through a Bit Clock Pulse Shaper 230 to the Remote Master Counter 210. These Bit Clock pulses are also coupled to a Clock Pulse Delay circuit 232 and to a Data Sample Pulse Generator 234.

For the circuitry of the preferred embodiment under discussion, each Remote Terminal 24 is assigned a particular time interval for reception of command data. The beginning of this time interval for any given Remote Terminal may be designated, for instance, as X counts after T_0 . In addition, each set of commands to each remote unit may be comprised, for instance, of two, three, four, or five bits. The particular number of bits, n , contained in a command to a given Remote Terminal 24 depends on the required number of different functions which the given Remote Terminal must perform. For instance, in a received command, the first bit may be utilized to designate the Remote or Local Control Mode, being a binary one for Remote Control or a binary zero for Local Control. The remaining one, two, three, or four bits in the command to a given Remote Terminal can be utilized, respectively, to describe two, four, eight, or 16 different commands.

The Remote Master Counter 210 outputs a pulse at X counts and sets a Bistable 236. In the set state, Bistable 236 enables a Command Decode Counter 238. The input Bit Clock pulses also are coupled to the Clock Pulse Delay circuit 232 which delays input Bit Clock pulses by a small amount of time, for instance, 10 microseconds. This delay enables the same count X to be counted as the first count in the Command Decode Counter 238. When enabled by the output of Bistable 236, the Command Decode Counter 238 counts the delayed input clock pulses. At the time of the delayed first input clock pulse to the Command Decode Counter 238, an output gate is generated by the Command Decode Counter circuit and is coupled separately to an AND Gate 240. This output gate is approximately one bit time in extent and is labeled as Count 1 into AND Gate 240 in FIG. 7. Subsequently, when the next bit clock pulse is input to the Command Decode Counter 238, corresponding to $n=2$, the previously output gate to AND Gate 240 is terminated, and another similar gate is separately coupled to an AND Gate 242. This procedure is repeated up to and including the n th gate to AND Gate n . These gates are enabling gates for the respective AND Gates 240 through n . If a given remote unit requires 5 bits in its command, then $n=5$, and there will exist five AND Gates.

The Command Decode Counter 238 also accumulates counts to the $n+1$ count, at which time a pulse is coupled to and resets Bistable 236. As Bistable 236 is reset, the output thereof resets the Command Decode Counter 238 to zero and disables the circuit.

The clock pulses from the Bit Clock Pulse Shaper 230 are also coupled to the Data Sample Pulse Generator 234 which delays each clock pulse by approximately one-half bit time and couples the pulses in parallel to AND Gates 240 through n . Therefore, AND Gate 240, when it is enabled, couples the corresponding delayed pulse from the Data Sample Pulse Generator 234 to a Bistable Latch circuit 244. Subsequently, AND gate 242, when it is enabled, couples the correspondingly delayed pulse from the Data Sample Pulse Generator 234 to Bistable Latch circuit 246, etc. These input pulses to Bistable Latches 244 through n are uti-

lized to enable the latches. Each latch circuit is enabled sequentially for approximately one-half bit time.

The detected data stream from OR gate 220 in the Data Receiver section is coupled in parallel to the Bistable Latches 244 through n . Therefore, during the enabled interval of each latch, the respective latch will assume the state of the input data bit which exists in the data stream at that particular time. In this manner, the serial stream of data bits is converted to a parallel digital word for use as a command, for instance, to an attached Traffic Control Device 20. The Bistable Latches 244 through n may be connected separately to Interface Equipment 28 for actual control of on-the-street traffic lamp indicators or Traffic Control Devices 20.

The response time interval for any given remote unit can be determined, for example, in the following manner. At the Central Facility 10, the total response time for all attached remote units on a single communication line may be designated as the interval from count 2301 to count 7251, as shown previously in FIG. 2. This count difference is 4,950 counts. This count interval may be divided, for instance, into 150 equal and discrete response time intervals. Therefore, each discrete interval would be 33 counts in extent, representing approximately 9.2 milliseconds in time, based on the 3,600 Hz count rate at the Central Facility 10. These procedures permit a total of 150 remote units to be coupled to one communication line.

The particular discrete response time interval of 9.2 milliseconds permits each Remote Transceiver 26 to transmit a response signal with a maximum bit length of five bits. Therefore, for an assumed bit rate of 1,200 Hz, a maximum length response signal occupies about 4.2 milliseconds in time. This provides about 5 milliseconds of additional time for transmission delays to and from any remote unit. A maximum one-way transmission delay of 2.5 milliseconds corresponds to a 25 mile distance at an assumed 10^4 miles/second communication line transmission speed. Other procedures could be utilized to increase the total number of attached remote units. For instance, the bit rate could be increased. On the other hand, particular compensation for transmission delays could be applied, such that the discrete response time intervals could be decreased. However, in the circuitry of the preferred embodiment, the simplest procedures have been followed to facilitate description of the basic concepts of the invention in the clearest possible manner. This has also been done in order to allow maximum flexibility for the insertion or changing of any remote unit and in order to permit installations to be made at any arbitrary distance from the Central Facility 10.

In FIG. 2, command data from the Central Facility 10 are initiated at count 51, which would be equivalent to T_0 in a Remote Transceiver which experienced zero transmission delay time. However, a maximum one-way transmission delay of 2.5 milliseconds is assumed for each Remote Transceiver. Consequently, the observed T_0 time in any given Remote Transceiver is assumed to have been delayed by 2.5 milliseconds. Since the response time in any given Remote Transceiver is determined by counting a given number of counts after T_0 , the initiation of this response time in a Remote Transceiver must also be assumed to have been delayed 2.5 milliseconds. Therefore, the actual response time interval available at any given Remote Transceiver is

approximately 6.7 milliseconds, which is obtained by subtraction of 2.5 milliseconds from the total discrete time interval of 9.2 milliseconds.

In any given Remote Transceiver, if the response signal transmission is initiated at Y counts after T_0 , there will remain 6.7 milliseconds for transmission of the particular response signal back to the Central Facility 10. If a maximum bit response signal of five bits is assumed for each remote unit, this five bit response signal will require about 4.2 milliseconds at a bit rate of 1,200 Hz. Thus, there will remain about 2.5 milliseconds for transmission of this particular response signal back to the Central Facility 10, before another response signal from some other Remote Terminal is to be received at the Central Facility.

The initiation of the particular response interval allotted to any given remote unit is actually determined by the $Y-1$ count output from the Remote Master Counter 210, instead of the Y count. This procedure allows adequate time for transmission circuitry stabilization, prior to actual transmission of the response signals.

In FIG. 7, the $Y-1$ count output from the Remote Master Counter 210 is coupled to and sets a Bistable 248. When in the set state, Bistable 248 enables a Response Counter 250. The output of Bistable 248 is also coupled to the transmission Relay circuit 138, shown in FIG. 6, which permits coupling of the Amplifier 136 through the Isolation Transformer 132 to the Communication line, which may be Communication Link 22, for example.

The function of the Response Counter 250 is analogous to that described above for the Command Decode Counter 238. When enabled from Bistable 248, the Response Counter 250 accepts delayed Bit Clock pulses from the Clock Pulse Delay circuit 232 and outputs corresponding and separate gates which are 1 bit time in extent. It is noted that the first output gate occurs at the time of the second input bit clock pulse to the Response Counter 250. This gate is coupled separately to a Response AND Gate 252 and is labeled as Count 2. Subsequently, the third input clock pulse to the Response Counter 250 initiates generation of the second gate which is coupled separately to a Response AND gate 254. The $n+1$ clock pulse initiates generation of the n th gate in the Response Counter 250, and this gate is separately coupled to Response AND Gate n . If five bits are required in the command signal to a given remote unit, the response signal must also contain five bits, and there would thus exist five Response AND Gates in the response circuitry.

Each of the gate outputs from the Response Counter 250 are enabling gates. Since these gates occur sequentially, each Response AND Gate is enabled in a sequential manner. The response signal data are also coupled separately to the Response AND Gates. These data are in binary form. At any given time, each response data bit to each Response AND Gate will be a binary zero or one, dependent on the particular response signal to be transmitted back to the Central Facility 10. The first binary bit input to Response AND Gate 252 will be coupled to OR Gate 256 when Response AND Gate 252 is enabled. Similarly, the remaining data bits are serially coupled to OR Gate 256. Therefore, the output of OR Gate 256 is a serial data stream representing the response signal to be transmitted.

As mentioned previously, the response data signals may be representative of the existent state of attached Traffic Control Devices 20, Vehicle Detectors 30, or Emergency Vehicle Locators 32. All of the above response signals may be present at a particular Remote Terminal. In such a case, three Remote Transceiver units 26 could be utilized, one for each type of response signal. On the other hand, circuit modifications could be implemented in a Remote Transceiver 26 such that the discrete time interval allotted could be expanded to include the additional types of response signals. These response signals are discussed further hereinafter.

V. DESCRIPTION OF THE PREFERRED INTERFACE EQUIPMENT FOR COMMAND EXECUTION FOR THE COMMUNICATION LINK SYSTEM

A variety of interface equipment could be utilized for coupling the Computer 12 to the Master Transceiver 16 and for coupling local Traffic Control Devices 20 to Remote Transceivers 26. With respect to coupling information to and from a digital computer, the use of input and output storage registers for binary data is the simplest method. Thus, response data from all Remote Transceivers 26 may be accumulated in an output storage register contained, for instance, in Interface Equipment 14. This register may be dumped once each communication cycle into an input port or channel of the digital computer facility. In a similar manner, output commands generated by the computer software package can be dumped once each communication cycle into an input storage register contained, for instance, in Interface Equipment 14, for subsequent readout by the Multiplexer 58 in the Logic section 56 of the Master Transceiver 16. These procedures will enable the attached on-line, real-time computer facility to be utilized in an efficient manner. For instance, in a time-sharing computer facility, many other functions, calculations, etc. can be maintained, together with the Traffic Transporation Control Function.

For Interface Equipment 28 which might be coupled to a Remote Transceiver 26, preferred circuitry will be described which is simple in function and relatively inexpensive in cost. There are a number of different types of electromechanical and solid state devices which may be utilized for the local control of traffic lamp indicators at any given street intersection. Such devices are called local Controllers. Thus, a Local Controller is a device which energizes different traffic lamp indicators at a street intersection according to some prearranged input program. An input program may consist of appropriate input signals from some master controller facility, or the input signals may be internally generated with in the Local Controller circuitry. In some cases, these input programs may be altered to some extent by auxiliary inputs from nearby Vehicle Detectors 30.

For the simplest configuration of the disclosed System, a Local Controller device is assumed operative at each intersection for which a remote control function is desired. Transfer of commands to appropriate lamp circuits can be accomplished by simple interface equipment between the Remote Transceiver 26 and the Local Controller device. A complex intersection problem of three through-streets will be assumed, and ex-

ample circuitry will be discussed which is applicable to such an intersection. More simple intersection problems can be treated with more simple interface circuitry, as will be discussed subsequently.

In general, a six street intersection (three through-streets) will require 5-bit commands to satisfy all necessary traffic functions. The commands may be stored once each communication cycle in five Bistable Latches, 244, 246, $n-2$, $n-1$, n as previously discussed in reference to FIG. 7. The outputs of these Bistable Latches may be coupled separately to five Bistable circuits 258, 260, $n-21$, n as shown in FIG. 8. The Bistable outputs may be coupled to a Logic circuit 262, which can be utilized to specify the mode of control for the attached Local Controller, either Remote or Local control. The outputs of Bistables 260 through n represent a particular input command at any given time, and these outputs may be coupled separately to a Logic circuit 264.

As an example, Logic circuit 262 may comprise circuit functions as shown in FIG. 9. An input voltage to Bistable 258 represents a binary one for the first bit in a command and further represents a Response Monitor function. That is, if all command bits to Bistables 260 through n have zero values, Logic 262 circuitry will not change the attached Local Controller from the Local Control Mode. However, appropriate data representing the existent states of the traffic lamp indicators will be transmitted back to the Central facility 10. Therefore, the Local Controller functions can be remotely monitored. These response signals will be discussed subsequently in relation to FIG. 14.

The output of Bistable 258 is coupled to AND gate 270. The outputs of Bistables 260 and $n-2$ are coupled to OR gate 271. The outputs of Bistables $n-1$ and n are coupled to OR gate 273. The outputs of OR gates 271 and 273 are coupled to OR gate 274. The output of OR gate 274 is coupled to and utilized as an enabling gate for AND gate 270. Therefore, when there is an output from Bistable 258 to AND gate 270, and when at least one command bit is present from any one of Bistables 260 through n , AND gate 270 will be enabled. The output of AND gate 270 is coupled to AND gate 266. An enabling gate to AND gate 266 may be provided from any particular traffic lamp indicator circuit desired. For the present discussion, it is assumed that the local Control Mode can be interrupted at the Amber phase of the No. 1 street. Therefore, a portion of the AC power to the No. 1 Amber lights 272 may be coupled over line 281 to Diode 279. The half wave rectified output of Diode 279 may be used as an enabling gate to AND gate 266.

The output of AND gate 266 is coupled to and sets Bistable 276. In the set state, Bistable 276 output activates Relay 268. AC power for sequencing or stepping of the different phases of the attached Local Controller is removed by means of Relay contacts 280 and transferred to line 282. Line 282 then couples AC power for the traffic lamp indicator circuits for the Remote Control Mode.

At any subsequent time, if all command bit values are made zero, the output of OR gate 274 will be eliminated. The output of OR gate 274 is also coupled to Flip Flop 277. This Flip Flop 277 can be arranged such that, with zero input, an output pulse may be coupled to Diode 285 and to Delay Monostable 278. The output of Diode 285 is coupled via line 283 to the Amber line

inputs No. 1, No. 2, and No. 3. This output from Diode 285 will cause the appropriate Amber lamps to be illuminated, as will be described subsequently. Delay Monostable 278 may be adjusted to output a delayed pulse to reset Bistable 276. In the reset state, Bistable 276 output releases Relay 268, and the Local Control Mode is reestablished. An appropriate delay time for Delay Monostable 278 would be 4 or 5 seconds.

Logic circuitry 262 permits a safe and appropriate change from any traffic signal phase under the Remote Control Mode back to the original Amber phase of the Local Control Mode.

Logic circuit 264 indicated in FIG. 8 may comprise a 4-input to 16-output Decoder Logic circuit, similar to those commercially available. Such a logic circuit accepts binary data, a zero or one bit input on four separate channels. Dependent on the particular set of input data, one unique output line, out of a possible 16 lines, will be activated. Simple circuitry comprising diodes and resistors also can be utilized to accomplish the same function as logic circuit 264.

In an electromechanical type Controller, there exists a series of motor-driven cams which independently operate a series of cam switches which, in turn, apply AC power to particular lamp indicators under the local Control Mode. If the locally controlled traffic cycle is interrupted when the Amber lamps 272 for the first Street are illuminated, the associated cam switches for this type of Local Controller are closed for this No. 1 Amber circuit. In addition, the Red Lamp indicators for a second and third Streets will be illuminated, and the associated cam switches will be closed. All other cam switches will be open at this time, except perhaps any associated pedestrian DON'T WALK signals. It is noted that some municipalities may require that the Green lamp indicators remain illuminated when the associated Amber lamp indicators are illuminated. This latter circumstance has not been assumed in the particular circuitry described herein. However, simple circuit changes can be made to permit the Green lamp indicators to remain illuminated when the associated Amber light indicators are illuminated, and will be discussed subsequently.

Other types of Local Controllers such as devices constructed from solid state components may not utilize cam operated lamp switches. However, there will exist a sequencing function which can be interrupted similar to that discussed for Relay 268 in FIG. 9. Also at any given time of interrupt, there will be some lines to traffic lamp circuits which will have AC power applied and other lines to traffic lamp circuits which will not have AC power applied. Therefore, for such Local Controller types, the following circuit discussions will be applicable.

An Example circuit for remote control of a six-street intersection is shown in FIG. 10. The total circuit will not be described in detail since the traffic control functions are similar for the different streets. In addition, it is noted that many other traffic control functions might be included by appropriate changes or additions to the circuitry shown. For the circuitry shown in FIG. 10, there are 13 different input commands which have been considered. For each of the three through-streets, these commands are represented as Green, Left Turn Green, Amber, and Emergency. In addition, a DON'T WALK Interrupt Command is included to enable appropriate DON'T WALK signals prior to initiation of

any Amber signal. This function is included so that any pedestrian traffic may have ample time for street clearance, before a subsequent Green or Left Turn Green Command is issued. Also, in FIG. 10, the cam Operated Switches mentioned previously have been indicated symbolically. For interruption of the locally controlled function at the time of illumination of No. 1 Amber lights, a line 284, which comprises all currently active lamp circuits, will have AC power always applied from the attached Local Controller in the Remote Control Mode. A Line 286, which comprises all currently inactive lamp circuits, will not have any AC power applied from the associated cam switches.

In FIG. 10, there is indicated to be a relay circuit attached to each separate type of lamp indicator, dependent on the desired functions. For instance, for street No. 1, Left Turn Green Signals are assumed to be desired for both street directions. Consequently, both Red lamps for both directions will remain illuminated throughout the illumination time of these Left Turn Green signals and the corresponding Green lamps for both directions of this street will not be illuminated. For instance, for Street No. 2, a Left Turn Green signal is assumed only for direction 1 of this street. For street No. 3, a Left Turn Green signal is assumed only for direction 2 of this street. Right turn indicators could be added as they are required, since such functions are usually coincident with the appropriate Left Turn Green signals. The circuitry also may be adapted to permit Left Turn or Right Turn Green signals at the beginning of the associated Green cycle time or at the end of the associated Green cycle time.

Also indicated in FIG. 10 are 21 Response Boxes 288 through 328. These Response Boxes simply represent the individual outputs from the associated lamp circuits. These will be discussed subsequently when the response interface equipment is described.

As is indicated in FIG. 10, the main AC power from Logic circuit 262 is coupled via line 282, through the contacts 330 of a Relay 446 to a line 332. AC power is input to a line 334 only if No. 1 Green is not active. Therefore, No. 2 or No. 3 Green, including their respective Left Turn Greens cannot be activated if No. 1 Green is active. In addition, AC power is supplied to a line 336 only if both No. 1 Green and No. 2 Green are inactive.

As an illustration of the circuit functions shown in FIG. 10, a lamp indicator cycle for Street No. 2 will be discussed. The lamp indicator cycles for Streets No. 1 and No. 3 are similar or identical. The pertinent elements for Street No. 2 lamp indicators are shown in FIG. 1 for a normal traffic control cycle of this street.

When the locally controlled traffic function is interrupted for Remote Control, Street No. 1 Amber lights 272 are illuminated, and R lamp indicators 374 and 372 for Street No. 2 are illuminated as depicted in FIG. 11. Since No. 1 Amber lights 272 are illuminated, the initial input command from the Central Facility 10 will be the No. 1 Amber Command. Initiation of this command will not cause any circuit responses, since the No. 1 Amber lamps are initially illuminated. When the Amber lights are illuminated for a particular street, a portion of their AC voltage is rectified and coupled separately to flip-flop circuits for the remaining streets. In FIG. 11, a portion of the No. 1 Amber light 272 AC voltage is rectified in a group of diodes 342 and coupled to flip-flop circuits 344 and 346 on a line 348 for

Street No. 2, and to flip-flop 350 and 352 on a line 347 for Street No. 3. These rectified AC voltages activate the respective flip-flop circuits which output enabling gates to the attached AND Gates. In addition, the flip-flops may be arranged such that their output enabling gates will persist for a few milliseconds after the input rectified AC voltage is removed.

In FIG. 11, flip-flops 344 and 346 are activated from the No. 1 Amber lamp circuit and AND gates 356 and 358 are enabled. Therefore, either a No. 2 Green or a No. 2 left Turn Green Command could be applied to Street No. 2. A similar situation exists for Street No. 3. For discussion purposes, it is assumed that the No. 2 Left Turn Green command is applied subsequent to removal of the initial No. 1 Amber Command. If a positive voltage is utilized to activate the No. 1 Amber Line, when the No. 1 Amber Command is terminated, this positive voltage will be removed. The resultant differentiated negative pulse can be coupled from the No. 1 Amber Line to a Bistable 360 and used to set the Bistable. In the set state, Bistable 360 activates a Relay 362 and AC power from line 284 is removed from the No. 1 Amber lights. The differentiated negative pulse input to Bistable 360 is also coupled to a Bistable 364, and sets this Bistable. In the set state, Bistable 364 activates a Relay 366 and couples AC power to the R lamp indicators 338 and 340 for Street No. 1.

At the same time that the No. 1 Amber Command is terminated, the No. 2 Left Turn Command occurs, and the No. 2 Left Turn Green line is energized. Since AND Gate 358 remains enabled for a short period of time, the positive voltage on No. 2 Left Turn Green line is coupled to and sets a Bistable 368. In the set state, Bistable 368 activates a Relay 370 and applies AC power through one set of contacts of Relay 370 to an R lamp indicator 372 for direction 2 of Street No. 2. It is noted that both R lamp indicators for Street No. 2, 372 and 374, are currently illuminated through contacts of a Relay 376 to line 284. This additional coupling of AC power to the R. lamp indicator 372 for Street No. 2 will prevent possible blinking of this lamp indicator as execution of the No. 2 Left Turn Green Command is completed.

When Relay 370 is activated, a portion of the AC voltage from one of the Relay 370 contacts is rectified by a diode 378 and coupled to a Bistable 380. This voltage sets Bistable 380 and activates Relay 382. Through the contacts of this relay, AC power is coupled to a G lamp indicator 384 for Street No. 2. AC power also is coupled from the other contacts of Relay 382 through one set of contacts of Relay 370 to an LG lamp indicator 386 for Street No. 2. In addition, the input to Bistable 380 from Diode 378 is coupled to a Bistable 388 and through a diode to a Bistable 420. This applied voltage sets Bistable 388. In the set state, Bistable 388 activates Relay 376 and AC power from line 284 is removed to the R lamp indicator 374 for Street No. 2. The R lamp indicator 372 remains illuminated as discussed in the previous paragraph. The applied voltage through the diode to Bistable 420 resets this Bistable. In the reset state, Relay 428 is released and the DON'T WALK lamp circuit for No. 2 street is activated, if these signals are present at the intersection. A pair of R lamp indicators 390 and 392 for Street No. 3 remain illuminated, as was their initial state, from AC power coupled from line 284 and the associated relay as shown in FIG. 10. Thus, No. 2 Left Turn Green Com-

mand has been executed. The R lamp indicators for Streets No. 1 and No. 3, 338,340,390, and 392 are illuminated, and LG 386, G 384, and R 372, lamp indicators for Street No. 2 are illuminated. This circumstance will persist until the No. 2 Left Turn Green Command is removed.

When No. 2 Left Turn Green Command is terminated, the positive voltage on the No. 2 Left Turn Green line is removed. The resultant differentiated negative pulse on this line is coupled to and resets Bistable 368. In the reset state, Bistable 368 releases Relay 370 and AC power is transferred from LG lamp indicator 386 to G lamp indicator 394 for Street No. 2. AC power is also removed from R lamp indicator 372 for Street No. 2. The next sequential command is No. 2 Green Command. In this instance, the No. 2 Street G lamp indicator 384 and a G lamp indicator 394 are already illuminated. If the No. 2 Left Turn Green Command had been skipped, activation of the No. 2 Green line would have coupled a positive voltage through AND Gate 356 to Bistables 380, 388 and 420. The coupling through AND Gate 356 would have been permitted since flip-flop 344 would have been activated from the previous Amber lamp illumination from either Streets No. 1 or No. 3. In the present instance, activation of the No. 2 Green line, which occurs as a consequence of detection and processing of the No. 2 Green Command in Logic 264, FIG. 8, does not cause any other circuit response. When the G lamp indicator 394 is illuminated, AC voltage in the form of positive pulses are coupled through a diode 396 to a Flip-Flop 398. Thus, Flip-Flop 398 is activated and enables an AND Gate 400 for subsequent usage. For instance, when No. 2 Green Command is terminated, positive voltage is removed from the No. 2 Green line. The resultant differentiated negative pulse from differentiator 357 is coupled and resets Bistable 380. In the reset state, Bistable 380 releases Relay 382, and AC power is removed from the G lamp indicators 384 and 394 for Street No. 2.

The next sequential command is No. 2 Amber Command. When this command is detected and processed in logic 264, FIG. 8, a positive voltage may be applied to the No. 2 Amber line. This positive voltage is coupled through the enabled AND Gate 400 to a Bistable 402. Bistable 402 is set and in this state activates a Relay 404, which couples AC power to No. 2 Amber lamp indicators. When No. 2 Amber signals are illuminated, AC voltage in the form of positive pulses is coupled through a pair of diodes 406 to a pair of lines 347 and 349. Line 349 separately couples to a Flip-Flop 412 and a Flip-Flop 414 for Street No. 1, and line 347 separately couples to Flip-Flop 350 and Flip-Flop 352 for Street No. 3. Therefore, at the termination of No. 2 Amber Command, either Street No. 1 traffic control functions may be initiated, or Street No. 3 traffic control functions may be initiated.

If DON'T WALK signals are utilized at an intersection, these signals are usually activated prior to the initiation of any given Amber lamp time. This is done so that the intersection may be cleared of any pedestrian traffic, prior to the issuance of a subsequent command. In addition, it is noted that no two commands can be present on the input lines at the same time. Therefore, if a DON'T WALK Interrupt Command is issued, the currently active line containing a Green Command must be terminated. However, continued illumination of the particular activated Green lamps must be main-

tained. This may be accomplished by eliminating the differentiator circuits 411, 357 and 477 attached to each Green Command input line. Therefore, when any particular Green Command is terminated the Corresponding G lamp indicators will remain illuminated. Subsequently, when the associated Amber Command is initiated, one of two situations can be implemented. If it is desired that the presently active G lamps remain illuminated throughout the associated Amber lamp time, then the connections indicated by the dashed lines 408, FIGS. 10 and 11, can be made. These lines 408, couple the differentiated pulses from the input Amber lines to the reset terminals of the associated Green Command Bistables. Therefore, a particular activated G lamp circuit will not be de-activated until the subsequent and associated Amber Command is terminated. On the other hand, if it is desired to terminate illumination of the G lamp indicators when the associated Amber Command is initiated, the connections indicated by the dashed lines 410, FIGS. 10 and 11 can be made. These lines, 410 couple a portion of the rectified AC voltage of the illuminated Amber lamps to the reset terminal of the associated Green Command Bistables.

The DON'T WALK signal function can be accomplished in the following manner. The DON'T WALK Interrupt Command line is coupled directly to line 424, FIGS. 10 and 11. The differentiator circuits 411, 357 and 477 are eliminated as previously mentioned. Then either the lines 408 or 410 are connected. Subsequently, when the DON'T WALK Interrupt Command line is activated, this line voltage is coupled separately through diodes from line 424 to the reset terminals of Bistables 418, 420 and 422. In the reset state, these Bistables respectively release relays 426, 428, and 430 and apply AC power from line 284 through the respective relay contacts to all DON'T WALK lamp indicators. This circumstance maintains throughout the subsequent Amber lamp command. The WALK lamp indicators for a given street are illuminated when the associated R lamp indicators for both directions of the street are activated.

The Emergency Control Commands constitute a unique feature of the interface circuitry under discussion. The essential elements of this part of the circuitry are shown in FIG. 12. The purpose of emergency commands is to facilitate emergency vehicle flow through intersections. The procedure to be described would be particularly useful for emergency vehicle travel on through-streets in congested areas. The scheme permits interruption of the usual traffic signal cycle at any intersection under remote control, and imposes emergency vehicle controls. For instance, if an emergency vehicle is proceeding along Street No. 1 through an intersection, the Street No. 1 Green Lights may be placed in the state of Rapid Flashing Green, while the lights for intersecting streets No. 2 and No. 3 may be placed in the state of Rapid Flashing Red. Alternatively, an emergency vehicle may be proceeding along Street No. 2 or No. 3. In either of these cases, Rapid Flashing Green could be imposed on the street containing the emergency vehicle, and Rapid Flashing Red could be imposed on intersecting streets.

Other emergency vehicle procedures could be utilized. For instance, all traffic lights at an intersection might be placed in the state of Rapid Flashing Red.

However, such a procedure usually will not result in rapid clearance of the intersection.

It is possible to permit an emergency vehicle interrupt command at any time during any part of the traffic signal cycle. However, the simplest procedure would permit an emergency command only during the Green or Amber time interval for one of the streets at an intersection. Therefore, if a Left Turn Green Command existed at the time desired for an emergency vehicle interrupt, the actual Emergency Command can be delayed or not transmitted from the Central Facility 10 until a subsequent Green Command has been issued. This procedure permits the use of simple circuitry for the Emergency Commands. In any case, the maximum delay which would be experienced at any intersection would amount to only a few seconds. The issuance of an Emergency Command during a Green or Amber time can be controlled easily by the software package of the Central Facility computer equipment.

With reference to FIG. 12, assume that an emergency command is to be issued for one of the Streets, No. 1, No. 2 or No. 3. Detection and processing of the particular Emergency Command in Logic 264 of FIG. 8 will apply a positive voltage to one of the Emergency Lines No. 1, or No. 2, or No. 3, in FIG. 12. This voltage is differentiated and a positive pulse is coupled from whichever Emergency line is activated to all Amber input lines No. 1, No. 2 and No. 3 via line 283. From previous discussions it is noted that whenever a particular Green Command is active, the associated Amber Line AND Gate for that street is also enabled. Therefore, when any one Emergency Line is activated, the coupled positive voltage pulse to all Amber lines will, of necessity, activate one and only one of the Amber lamp circuits. The particular Amber lamp circuit which is activated will be that one which corresponds to the same street with the active Green Command.

Assume No. 1 Emergency Command is issued in FIG. 12, when the No. 2 Green Command is active. Coupling of the positive voltage pulse from No. 1 Emergency line via line 283 to the respective Amber lines No. 1, No. 2 and No. 3 will activate the No. 2 Amber lamp circuit. As described previously, the usual circuit functions will occur.

All Emergency lines are also coupled through diodes to line 447, which is coupled to Delay Monostable 444. This monostable may be arranged to output a pulse which is delayed by several seconds, say 4 seconds, which represents the time for the Amber light interval. The delay pulse output from Delay Monostable 444 sets Bistable 442. In a set state, Bistable 442 activates a Relay 446. In addition, the output of Delay Monostable 444 is coupled via line 351 to the set terminal of No. 1 Amber Bistable 360 and to the reset terminals of No. 2 Amber Bistable 402 and No. 3 Amber Bistable 478. Therefore, when the No. 1 Emergency line is activated, as mentioned above, the No. 2 Amber lamp circuit will be activated for 4 seconds, at which time the No. 2 Amber Bistable 402 will be reset. In a reset state, Bistable output causes deactivation of the No. 2 Amber lamps. When Relay 446 is activated, AC power on line 282 is transferred by means of contacts 330 of Relay 446 to a Rapid Flasher 456. The Rapid Flasher output is coupled back to line 332 and supplies rapid bursts of AC power to line 332. In addition, a second output from Bistable 442 is used to enable AND Gates 448, 450 and 452. In the present instance, No. 1 Emergency

line is activated and this voltage is coupled through AND Gate 448 to the set terminal of the No. 1 Green Command Bistable. Therefore, the No. 1 Green Command function is executed, with the exception that all lamp circuit power is now in the rapid flashing mode. Thus, for the No. 1 Emergency Command, a pair of G lamp indicators 458 and 460 for Street No. 1 and R lamp indicators 374, 372 and 390, 392 for Streets No. 2 and No. 3 will continually flash on and off. If No. 2 Emergency Command had been issued, G lamp indicators 384 and 394 for Street No. 2 and R lamp indicators 338, 340 and 390, 392 for Streets No. 1 and No. 3 would continually flash on and off. The No. 3 Emergency Command causes a corresponding rapid flashing for a pair of G lamp indicators 462 and 464 for Street No. 3, and for R lamp indicators 338, 340 and 374, 372 for Streets No. 1 and No. 2.

In the event that DON'T WALK signals are utilized, the input line to Delay Monostable 444 may be coupled through a diode to the DON'T WALK Interrupt line, as shown in FIG. 12.

Differentiator 441 is coupled to line 447 so that, when an Emergency Command is terminated, a negative pulse is output from Differentiator 441 to Flip-Flop 455. This Flip-Flop 455 may be adjusted to immediately output a positive pulse of, say, four seconds duration. This output pulse is coupled to all input Amber lines via line 283. Therefore, the appropriate Amber lamp circuit will be activated for a 4 second period. In the present instance, after termination of the No. 1 Emergency Command, the No. 1 Amber circuit will be activated for 4 seconds. Subsequently, commands to No. 2 or No. 3 streets are possible.

If a communication link failure were to occur while in the Remote Control Mode, any possible command might be currently active. Therefore, it is necessary to progress in a safe manner from the interruption of the Remote Control Mode back to the Local Control Mode. This can be accomplished by the resultant output pulse on line 283 from diode 285, FIG. 9. If failure occurs during a No. 2 or No. 3 street Green or Left Turn Command, the associated Amber line AND Gate will be enabled. Therefore, the positive voltage output from diode 285 via line 283 to these Amber lines will activate the appropriate Amber circuit. Four seconds later, Delay Monostable 278, FIG. 9, will reset Bistable 276, and the Local Control Mode will be re-established. The same sequence will also occur for No. 1 street. If the failure occurs during the No. 1 Left Turn Command, when this command is removed due to the failure, the inverter 415, FIG. 10, will couple a pulse to the Green Command Bistable. When the G lamp indicators, 458 and 460 are illuminated, the No. 1 Amber line AND Gate will be enabled. Then circuit response is as described above for streets No. 2 and No. 3.

It should be evident that the interface equipment discussed above can be altered in a number of ways to facilitate applications of other desired functions. For example, some municipalities prefer to maintain a Green Signal illumination when the Amber signal for the same street is illuminated. This function can be attained by removal of the differentiator circuits 411, 357, and 477, and connecting the dashed lines 408, as previously discussed. In another circumstance, some municipalities may not desire to interrupt the Local Control Mode during an Amber illumination period. Corre-

sponding circuit changes can be made to accommodate these different functions.

It should be evident, also, that considerable circuit simplification is possible when the required number of functions are reduced. An example is shown in FIG. 13 for a very simple two-street intersection. It is noted that remote control of this circuit can be maintained by the use of two binary bits. Thus, the first binary bit can be utilized to designate the control mode, either Remote or Local Control. A second binary bit could be utilized to control No. 1 Street Green, for instance, by means of a zero bit value of the second binary bit in the command signal. A one value of this binary bit would then control No. 2 Street Green. Further, it is noted that the respective Amber light illuminations occur automatically when the Green Command is changed in the circuitry of FIG. 13. Finally, it is noted that elimination of all input Amber Commands could be realized for circuitry such as is shown in the previous FIG. 10. Appropriate usage of delay monostable circuits could be accomplished such that fixed Amber signal times would occur for the appropriate streets. An example of this usage of delay monostable circuits is indicated in the following circuit description for FIG. 13.

If the simple traffic functions depicted in FIG. 13 were the only requirements for all Remote Transceivers 26 attached to a single communication line, a total of 240 separate remote units or terminals could be serviced on the communication line. This total number of units includes the assumption of a 1,200 Hz bit rate and an assumed maximum one-way transmission delay of 2.5 milliseconds to reach remote unit. As mentioned previously, this total number can be increased by increasing the bit rate or by more careful compensation for possible transmission delay time.

Since only two command bits are assumed for the remote control of lamp circuits in FIG. 13, the Logic circuitry 501 will be simpler than that depicted previously in FIG. 9 for Logic 262. Specifically, all items in FIG. 9 would be eliminated except AND Gate 266, Bistable 276, Relay 368, and Diode 279. These remaining items could suffice as Logic 501 circuitry.

In operation of the circuitry shown in FIG. 13, it has been assumed that the Remote Control interrupt has occurred when the No. 2 Street Amber lights are illuminated. Therefore, a pair of R lamp indicators 482 and 484 for No. 1 Street are also illuminated by means of AC power from a line 284 through the contact of a Relay 488. The initial command would be No. 1 Green Command. For instance, when a positive voltage is applied to the No. 1 Green line, this voltage may be coupled to a Bistable 490 and to a Delay Monostable 492. Normally, this voltage would reset Bistable 490, whose output would release a Relay 494, and the No. 2 Amber lights would be illuminated. In the present instance, No. 2 Amber lights are already illuminated. When the positive voltage is applied to Delay Monostable 492, this circuit generates a delays output pulse, the delay being adjusted to whatever time interval is desired for the No. 2 Amber light illuminations. The delayed output from Delay Monostable 492 is coupled to and sets Bistable 490. In the set state, Bistable 490 activates Relay 494, and AC power from line 284 is removed from the No. 2 Amber lights. Delay Monostable 492 also is coupled to a Flip-Flop 496, whose output enables an AND Gate 498. Therefore, the No. 1 Green line voltage is coupled to and sets a Bistable 500. Ini-

tially, Bistable 500 is in the reset state. When in the set state, Bistable 500 activates a Relay 502, Relay 488, and a Relay 504. For Relay 502, AC power is applied to a pair of G lamp indicators 506, 508 for Street No. 1. For Relay 488, AC power from line 284 is removed from the R lamp indicators 482, 484 for Street No. 1. For Relay 504, AC power is applied to a pair of R lamp indicators 510 and 512 for Street No. 2. This condition maintains until the No. 1 Green Command is terminated and the No. 2 Green Command is initiated.

When the No. 2 Green line is energized, a positive voltage is coupled to a Bistable 514 and to a Delay Monostable 516. This voltage sets Bistable 514. In the set state, Bistable 514 activates a Relay 518 and AC power is applied to the No. 1 Amber lights. The voltage input to Delay Monostable 516 initiates a delayed output pulse, the delay being adjusted to that desired for the No. 1 Amber light illumination interval. The output of Delay Monostable 516 is coupled to Bistables 514 and 500 and to a Flip-Flop 520. The output of Delay Monostable 516 resets Bistables 514 and 500, releasing Relays 502, 488, 518 and 504. Therefore, AC power is removed from the G lamp indicators 506, 508 for Street No. 1. Also, AC power is coupled from line 284 to the R lamp indicators 482, 484 for Street No. 1. In addition, AC power is removed from the Amber lights of Street No. 1 and from the R lamp indicators 510, 512 for Street No. 2. Delay Monostable 516 also activates Flip-Flop 520, whose output enables an AND Gate 522. Therefore, the positive voltage on No. 2 Green line is coupled to and sets a Bistable 524. In the set state, Bistable 524 activates a Relay 526 and AC power is applied to a pair of G lamp indicators 528 and 530 for Street No. 2.

Through the use of Delay Monostables, as discussed in relation to FIG. 13, it is possible to eliminate the need for Amber lamp commands and DON'T WALK Interrupt commands. In addition, it is possible to permit locally actuated devices, such as Left Turn Vehicle Lane Detectors, to operate in parallel with a Remote Control Mode. In such a situation, the remote commands for Left Turns would not be necessary. The previously described circuits could be utilized with appropriate modifications. For instance, a local vehicle actuated Left Turn Command could preempt the associated Remote Control Green Command when this command was received at the remote unit. When vehicle actuation ceased or after a predetermined maximum length of time for the Left Turn, the Remote Control Green Command could be actuated.

Finally, it is noted that a given Green Command can be executed, delayed, or changed in time increments which are less than one communication cycle time. This function can be readily accomplished by utilizing more than one Green Command per street. For instance, three Green Commands for No. 1 street might be used as G1, G2 and G3. Each of these separate green Commands would be represented by a discrete command bit pattern. Therefore, each of these separate Green Commands would be output from Logic circuitry 264, for instance, on three separate lines. For one of the three lines, a delay of 0.6 seconds could be inserted, and for a second line a delay of 1.3 seconds could be inserted. Therefore, Green Commands could be initiated in increments of approximately 0.7 seconds, instead of the usual 2 second increments for a 2 second communication cycle time.

VI. DESCRIPTION OF PREFERRED INTERFACE EQUIPMENT FOR RESPONSE DATA FOR THE COMMUNICATION LINK SYSTEM

An illustrative example of interface circuitry which can be utilized for coupling response signals from the traffic lamp indicators at a given intersection to the associated remote unit is shown in FIG. 14. Inputs to the circuit are labeled 288 through 328. These may be obtained, for instance, as input voltage as shown in FIG. 10. The 288 through 324 inputs are connected to the different traffic lamp circuits, such that when AC power is applied to a particular lamp circuit, AC voltage is also coupled to the correspondingly numbered R input. The 326 input occurs from line 282, shown in FIGS. 9 and 10, and is representative of the Remote Control Mode. The 328 input occurs on closure of Emergency Relay 426 and is representative of the Flashing Mode for lamp indicators under Emergency Vehicle Control.

In FIG. 14, each of the inputs 288 through 324 may be coupled separately to two individual channels. One channel is input to a first Logic Network 532, and the second channel is input to a second Logic Network 534. When any particular command has been correctly executed, there will exist a discrete set of traffic lamp indicators which are not active and a second discrete set of traffic lamp indicators which are active. For any given command, the particular traffic lamp indicators belonging to each set is known. Thus, for Logic 532, a particular group of R inputs may be coupled together through OR gates to comprise the No. 1 line output from Logic 532. This group of R inputs comprises a representation of those lamp indicator circuits which should not be activated when some specific command has been correctly executed. For instance, line No. 1 output from Logic 532 could correspond to the No. 1 Green Command. Thus, the 390 through 294, 298 through 302, 308 through 316 and 322 through 324 inputs will be logically OR'd to line No. 1 output from Logic 532. Correspondingly, for this same command, the 288, 296, 304, 306, 318 and 320 inputs will be logically AND'd in Logic 534 to comprise line No. 1 output from Logic 534.

In a similar manner, the appropriate R inputs for other commands can be logically OR'd for No. 2 through No. 10 output lines from Logic 532, and other appropriate R inputs for the same corresponding commands can be logically AND'd for No. 2 through No. 10 output lines from Logic 534. For instance, line No. 2 can correspond to No. 2 Left Turn Green Command, line No. 3 to No. 1 Left Turn Green Command, line No. 4 to No. 3 Left Turn Green Command, Line No. 5 to No. 1 Amber Command, line No. 6 to No. 2 Green Command, line No. 7 to No. 3 Green Command, line No. 8 to DON'T WALK Interrupt Command, line No. 9 to No. 2 Amber Command, and line No. 10 to No. 3 Amber Command. Therefore, when any of these commands has been executed correctly, the correspondingly numbered output line from Logic 532 circuitry will not be energized and the correspondingly numbered output line from Logic 534 circuitry will be energized. The remaining three lines No. 11, No. 12 and No. 13, correspond, respectively, to No. 3 Emergency, No. 2 Emergency and No. 1 Emergency Commands.

The output lines from Logic 532 and Logic 534 may be coupled separately to a third Logic Network 536. For instance, Logic 536 may be arranged as depicted in FIG. 14. Each input line from Logic 534 can be logically OR'd in an OR Gate 538, within Logic 536. For any command which has been correctly executed, one and only one of the input lines from Logic 534 will be energized. This voltage will be coupled through OR Gate 538 to a Bistable 540. With voltage input to Bistable 540, an enabling gate is coupled to an AND Gate 542 from the output of Bistable 540. In addition, each numbered input line from Logic 534 can be coupled to and utilized to enable a correspondingly numbered AND Gate, within Logic 536. The correspondingly numbered input lines from Logic 532 can be coupled to each of the same numbered AND Gates, within Logic 536. An example of this coupling within Logic 536 is shown in FIG. 14 for an AND Gate 544 and the number 5 input lines. The outputs of all AND Gates within Logic 536 can be logically OR'd in an OR Gate 546. For any command which has been correctly executed, one and only one of the AND Gates within Logic 536 will be enabled. The particular AND Gate which is enabled will correspond to the particular executed command. Also the correspondingly numbered line output from Logic 532 which is coupled to this enabled AND Gate will not be energized. Therefore, there will be no input to OR gate 546 within Logic 536, and consequently, no output from OR Gate 546 to Bistable 548. A Bistable 548 may be arranged so that an output gate is coupled to AND Gate 542 when no input voltage is supplied to Bistable 548. Since AND Gate 542 is enabled by Bistable 540, the gate voltage from Bistable 548 is coupled through AND Gate 542 to a group of bit AND Gates 550 through 556. These bit gates permit data bits to be coupled to the Response AND Gates in the Remote Transceiver, FIG. 7.

If any command has been executed incorrectly, or if a circuit malfunction has occurred, one of two circumstances will exist for the output lines from Logic 534. The first circumstance will occur when more than one output line from Logic 534 is energized. The second circumstance will occur when none of the output lines from Logic 534 is energized. For the latter case, there will be no input to or output from OR Gate 538 within the Logic 536. Consequently, Bistable 540 will not be activated, AND Gate 542 will not be enabled, and the bit AND gates 550 through 556 will not be enabled. Therefore, no discrete command bit data can be transmitted back to the Central Facility 10. If more than one output line from Logic 534 is energized, at least two AND Gates within Logic 536 circuitry will be enabled. Since at least one of the enabled AND Gates is incorrect, it is most probable that the line output from Logic 532 which is coupled to this incorrectly enabled AND Gate will be energized. This is because it is almost impossible for all of the R inputs to this line to be inactive. In such a circumstance, OR Gate 546 within Logic 536 will pass the energized line voltage to Bistable 548. With an input voltage, Bistable 548 will not output a voltage gate. Therefore, there will not be a voltage gate output from AND Gate 542, in spite of the fact that AND Gate 542 may be enabled from the output of Bistable 540. Consequently, the bit AND Gates 550 through 556 will be disabled, and no discrete command bit data can be transmitted back to the Central Facility 10.

The output lines from Logic 534 are also coupled appropriately to the four bit lines. Therefore, when any command has been executed correctly, the correspondingly numbered output line from Logic 534 will be energized. This voltage will be coupled to the correct bit lines by means of indicated diodes. The bit line voltages are coupled through the enabled bit AND Gates 550 through 556 to the attached Remote Transceiver 26.

The Remote Control mode is evidenced by an energized 326 R input voltage. This voltage may be coupled directly to the appropriate Response AND Gate in the attached Remote Transceiver 26.

The Flashing Mode for Emergency Vehicle Control signals is evidenced by an energized 328 R input voltage. This voltage may be utilized to enable a group of AND Gates 558, 560 and 562. The corresponding Emergency Command, when executed correctly, will energize one of the output lines No. 11, No. 12, or No. 13 from Logic 534. These Emergency Command lines also are appropriately coupled through one of the enabled AND Gates, 558, 560 or 562 to the appropriate bit lines.

It is noted that the disclosed Communication Link System can also be utilized to detect and transmit information relative to a burned out traffic lamp indicator. If a ½ ohm (or less) dropping resistor were inserted in each lamp indicator circuit, the voltage drop across this resistor could be detected when the lamp circuit is active. When a lamp indicator is burned out, the voltage drop will decrease on a line which accommodates several lamp indicators in parallel, or the voltage drop would be eliminated if only one lamp indicator were attached to the line. The decrease or elimination of a voltage drop, when it occurs, can be coupled to appropriate logic circuitry, and transmitted back to the Central Facility 10. For a large metropolitan area with many remotely controlled traffic lights, this feature will reduce maintenance crew expense by a significant amount.

An example burn-out detection circuit is shown in FIG. 15. The AC voltages present at each terminal of the dropping resistor 580 are voltage-divided and half-wave rectified by a pair of diodes 564 and 566. The 564 diode rectified output voltage may be filtered by a Capacitor 568, and furnishes collector voltage to a pair of Transistors 570 and 572. The 566 diode rectified output voltage furnishes base voltage to Transistor 570. When AC voltage is applied to the lamp circuit, the collector of Transistor 572 will be established at some relatively stable value of voltage at an output 574, dependent on the transistor characteristics and the associated resistor values. The voltage value at output 574 is adjusted such that a Zener diode 576 will not conduct. That is, the voltage level at output 574 is too small to cause conduction in Zener diode 576. However, when a lamp indicator burn-out occurs, the rectified voltage increase at diode 566 raises the base voltage of Transistor 570. This action decreases the collector voltage of Transistor 570, which is directly coupled to the base Transistor 572. Therefore, the collector of Transistor 572 rises to some higher value, sufficient to cause conduction of Zener diode 576. When the Zener diode conducts, a voltage is produced at an output 578. It is noted that when the lamp indicator circuit is removed from input AC power, the collector voltages of Transistors 570 and 572 are also removed. Therefore, no volt-

age is produced at output 578. This feature is useful since a voltage output at 578 only occurs when the voltage drop across a dropping resistor 580 is less than a predetermined value. Therefore, the 578 outputs for all lamp indicator circuits at a given intersection can be logically OR'd in an OR gate 582. If any one lamp circuit contains a burned-out lamp, there will be a resultant voltage output from the OR gate 582.

The output of OR Gate 582 can be coupled to a Monostable 584. When the output of OR Gate 582 is zero, the output of Monostable 584 may be adjusted to disable AND Gate 586. When the OR Gate 582 produces an output voltage, the output of Monostable 584 may be adjusted to enable AND Gate 586. The input to AND Gate 586 can be attached to the No. 1 line output from Logic 534 of FIG. 14. This line is energized only when the No. 1 Green Command has been executed correctly. Therefore, when the output of OR Gate 582 is zero, representing no burn-out for any lamp indicator, AND Gate 586 will be disabled, and there will be no output.

When the OR Gate 582 outputs a voltage, representing at least one burned-out lamp indicator, AND Gate 586 will be enabled. Subsequently, each time the No. 1 Green Command is executed, the voltage on line No. 1 from Logic 534 will be coupled through AND Gate 586. AND Gate 586 is coupled to the No. 5 bit line. Therefore, the No. 1 Green Command will appear as the four-bit command signal of 1001. When the Remote Control Mode bit is added, the 5-bit No. 1 Green Command would appear as 11001. When this response signal is transmitted via the remote unit to the Central Facility 10, detection of the response bits 11001 may be accessed as a No. 1 Green Command response plus the additional information, contained in the last binary bit value of one, that there exists a burned-out traffic lamp indicator at the remote unit location which produced the information. Finally, it is noted in FIG. 15, that the 574 outputs from the various lamp circuits may be utilized as the R input signals 288 through 324 in FIG. 14, without the need for additional circuitry to supply these input signals.

VII. DESCRIPTION OF PREFERRED CIRCUITRY FOR SIGNAL

RESPONSES OTHER THAN TRAFFIC LAMP INDICATOR CIRCUITS

FOR THE COMMUNICATION LINK SYSTEM

It has been mentioned previously that Remote Transceivers 26 may be utilized with vehicle detection devices. Also, if an auxiliary receiver circuit is added to a remote unit, a means exists for processing information relative to the presence of emergency vehicles or other vehicles which may be under control of the various service departments of a municipality.

On-the-street vehicle detection devices are currently utilized in a number of different ways. In general, these functions may remain unaltered under the Remote Control Mode for the Traffic and Transportation Communication Link System. The application of the Communication Link System, however, provides a unique means for transmission of all vehicle detection data to the Central Facility 10, if such data are desired at the Central Facility. A vehicle detection device which detects vehicle presence only would require only one binary bit output to convey this information. Thus, vehi-

cle presence could be indicated by a one value of the binary bit and vehicle absence would be indicated by a zero value of the binary bit. A vehicle detection device which is used to count vehicles or to determine vehicle movement or speed, in general, will require the use of two binary bits, if these data are to be transmitted to the Central Facility. For instance, for moving vehicles between 10 mph and 70 mph, a single vehicle counter for one traffic lane would be required to count at a rate no faster than one vehicle per second. Usually, this count rate would be from 1.5 to 2 seconds per vehicle. Therefore, for a communication cycle time length of about 2 seconds, a maximum count rate of two vehicles per communication cycle time would be experienced. Thus, two binary bits can be utilized to convey this information. Furthermore, at a simple two-street intersection with control functions as depicted in FIG. 13, the two vehicle detection bits from a nearby vehicle detection device could be processed in the remote unit, together with the response command data signals, which correspond to the traffic lamp indicators. This would be possible, also, for intersections which require three bits of response command data, since each remote unit is permitted a response time interval equivalent to a 5-bit response signal.

Other installations may require inputs from several vehicle detection devices which may be located nearby to a given remote unit. In such cases, the response time interval for a given remote unit may be increased from one interval to two, three, or more response time intervals. For instance, let it be assumed that three response time intervals were allotted to a given remote unit, for an intersection which required 3-bit commands. A 3-bit command could permit four remotely controlled traffic functions at the intersection. In such a circumstance, the use of three response time intervals for the attached remote unit would permit data from six vehicle detection devices to be processed, together with the response command data for the given intersection. It is noted, however, that an increase of the response time interval for any given remote unit will decrease the total time available for responses from other remote units attached to the same communication line. Therefore, the total number of possible remote units on the communication line would be reduced. For the circuitry discussed in relation to FIG. 10, there is ample communication cycle time available for command and response of at least 150 separate remote units attached to the same communication line. Therefore, if two response time intervals were allotted to one of these remote units, the total number of possible remote units would be reduced from 150 to 149, for the communication line.

It is noted that any vehicle detection device or a group of vehicle detection devices may be utilized together with their own dedicated Remote Transceiver 26. The data output from each vehicle detection device may be processed, for instance, to the form of binary data bits and input to the response circuits in the receiver section of the attached Remote Transceiver 26. A preferred embodiment of such circuitry is shown in FIG. 16. It has been assumed that two response time intervals have been allotted to the attached Remote Transceiver 26. For this case, six Vehicle Detection Devices or Vehicle Detectors 30 may utilize the same remote unit. Thus, six inputs 588 and 598 are shown in FIG. 16. Each input is assumed to result from an at-

tached Vehicle Detection Device 30 which is counting vehicles. If Two Counters are utilized, as illustrated at 600 to 610, when 1 count is received, the corresponding 1 count line to one of the attached Monostables 612 to 632 would be energized. For instance, if 1 count were received for the No. 1 Vehicle Detection Device over line 588, Monostable 612 would be activated. The output of Mono stable 612 can be coupled to a Response AND Gate 254 in the response circuitry of the receiver section, FIG. 7, of the attached Remote Transceiver. When Response AND Gate 254 is enabled at the appropriate response time, the binary bit value of one would be inserted into the OR Gate 256, FIG. 7. Subsequently, when a second count is received from the No. 1 vehicle detection device on the 588 count line FIG. 16, Monostable 614 would be energized and a binary bit value of one would be coupled to Response AND gate 252.

When Response AND Gates 252 and 254 are enabled in a serial manner in the receiver section at the appropriate response time, the binary bit values input to OR Gate 256 could comprise any one of the following sets of values. First, both bit values could be zero, indicating no vehicle counts. Second, the first bit value could be zero and the second bit value could be one, indicating one vehicle count. Third, the first bit value could be one and the second bit value could be zero, indicating two vehicle counts. If the Two-Counter were replaced with a Three-Counter, a fourth circumstance could be accommodated, if desired. Thus, an additional Monostable could be added, such that its output enabled, simultaneously, both Response AND Gates 252 and 254. Therefore, the binary bit values of one and one could indicate three vehicle counts. Similar results would occur from the remaining inputs 590 through 598 in FIG. 16.

The Two-counters 600 through 610 may reset once each communication cycle time by the same pulse utilized to reset the Response Counter 250 circuit of FIG. 7. In the present circumstance, where two response interval times are allotted to a given remote unit, the Response Counter 250 in FIG. 7 would still be reset on the $n + 2$ count. However, the value of n would be 12 in the present circumstance. Therefore, the total discrete response time interval for the attached remote unit would be equivalent to 13 bit times. This results because the assumed one-way transmission delay of 2.5 milliseconds would not be necessary between the two sequential time response intervals. This is because the response bits contained in both time response intervals are all transmitted from the same remote unit. Thus, the additional 2.5 milliseconds of time, which is available, can be utilized to process data from the sixth additional vehicle detection device. Actually, in the present circumstance, only 12 of the available 13 bit times are utilized to transmit the 12 bits from the six vehicle detection devices.

Finally, the presence of any suitably equipped vehicle may be detected at any given intersection. For instance, if an emergency vehicle is equipped with a transmitter and if a suitable receiver is attached to a given remote unit, the presence of this vehicle in the vicinity of the remove unit may be detected. This information may then be transmitted to the Central Facility 10. For instance, let it be assumed that a low power transmitter is attached to a vehicle, such that a transmission range of 250 to 350 feet is available. Further

let it be assumed that a suitable receiver is attached to a Remote Transceiver 26, located at a given intersection. The vehicle may be assigned a number from 1 to 31. These numbers represent the different possible combinations of a 5-bit response signal, neglecting the response signal of 00000. Whenever, this vehicle is within, say, 250 feet of the given intersection, the receiver detects the particular transmitted signal from the vehicle. The output of the receiver can be processed, such that unique data bits, representative of this particular vehicle, may be input to the response circuitry of the receiver section of a Remote Transceiver 26. These data may then be transmitted back to the Central Facility 10 during the appropriate response time interval assigned to the remote unit. In larger metropolitan areas, there would exist, in general, a need for representation of a larger number of vehicles than the 31 possible with a 5-bit response signal. If two response time intervals were allotted to the remote unit, a total of 1,024 separate vehicles could be detected.

In some instances, it might be desirable to maintain surveillance of several emergency vehicles in the vicinity of an intersection, for instance, in the case of a major accident. In such a circumstance, transponder equipment and/or separate frequencies might be utilized for the emergency vehicles. In any case, the data received from each emergency vehicle may be stored and processed in a serial manner, once each communication cycle. For instance, if the communication cycle were two seconds, data corresponding to each emergency vehicle present might be transmitted serially, one vehicle per communication cycle. For 10 vehicles present, 10 communication cycles would be required for transmittal of the separate data relating to the presence of each emergency vehicle. The total time required in this instance would be approximately 20 seconds.

What is claimed as new and desired to be secured by Letters Patent of the United States is:

1. An automated traffic control system comprising:
 - a central control facility, said central control facility including computer means for processing input information signals and for generating traffic control signals, and
 - computer interface means in said central control facility coupled to said computer for applying said input information signals to said computer means and for transmitting said traffic control signals from said computer means;
 - signal communication means in said central control facility, said signal communication means coupled to said interface means and including multiplexing means;
 - a single communication line coupled to said signal communication means for transmitting signals to and from remote points; and
 - a plurality of remote terminal means coupled to said single communication line in parallel, party-line fashion for receiving said traffic control signals from said computer means and for supplying said input information signals to said computer means over said single communication line.
2. An automated traffic control system as in claim 1, wherein: said communication line includes a voice grade, non-compensated communication line.
3. An automated traffic control system as in claim 1, wherein:

- said computer means comprises a digital computer facility.
4. An automated traffic control system as in claim 1, wherein:
- said signal communication means includes master transceiver means coupled to said communication line for transmitting signals over and receiving signals from said communication line.
5. An automated traffic control system as in claim 4, wherein:
- said computer interface means includes input-output storage register means for temporarily accumulating signals to be fed into said computer means and for temporarily accumulating signals generated by said computer means.
6. An automated traffic control system as in claim 4, wherein:
- said master transceiver means includes a coarse synchronization signal generating means for conditioning said remote terminal means to receive a synchronization signal.
7. An automated traffic control system as in claim 4, wherein:
- said master transceiver means includes a fine synchronization signal generating means for preparing said remote terminal means to receive and decode data from said central control facility.
8. An automated traffic control system as in claim 4, wherein:
- said master transceiver means includes means for generating a stable carrier reference for enabling said remote terminal means to decode data transmitted from said central control facility.
9. An automated traffic control system as in claim 4, wherein:
- said master transceiver means includes means for establishing a data input gate interval for defining a period during which data is transmitted from said central control facility to said remote terminal means.
10. An automated traffic control system as in claim 4, wherein:
- said master transceiver means includes means for establishing a data response gate interval for defining a period during which data is transmitted from said remote terminal means to said central control facility.
11. An automated traffic control system as in claim 4, wherein:
- said master transceiver means includes said multiplexing means for permitting time shared use of said communication line.
12. An automated traffic control system as in claim 4, wherein:
- said remote transceiver means includes means for recognizing only traffic control signals which are directed uniquely to a particular one of said remote transceiver means.
13. An automated traffic control system as in claim 1, wherein:
- Said remote terminal means include remote transceiver means coupled to said communication line for transmitting signals over and receiving signals from said communication line.
14. An automated traffic control system as in claim 13, wherein:

- said remote terminal means include traffic control means for regulating traffic flow; and, terminal interface equipment for coupling said traffic control means with said remote transceiver means.
15. An automated traffic control system as in claim 14, wherein:
- said central control facility includes a visual display means for displaying the various conditions of said traffic control devices.
16. An automated traffic control system as in claim 14, wherein:
- said remote terminal means include local controller means for controlling the operation of said traffic control means according to a self-contained predetermined program.
17. An automated traffic control system as in claim 16 wherein:
- said remote terminal means include emergency vehicle detector means for sensing the presence of emergency vehicles; and, said terminal interface equipment includes means for disabling said local controller means in response to the detection of an emergency vehicle by said emergency vehicle-detector means.
18. An automated traffic control system as in claim 17, wherein:
- said remote terminal means includes sequencing means for rendering said mean for disabling said local controller means inoperative until after a prescribed signal is received from said central control facility.
19. An automated traffic control system as in claim 17, wherein:
- said terminal interface equipment includes means for causing said traffic control means to produce a signal indicative of the presence of an emergency vehicle.
20. An automated traffic control system as in claim 14, wherein:
- said traffic control means include indicator lamp means for producing visual traffic regulating signals.
21. An automated traffic control system as in claim 14, wherein:
- said remote terminal means include signal generator means for generating a signal in response to said traffic control means becoming inoperative.
22. An automated traffic control system as in claim 13, wherein:
- said remote terminal means include vehicle detector means coupled to said remote transceiver means for measuring parameters of traffic flow.
23. An automated traffic control system as in claim 13, wherein:
- said remote terminal means include emergency vehicle detector means coupled to said remote transceiver means for sensing the presence of emergency vehicles.
24. An automated traffic control system as in claim 13, wherein:
- said remote transceiver means includes data receiver means for accepting said traffic control signals from said central control facility.
25. An automated traffic control system as in claim 24, wherein:

39

said remote transceiver means includes coarse synchronization signal detecting means for preparing said data receiver means to receive traffic control signals from said central control facility.

26. An automated traffic control system as in claim 5 24, wherein:

said remote transceiver means includes fine synchronization signal detecting means for preparing said data receiver means to decode traffic control signals from said central control facility.

27. An automated traffic control system as in claim 10 26, wherein:

said fine synchronization signal detecting means includes means for establishing a stable reference signal for demodulation of said traffic control signals from said central control facility.

28. An automated traffic control system as in claim 15 27, wherein:

said fine synchronization signal detecting means includes phase sensitive means for determining whether said stable reference signal is in phase with a signal from said central control facility, or 180° out of phase with said signal from said central control facility.

29. An automated traffic control system as in claim 20 27, wherein:

40

said remote transceiver means includes response modulator means for producing pulse amplitude modulation of said stable reference signal.

30. An automated traffic control system as in claim 13, wherein:

said remote transceiver means includes logic means for demultiplexing said traffic control signals from said central control facility and for multiplexing said input information signals for transmission to said central control facility.

31. An automated traffic control system as in claim 13, wherein:

said remote terminal means include vehicle sensing means for detecting the presence of vehicles.

32. An automated traffic control system as in claim 13, wherein:

said remote terminal means include vehicle counting means for determining the number of passing vehicles.

33. An automated traffic control system as in claim 13, wherein:

said remote terminal means include vehicle speed detectors for determining the speeds of passing vehicles.

* * * * *

30

35

40

45

50

55

60

65