

GEORGIA INSTITUTE OF TECHNOLOGY
OFFICE OF CONTRACT ADMINISTRATION
SPONSORED PROJECT INITIATION

no action
WJG

Date: 8/7/78

Project Title: Lower Reservoir Main Spillway

Project No: E-20-637 (Co-Project w/E-20-638/Martin/CE)

Project Director: Dr. P. G. Mayer

Sponsor: Southern Company Services

Dr. CD
CD

Agreement Period: From 6/30/78 Until 5/1/79

Type Agreement: Standard Industrial Research Agreement

Amount: \$60,200

Reports Required: Initial Results

Sponsor Contact Person (s):

Technical Matters

Contractual Matters
(thru OCA)

Mr. G. B. Dougherty, Manager
Hydro-Projects Department
Southern Company Services
P. O. Box 2625
Birmingham, AL 35202

Defense Priority Rating: None

Assigned to: Civil Engineering (School/Laboratory)

COPIES TO:

Project Director
Division Chief (EES)
School/Laboratory Director
Dean/Director-EES
Accounting Office
Procurement Office
Security Coordinator (OCA)
Reports Coordinator (OCA)

Library, Technical Reports Section
EES Information Office
EES Reports & Procedures
Project File (OCA)
Project Code (GTRI)
Other _____

GEORGIA INSTITUTE OF TECHNOLOGY
OFFICE OF CONTRACT ADMINISTRATION
SPONSORED PROJECT TERMINATION

Date: 9/11/80

Project Title: Lower Reservoir Main Spillway

Project No: E-20-637 (Co-Project w/E-20-638/Martin/CE)

Project Director: Dr. P.G. Mayer

Sponsor: Southern Company Services

Effective Termination Date: 12/31/79

Clearance of Accounting Charges: 12/31/79

Grant/Contract Closeout Actions Remaining:

- Final Invoice ~~and Closing Documents~~
- Final Fiscal Report
- Final Report of Inventions
- Govt. Property Inventory & Related Certificate
- Classified Material Certificate
- Other _____

Assigned to: Civil Engineering (School/~~Laboratory~~)

COPIES TO:

Project Director
Division Chief (EES)
School/Laboratory Director
Dean/Director—EES
Accounting Office
Procurement Office
Security Coordinator (OCA)
 Reports Coordinator (OCA)

Library, Technical Reports Section
EES Information Office
Project File (OCA)
Project Code (GTRI)
Other C.E. Smith

Final Report

Project No. E-20-637

110-
S.P. 400

**ROCKY MOUNTAIN PROJECT
LOWER RESERVOIR MAIN SPILLWAY
HYDRAULIC MODEL STUDY**

By

Paul G. Mayer

Prepared for

**SOUTHERN COMPANY SERVICES
BIRMINGHAM, ALABAMA**

December, 1979

GEORGIA INSTITUTE OF TECHNOLOGY

**SCHOOL OF CIVIL ENGINEERING
ATLANTA, GEORGIA 30332**

1979



ROCKY MOUNTAIN PROJECT
LOWER RESERVOIR MAIN SPILLWAY
HYDRAULIC MODEL STUDY

by
Paul G. Mayer

Project No. E-20-637
Southern Company Services
Birmingham, Alabama

December, 1979

TABLE OF CONTENTS

	Page
I. Introduction	1
II. Purpose and Scope	2
III. The Hydraulic Model	5
IV. Procedures and Test Results - Preliminary Models	7
V. Test Results - The "Final" Model	14
VI. The Energy Dissipator	20
VII. Summary and Conclusions	28
List of Figures	i
List of Tables	viii

List of Figures

		Page
Figure 1	Laboratory Schematic	33
Figure 2	Bird's-Eye View of Spillway Model in Laboratory	34
Figure 3	Oblique View of Spillway Model in Laboratory	35
Figure 4	Typical Vertical Cross-Section	36
Figure 5	Typical Horizontal Section	37
Figure 6	Nappe Profile, Definition Sketch	38
Figure 7	Spillway Geometry, Plan View	39
Figure 8	Detail of Interior Pier Model I	40
Figure 9	Spillway Rating Curve Model I	41
Figure 10	Water Surface Profile Model I, Q = 40,000 cfs, Bay No. 1	42
Figure 11	Water Surface Profile Model I, Q = 40,000 cfs, Bay No. 2	43
Figure 12	Water Surface Profile Model I, Q = 40,000 cfs, Bay No. 3	44
Figure 13	Water Surface Profile Model I, Q = 50,000 cfs, Bay No. 1	45
Figure 14	Water Surface Profile Model I, Q = 50,000 cfs, Bay No. 2	46
Figure 15	Water Surface Profile Model I, Q = 50,000 cfs, Bay No. 3	47
Figure 16	Water Surface Profile Model I, Q = 60,000 cfs, Bay No. 1	48
Figure 17	Water Surface Profile Model I, Q = 60,000 cfs, Bay No. 2	49

	Page	
Figure 18	Water Surface Profile Model I, Q = 60,000 cfs, Bay No. 3	50
Figure 19	Water Surface Profile Model I, Q = 60,700 cfs, Bay No. 1	51
Figure 20	Water Surface Profile Model I, Q = 60,700 cfs, Bay No. 2	52
Figure 21	Water Surface Profile Model I, Q = 60,700 cfs, Bay No. 3	53
Figure 22	Water Surface Profile Model I, Q = 69,000 cfs, Bay No. 1	54
Figure 23	Water Surface Profile Model I, Q = 69,000 cfs, Bay No. 2	55
Figure 24	Water Surface Profile Model I, Q = 69,000 cfs, Bay No. 3	56
Figure 25	Detail of Interior Pier Model II	57
Figure 26	Spillway Rating Curve Model II	58
Figure 27	Water Surface Profile Model II, Q = 36,370 cfs, Bay No. 1	59
Figure 28	Water Surface Profile Model II, Q = 36,370 cfs, Bay No. 2	60
Figure 29	Water Surface Profile Model II, Q = 36,370 cfs, Bay No. 3	61
Figure 30	Water Surface Profile Model II, Q = 46,950 cfs, Bay No. 1	62
Figure 31	Water Surface Profile Model II, Q = 46,950 cfs, Bay No. 2	63
Figure 32	Water Surface Profile Model II, Q = 46,950 cfs, Bay No. 3	64

	Page
Figure 33 Water Surface Profile Model II, Q = 57,100 cfs, Bay No. 1	65
Figure 34 Water Surface Profile Model II, Q = 57,100 cfs, Bay No. 2	66
Figure 35 Water Surface Profile Model II, Q = 57,100 cfs, Bay No. 3	67
Figure 36 Water Surface Profile Model II, Q = 66,450 cfs, Bay No. 1	68
Figure 37 Water Surface Profile Model II, Q = 66,450 cfs, Bay No. 2	69
Figure 38 Water Surface Profile Model II, Q = 66,450 cfs, Bay No. 3	70
Figure 39 Plan View Model III	71
Figure 40 Spillway Rating Curve Model III	72
Figure 41 Water Surface Profile Model III, Q = 37,210 cfs, Bay No. 1	73
Figure 42 Water Surface Profile Model III, Q = 37,210 cfs, Bay No. 2	74
Figure 43 Water Surface Profile Model III, Q = 37,210 cfs, Bay No. 3	75
Figure 44 Water Surface Profile Model III, Q = 48,060 cfs, Bay No. 1	76
Figure 45 Water Surface Profile Model III, Q = 48,060 cfs, Bay No. 2	77
Figure 46 Water Surface Profile Model III, Q = 48,060 cfs, Bay No. 3	78
Figure 47 Water Surface Profile Model III, Q = 57,560 cfs, Bay No. 1	79

	Page
Figure 48 Water Surface Profile Model III, Q = 57,560 cfs, Bay No. 2	80
Figure 49 Water Surface Profile Model III, Q = 57,560 cfs, Bay No. 3	81
Figure 50 Water Surface Profile Model III, Q = 66,450 cfs, Bay No. 1	82
Figure 51 Water Surface Profile Model III, Q = 66,450 cfs, Bay No. 2	83
Figure 52 Water Surface Profile Model III, Q = 66,450 cfs, Bay No. 3	84
Figure 53 Water Surface Profile Model III, Q = 69,560 cfs, Bay No. 1	85
Figure 54 Water Surface Profile Model III, Q = 69,560 cfs, Bay No. 2	86
Figure 55 Water Surface Profile Model III, Q = 69,560 cfs, Bay No. 3	87
Figure 56 Plan View Model V	88
Figure 57 Detail of Interior Pier Model V	89
Figure 58 Detail of Interior Pier Model VIII	90
Figure 59 Detail of End Pier Model VIII	91
Figure 60 Detail of End Pier Model IX	92
Figure 61 Detail of Interior Pier Model X	93
Figure 62 Detail of Interior Pier Model XII	94

	Page	
Figure 63	Water Surface Profile Model XII, Q = 63,720 cfs, Bay No. 1	95
Figure 64	Water Surface Profile Model XII, Q = 63,720 cfs, Bay No. 2	96
Figure 65	Water Surface Profile Model XII, Q = 63,720 cfs, Bay No. 3	97
Figure 66	Detail of Interior and End Pier Model XIII	98
Figure 67	Plan View Model XIII	99
Figure 68	Detail of Gate Trunion Model XIII	100
Figure 69	Water Surface Profile Model XIII, Q = 40,700 cfs, Bay No. 1	101
Figure 70	Water Surface Profile Model XIII, Q = 40,700 cfs, Bay No. 2	102
Figure 71	Water Surface Profile Model XIII, Q = 40,700 cfs, Bay No. 3	103
Figure 72	Water Surface Profile Model XIII, Q = 60,000 cfs, Bay No. 1	104
Figure 73	Water Surface Profile Model XIII, Q = 60,000 cfs, Bay No. 2	105
Figure 74	Water Surface Profile Model XIII, Q = 60,000 cfs, Bay No. 3	106
Figure 75	Low Discharge Rating Curve for Ungated Flows Model XIII	107
Figure 76	Gated Spillway Discharges Hysteresis Study	108
Figure 77	Free Overflow and Gated Flow Rating Curves	109

	Page	
Figure 78	Bucket Type Dissipator, 45° Exit Angle Invert Elevation: 635 Feet Exit Lip Elevations: 642, 646 Feet	110
Figure 79	Bucket Type Dissipator Wingwalls Plan View, 5° Flare Angle	111
Figure 80	Tailrace Velocity Profile Definition Sketch	112
Figure 81	Bucket Type Dissipator, 37.5° Exit Angle Invert Elevation: 635 Feet Exit Lip Elevations: 642, 646 Feet	113
Figure 82	Bucket Type Dissipator, 30° Exit Angle Invert Elevation: 635 Feet Exit Lip Elevation: 640, 642, 646 Feet	114
Figure 83	Bucket Type Dissipator, 45° Exit Angle Invert Elevation: 630 Feet Exit Lip Elevation: 646 Feet	115
Figure 84	Bucket Type Dissipator, 37.5° Exit Angle Invert Elevation: 630 Feet Exit Lip Elevations: 642, 646 Feet	116
Figure 85	Bucket Type Dissipator, 30° Exit Angle Invert Elevation: 630 Feet Exit Lip Elevations: 642, 646 Feet	117
Figure 86	Bucket Type Dissipator, 0° Ramp Angle Invert Elevation: 630 Feet Exit Lip Elevation: 630 Feet	118
Figure 87	Bucket Type Dissipator, 10° Ramp Angle Invert Elevation: 630 Feet Exit Lip Elevations: 637.5, 640 Feet	119
Figure 88	Bucket Type Dissipator, 20° Ramp Angle Invert Elevation: 630 Feet Exit Lip Elevations: 642, 646 Feet	120
Figure 89	Bucket Type Dissipator, 30° Ramp Angle Invert Elevation: 630 Feet Exit Lip Elevations: 642, 646 Feet	121
Figure 90	Bucket Type Dissipator Wingwalls Typical Elevation Views	122

		Page
Figure 91	Bucket Type Dissipator Wingwalls Plan View, 7.5° Flare Angle	123
Figure 92	Bucket Type Dissipator Wingwalls Plan View, 7.5°, 15° Flare Angles	124
Figure 93	Bucket Type Dissipator Wingwalls Plan View, 7.5°, 22.5° Flare Angles	125
Figure 94	Bucket Type Dissipator Wingwalls Plan View, 7.5° , 30° Flare Angles	126
Figure 95	Bucket Type Dissipator Extended Wingwalls Plan View, 7.5° , 30° Flare Angles	127
Figure 96	Tailrace Scour Pattern	128

List of Tables

Page

Table 1	Spillway Rating, Ungated Flow Model I	129
Table 2	Spillway Water Surface Survey Model I, Q = 40,000 cfs	130
Table 3	Spillway Water Surface Survey Model I, Q = 50,000 cfs	131
Table 4	Spillway Water Surface Survey Model I, Q = 60,000 cfs	132
Table 5	Spillway Water Surface Survey Model I, Q = 60,700 cfs	133
Table 6	Spillway Water Surface Survey Model I, Q = 69,000 cfs	134
Table 7	Spillway Rating, Ungated Flow Model II	135
Table 8	Spillway Water Surface Survey Model II, Q = 36,400 cfs	136
Table 9	Spillway Water Surface Survey Model II, Q = 46,950 cfs	137
Table 10	Spillway Water Surface Survey Model II, Q = 57,100 cfs	138
Table 11	Spillway Water Surface Survey Model II, Q = 66,450 cfs	139
Table 12	Spillway Rating, Ungated Flow Model III	140
Table 13	Spillway Water Surface Survey Model III, Q = 37,210 cfs	141
Table 14	Spillway Water Surface Survey Model III, Q = 48,060 cfs	142
Table 15	Spillway Water Surface Survey Model III, Q = 57,560 cfs	143

	Page	
Table 16	Spillway Water Surface Survey Model III, Q = 66,450 cfs	144
Table 17	Spillway Water Surface Survey Model III, Q = 69,000 cfs	145
Table 18	Spillway Rating, Ungated Flow Model IV	146
Table 19	Spillway Rating, Ungated Flow Model V	147
Table 20	Spillway Rating, Ungated Flow Model VI	148
Table 21	Spillway Rating, Ungated Flow Model VII	149
Table 22	Spillway Rating, Ungated Flow Model VIII	150
Table 23	Spillway Rating, Ungated Flow Model IX	151
Table 24	Spillway Rating, Ungated Flow Model X	152
Table 25	Spillway Rating, Ungated Flow Model XI	153
Table 26	Spillway Rating, Ungated Flow Model XII	154
Table 27	Spillway Water Surface Survey Model XII, Q = 63,720 cfs	155
Table 28	Spillway Water Surface Survey Model XII, Q = 70,600 cfs	156
Table 29	Spillway Rating, Ungated Flow 30 Feet Bay Width	157
Table 30	Spillway Water Surface Survey Model XIII, Q = 40,700 cfs	158

	Page	
Table 31	Spillway Water Surface Survey Model XIII, Q = 60,000 cfs	159
Table 32	Low Discharge Spillway Rating, Ungated Flows Model XIII	160
Table 33	Gated Spillway Discharges, Hysteresis Study Model XIII, Gate Openings 20 Feet	161
Table 34	Gated Spillway Discharges, Hysteresis Study Model XIII, Gate Openings 20 Feet	162
Table 35	Gated Spillway Discharges, Hysteresis Study Model XIII, Gate Openings 15 Feet	163
Table 36	Gated Spillway Discharges, Hysteresis Study Model XIII, Gate Openings 10 Feet	164
Table 37	Gated Spillway Discharges, Hysteresis Study Model XIII, Gate Openings 5 Feet	165
Table 38	Rating of Tainter Gates, 30 Foot Bays Gate Openings, 0-8 Inches-0	166
Table 39	Rating of Tainter Gates, 30 Foot Bays Gate Openings, 8-8-8 (Inches)	167
Table 40	Rating of Tainter Gates, 30 Foot Bays Gate Openings, 16-16-16 (Inches)	168
Table 41	Rating of Tainter Gates, 30 Foot Bays Gate Openings, 0-24 Inches-0	169
Table 42	Rating of Tainter Gates, 30 Foot Bays Gate Openings, 0-32 Inches-0	170
Table 43	Rating of Tainter Gates, 30 Foot Bays Gate Openings, 0-4 Feet-0	171
Table 44	Rating of Tainter Gates, 30 Foot Bays Gate Openings, 0-4 Feet-0	172
Table 45	Rating of Tainter Gates, 30 Foot Bays Gate Openings, 0-5 Feet-0	173

	Page	
Table 46	Rating of Tainter Gates, 30 Foot Bays Gate Openings, 1-5-1 (Feet)	174
Table 47	Rating of Tainter Gates, 30 Foot Bays Gate Openings, 2-5-2 (Feet)	175
Table 48	Rating of Tainter Gates, 30 Foot Bays Gate Openings, 3-5-3 (Feet)	176
Table 49	Rating of Tainter Gates, 30 Foot Bays Gate Openings, 4-5-4 (Feet)	177
Table 50	Rating of Tainter Gates, 30 Foot Bays Gate Openings, 5-5-5 (Feet)	178
Table 51	Rating of Tainter Gates, 30 Foot Bays Gate Openings, 10-10-10 (Feet)	179
Table 52	Rating of Tainter Gates, 30 Foot Bays Gate Openings, 15-15-15 (Feet)	180
Table 53	Rating of Tainter Gates, 30 Foot Bays Gate Openings, 20-20-20 (Feet)	181
Table 54	Summary of Dissipator Test Conditions	182
Table 55	Flip Bucket Type Energy Dissipator, 45° Angle	183
Table 56	Tailrace Velocity Survey Exit Lip Angle: 45°, Q = 30,000 cfs	184
Table 57	Tailrace Velocity Survey Exit Lip Angle: 45°, Q = 60,000 cfs	185
Table 58	Flip Bucket Type Energy Dissipator, 37.5° Angle	186
Table 59	Tailrace Velocity Survey Exit Lip Angle: 37.5°, Q = 30,000 cfs	187
Table 60	Tailrace Velocity Survey Exit Lip Angle: 37.5°, Q = 30,000 cfs	188

	Page	
Table 61	Tailrace Velocity Survey Exit Lip Angle: 37.5°, Q = 60,000 cfs	189
Table 62	Tailrace Velocity Survey Exit Lip Angle: 37.5°, Q = 60,000 cfs	190
Table 63	Flip Bucket Type Energy Dissipator, 30° Angle	191
Table 64	Tailrace Velocity Survey Exit Lip Angle: 30°, Q = 30,000 cfs	192
Table 65	Tailrace Velocity Survey Exit Lip Angle: 30°, Q = 30,000 cfs	193
Table 66	Tailrace Velocity Survey Exit Lip Angle: 30°, Q = 30,000 cfs	194
Table 67	Tailrace Velocity Survey Exit Lip Angle: 30°, Q = 60,000 cfs	195
Table 68	Tailrace Velocity Survey Exit Lip Angle: 30°, Q = 60,000 cfs	196
Table 69	Tailrace Velocity Survey Exit Lip Angle: 30°, Q = 60,000 cfs	197
Table 70	Flip Bucket Type Energy Dissipator Water Surface Elevations	198
Table 71	Flip Bucket Type Energy Dissipator Water Surface Elevations	199
Table 72	Flip Bucket Type Energy Dissipator Water Surface Elevations	200
Table 73	Flip Bucket Type Energy Dissipator Water Surface Elevations	201
Table 74	Flip Bucket Type Energy Dissipator Water Surface Elevations	202
Table 75	Flip Bucket Type Energy Dissipator Water Surface Elevations	203

		Page
Table 76	Flip Bucket Type Energy Dissipator Water Surface Elevations	204
Table 77	Flip Bucket Type Energy Dissipator Water Surface Elevations	205
Table 78	Tailrace Velocity Survey Q = 20,000 cfs	206
Table 79	Tailrace Velocity Survey Q = 30,000 cfs	207
Table 80	Tailrace Velocity Survey Q = 45,000 cfs	208
Table 81	Tailrace Velocity Survey Q = 60,000 cfs	209

Final Report: Rocky Mountain Project Main Spillway Hydraulic Model Studies.

I. Introduction

The Rocky Mountain Project (RMP) is a proposed pumped storage hydroelectric power development located some 10 miles northwest of the city of Rome, Georgia. It will be a part of the Georgia Power Company System.

The project is a pure pumped storage development in which three reversible pump turbines will pump water from a lower operating pool into an upper reservoir during periods of low system load, and in which power will be generated to satisfy peak power demands.

The lower reservoir will be created by means of a man-made impoundment in the Heath Creek valley, a small stream with a watershed of less than 20 square miles drainage area. The lower reservoir provides for adequate storage to operate the project at dependable capacity. The impoundment structure contains an emergency spillway which will be capable of discharging the "probable maximum flood" (PMF) for that watershed. The proposed spillway is a three-bay structure with each bay provided with tainter gates.

The design, design verification, and design modification of the emergency spillway are subjected to careful study and review. In this context, Southern Company Services, Incorporated, of Birmingham, Alabama, contracted with the Georgia Institute of Technology to build and test a hydraulic model of the spillway from the lower reservoir. In the context of this contract the designation "Rocky Mountain Project

Main Spillway" was used. The liaison with Southern Company Services was carried out through Mr. G. B. Dougherty. The principal investigator was Dr. P. G. Mayer, Regents' Professor of Civil Engineering, Georgia Institute of Technology.

II. Purpose and Scope

The design of any emergency spillway incorporates provisions for passing maximum flood discharges and for the dissipation of excess kinetic energy in the downstream channel.

For the purpose of design and for design verification, a hydraulic model was built and tested. The model tests were specifically directed toward a spillway design which can accommodate discharges including the "probable maximum flood" (PMF) and which provides for adequate energy dissipation.

The scope of the tests was to develop or verify design information for

- a. end pier and interior pier shapes and locations,
- b. spillway bay widths,
- c. stop log slot locations,
- d. flip bucket geometry, and
- e. wingwall geometry.

In addition, the performance of the spillway and flip bucket type dissipator were to be tested in order to

- f. obtain spillway rating curves for gated and ungated discharges,
- g. obtain nappe profiles,
- h. define flow patterns in the dissipator,
- i. obtain velocity distributions in the downstream channel,
- j. define potential scour patterns.

The model test data were to be forwarded promptly to Mr. Dougherty for review and comment with requests for further instruction, as required. All test results were to be submitted in scope of the hydraulic model tests, any modification of the model, or any other work was to be under-

taken only by mutual agreement and by extension of the present contract.

III. The Hydraulic Model

In modeling the Main Spillway of the Rocky Mountain Project, both geometrical and dynamical similitude requirements were considered. It was agreed that dynamical similitude was based on the Froude criterion, that viscous effects can be neglected, and that surface tension effects can be minimized by the use of a sufficiently large scale hydraulic model.

A 1:40 scale model of the Rocky Mountain Project (RMP) Main Spillway was built according to specifications provided by Southern Company Services, Inc. The model was arranged to allow for considerable flexibility. The ogee section and the piers were made of plastics. The various pier shapes were made also of plastics and other suitable materials. The wingwalls were made of wood. The flip bucket was made of appropriately shaped sheet metal supported on plastic ribs. The bucket end sills were made of wood.

The model was inserted into a 66' X 24' basin. The model basin was divided into three compartments. One was a forebay in which the approach floor was modified by stilling devices and by a portion of the valley topography. The forebay was terminated by a water tight bulk head which also contained the spillway model. The next portion of the basin was a movable bed model which was shaped to reflect the valley topography. The model basin was terminated by an adjustable weir for tailwater control.

Water for model operation was obtained from the laboratory's floor channel system. Two centrifugal pumps of three cubic feet per second capacity each discharged through valve-controlled six-inch pipe lines into the forebay. Calibrated elbow meters were used to set

appropriate flow rates. Water surface elevations were measured throughout the model basin by a precision point gage mounted on a transverse instrument bridge which in turn could be moved longitudinally on a level track. Velocities were determined by the use of a midget current meter and by dye streaks, where appropriate. Photographic records were made of model details as well as some of the model performances.

Figure 1 shows a schematic of the laboratory arrangement, Figure 2 shows an aerial view of the hydraulic model basin, and Figure 3 shows an oblique close-up view of the RMP spillway model.

Before commencing with the various test programs efforts were made to obtain appropriate approach flow conditions in the head bay. Wire-mesh fencing and wooden baffles were used for that purpose. Subsequently, dye-streak observations and velocity measurements were made to verify the approach flow conditions. During this pre-test phase, flow meter calibrations and point gage calibrations were carried out in order to guarantee both reproducible flow rates through the model as well as accurate water level determinations.

IV. Procedures and Test Results - Preliminary Models

The 1:40 scale hydraulic model was tested in two stages. First, performance information was developed for the spillway and subsequently, information was developed for the flip bucket type energy dissipator.

The model was operated to satisfy the Froude Law of dynamic similitude, V^2/gL . Accordingly, in the 1:40 scale model the following relationships were used:

scale ratio 1:40

velocity ratio $(1:40)^{1/2} = 1:6.32$

discharge ratio $(1:40)^{5/2} = 1:10,120$

These ratios were used to convert prototype requirements into laboratory dimensions and to convert laboratory measurements into prototype quantities.

The Spillway Test Sequences. Originally, the spillway model was built to contain three 32.5-foot wide bays. The "original" model was alternately provided with twelve different combinations of end piers, interior piers, and pier locations. These configurations were designated as spillway Model I through Model XII. As a culmination of these efforts an "optimum" pier configuration was selected. Also the model tests established that 30-foot wide bays were sufficient to accommodate the PMF. A "final" Model XIII was built for verification tests. Model XIII contained the optimum pier shapes, 30-foot wide bays, and 25-foot radius tainter gates.

For each combination of pier geometry and bay width a series of ungated flows were discharged over the spillway models in order to obtain head-discharge relationships. The discharges ranged from low flows to the PMF of 60,000 cfs. For selected models, nappe water

surface profiles were also determined. For all models, flow patterns were observed; flow separation, air-entrainment, lift-off, and other undesirable conditions were carefully noted. Each of the test sequences usually suggested further refinements in the spillway geometry, leading finally to Model XIII.

Details of the vertical spillway cross section are shown in Figure 4. A typical horizontal cross section is shown in Figure 5. As shown in Figure 5 the end piers were usually made flush with the upstream end of the overflow section or were made to extend into the reservoir. The interior piers were usually placed at the spillway crest approximately six feet from the upstream end. The interior piers were typically eight feet wide. Water surface profiles were measured in each bay at various rates of flow. The locations of the measuring stations are shown in Figure 6.

In the following paragraphs the geometry of each spillway model is described and test results are presented.

Model I. Model I was characterized by three 32.5-foot wide spillway bays, by semi-circular end piers and by triangular interior piers. Figure 7 shows the geometry: the 8-foot radius, semi-circular end piers extended into the reservoir and the triangular interior piers located at the spillway crest. The details of the triangular interior piers are shown in Figure 8.

Model I was run through its paces in order to obtain information on head-discharge relationships and nappe water surface profiles. The head-discharge relationship or spillway rating for Model I is listed in Table 1, and is presented graphically in Figure 9. For the purpose of the water surface profile determinations each of the three bays was

investigated along five longitudinal sections as shown in the definition sketch in Figure 6. The water surface was determined in each section at ten measuring stations. For the spillway Model I the measurements were made with discharges of 40,000, 50,000, 60,000, 60,700 and 69,000 cubic feet per second. The correspondence between the tabular listing of the test data and the graphical presentation is indicated below:

40,000 cfs	Table 2	Figures 10, 11, 12
50,000	Table 3	Figures 13, 14, 15
60,000	Table 4	Figures 16, 17, 18
60,700	Table 5	Figures 19, 20, 21
69,000	Table 6	Figures 22, 23, 24

All test results are presented in prototype dimensions. In general, the laboratory tests showed that the spillway performed in a satisfactory way as far as could be judged by the absence of flow separation from the end walls, and by the absence of lift-off from the surface of the spillway.

Model II. Model II was characterized again by 32.5-foot wide bays and by 8-foot wide interior piers. The end piers were the same as in Model I: 8-foot radius, semi-circular with 4-foot radii and were located at the spillway crest. Figure 25 shows the details of the interior piers.

The spillway rating for Model II is listed in Table 7, and is presented graphically in Figure 26. The water surface data were collected for flow rates of 36,400, 47,000, 57,100 and 66,500 cubic feet per second. These data are listed and presented graphically as indicated on the next page:

36,000 cfs	Table 8	Figures 27, 28, 29
47,000	Table 9	Figures 30, 31, 32
57,100	Table 10	Figures 33, 34, 35
66,500	Table 11	Figures 36, 37, 38

Model III. In Model III semi-circular interior piers with a 4-foot radius were combined with 4-foot radius quarter-circle end piers. The end piers were set flush with the upstream face of the non-overflow section, and the interior piers were located at the spillway crest. Figure 39 shows a plan view of Model III, and Figure 25 shows details of the interior piers (same as Model II.)

The spillway rating for Model III is presented in Table 12 and in Figure 40. Water surface profiles were measured at flow rates of 37,200, 48,000, 57,600, 66,500 and 69,600 cubic feet per second. These data are listed and presented graphically as indicated below:

37,200	Table 13	Figures 41, 42, 43
48,000	Table 14	Figures 44, 45, 46
57,600	Table 15	Figures 47, 48, 49
66,500	Table 16	Figures 50, 51, 52
69,600	Table 17	Figures 53, 54, 55

Model IV. Model IV was essentially identical to Model III except that in Model III, the stop log slots had been omitted in the end piers. Thus, Figure 39 is also appropriate to Model IV. For Model

IV, the rating data are presented in Table 18.

Model V. Model V was characterized by quarter-circular end piers and by blunt triangular interior piers located at the spillway crest. Figure 56 shows the plan view of Model V. Figure 57 shows the details of the interior pier. Table 19 presents the spillway rating data for Model V.

Model VI. Model VI combined quarter-circular end piers (Models III, IV, and V) with the triangular interior piers of Model I. The spillway rating data are presented in Table 20.

Model VII. Model VII was identical to Model V except that the base of the blunt triangular interior piers was reduced from 8 feet to 7 feet in order to reduce the lateral separation of the spillway jets. Figure 57 shows the details of the interior pier. Table 21 lists the spillway rating data for Model VII.

Model VIII. Model VIII was built according to instructions from SCS. It was characterized by blunt triangular interior piers and by nearly triangular end piers. Details of the interior piers are shown in Figure 58, and details of the end piers are shown in Figure 59. The spillway rating data are shown in Table 22.

Model IX. Rather severe flow separation at the end piers suggested a rounding-off of the end piers by adding a curved piece of sheet metal to Model VIII. Details of the end pier of Model IX are shown in Figure 60. The rating data for Model IX are given in Table 23.

Model X. A further improvement to the spillway model was the

addition of bullet-shaped interior piers to Model IX. Details of the interior pier are shown in Figure 61. The spillway rating data are presented in Table 24.

Model XI. The bullet-shaped interior piers of Models IX and X were retained. The end piers of Models IX and X were more carefully constructed by using plastic pipe sections. Model XI was thus identical to Model X except that a more permanent construction was used in the fabrication of the end piers. The head discharge data are presented in Table 25.

Model XII. In Model XII the double-curvature end piers of Model XI were retained. The interior piers were constructed according to SCS specifications. Figure 62 shows details of the interior piers of Model XII. The head-discharge data are given in Table 26. Water surface profiles were measured on this spillway model for flow rates of 63,700 and 70,600 cubic feet per second. These data are listed and presented graphically as follows:

63,700 cfs	Table 27	Figures 63, 64, 65
70,600 cfs	Table 28	

Model XIII. A review of test results on Models I through XII indicated that the optimum pier shapes were bullet-shaped interior piers (Figure 61) and double-curvature end piers (Figure 60). For a probable maximum flood (PMF) of some 60,000 cfs, the tests also indicated that the required bay width was 30 feet for each of the three bays. Model XIII was built to include the optimum pier shapes, 30-foot bay widths, and 25-foot radius tainter gates. The "Final" model was thus the culmination of a rather lengthy process of experimentation. All subsequent laboratory

tests were conducted on Model XIII.

V. Test Results - The "Final" Model

Model XIII, or the "Final" model, was investigated and tested in a number of ways and for a number of purposes. The results reported in this chapter pertain to

- a. ungated spillway discharge capacity tests,
- b. gated spillway capacity tests,
- c. delineation of hysteresis between gated discharges (partially open tainter gates) and ungated discharges (free-flowing spillway discharge),
- d. flip bucket energy dissipator experiments,
- e. velocities and motion patterns in the tailrace, and
- f. scour patterns downstream from the energy dissipator.

The details of the end piers and the interior piers of the "Final" model are shown in Figure 66, a plan view of the spillway is shown in Figure 67, and an elevation view as shown in Figure 68 includes the tainter gate.

Ungated Spillway Capacities. The initial test sequence was carried out in order to verify the head-discharge relationships postulated for the "Final" model with its 30-foot wide spillway bays. This work was carried out in three stages with emphasis on high discharges, then low discharges, and then additional free-flowing data was gathered during the hysteresis study. Table 29 shows the head-discharge relationships for flows in excess of 30,000 cubic feet per second. For flows of some 40,700 cfs and 60,000 cfs measurements of the water surface profiles were made. Thus, Table 30 lists the water surface elevations for 40,700 cfs, and Table 31 lists the elevations for 60,000. The corresponding profiles are plotted in Figures 69, 70 and 71 for spillway bays No. 1, 2, and 3, respectively, for

$Q = 40,700$, and in Figures 72, 73 and 74 for $Q = 60,000$ cubic feet per second.

For a better definition of the head-discharge relationship at low flows a different laboratory set-up was required. Thus, a separate pump-meter system was calibrated and installed. The system consisted of a centrifugal pump, two-inch diameter PVC piping, a valve and an elbow meter.

A series of tests were then conducted to define the spillway rating at low heads under free overflow conditions. Table 32 shows a summary of the tests for ungated flows at rates less than 15,000 cubic feet per second. The rating curve is presented in Figure 75.

Additional head-discharge data for free overflow conditions were obtained during the hysteresis studies described below. These data could be included in the spillway rating curve for ungated flows. The rating curve for the Lower Reservoir Main Spillway for ungated flows is shown in Figure 76. The rating curve is given in proto-elevation in Lake Oconee versus spillway discharge capacity in cubic feet per second.

Hysteresis Study. The spillway discharges may be controlled by proper operation of the tainter gates. These gated discharges are useful in the operation of the lower reservoir. However, there are no definite limits to the spillway operation as an overflow structure and the spillway operation for gated discharges. The tainter gates are not designed for overflow conditions.

There exist regions of hysteresis in the head-discharge relationships for gated discharges. Typically, during rising discharges and with the

gate positions fixed the accelerating flow patterns result in water surface draw-downs. This draw-down results in free flowing (ungated) spillway discharges which result from the same reservoir level when the tainter gates are submerged. This latter relationship (gated flow) persists longer during falling discharges when the gates are submerged and no appreciable water surface draw-down takes place.

In the laboratory, a series of tests were conducted to delineate typical regions of hysteresis for the Lower Reservoir Main Spillway. For this purpose the three tainter gates were preset to certain gate openings. Then, the flow rates were first incrementally changed to establish carefully the conditions of reservoir elevation and spillway discharge at which the free overflows would be changed into gate-controlled discharges. Subsequently, the flows would be diminished by small decrement in order to establish the prevailing conditions at which the gate controlled flows would be changed to free overflow conditions. Thus, test sequences were conducted both for rising discharges and for falling discharges. The gate openings for which these regions of hysteresis were established were 20 feet, 15 feet, 10 feet and 5 feet.

The laboratory data were organized into tables and a graph to delineate the areas of hysteresis as observed in the hydraulic model. Thus, Table 33 shows the laboratory results for rising discharges when the gate opening was 20 feet. Table 34 shows the results for the same 20-foot gate opening for both the conditions of rising discharges and the conditions of falling discharges. The test results for 15-foot gate openings are shown in Table 35, for 10-foot gate openings in Table 36, and for 5-foot

gate openings in Table 37. Some of the tabulated data indicate that the tainter gates were overtopped before an equilibrium condition could be obtained. A composite of the test data is presented in graphical form in Figure 77. The conditions at which the tainter gates became submerged during rising discharges and became unsubmerged during falling discharges are indicated in Figure 76.

Gate Controlled Flows. Gate controlled flows are discharges from partially open tainter gates. For the normal operation of the Lower Reservoir of the Rocky Mountain Project, programmed releases from the reservoir require prior knowledge of the head-discharge relationships for gate controlled spillway discharges. For this purpose, a sequence of tests were conducted to establish ratings for gate controlled flows. The test results are presented in tables. A summary of the ratings for discharges from partially open tainter gates is presented in Figure 77.

The tainter gates of the Lower Reservoir spillway are to be operated by means of piston-driven ratchets. At the initial gate movements from a closed position, the gates travel in 8-inch increments. Thus, ratings were obtained beginning with 8-inch increments although later on even-foot increments were used in the model tests, and the results can be interpolated fairly accurately for intermittent gate openings. It should be noted also that in view of the 1:40 model scale and in view of some inevitable leakage from the model basin the test data for minimal gate openings are correspondingly less exact than data obtained at higher model flows. In the summary graph in Figure 77 the ratings for minimal gate openings have been adjusted in order to more appropriately reflect actual head-discharge relationships.

The test results in the following tables correspond to actual data.

Since the spillway consists of three 30-foot wide bays, the gate openings are coded for each test sequence. For example, gate openings of 0-5-0 designated that the tainter gates in Bays No. 1 and No. 3 were closed and that the gate in Bay No. 2 was tested with a gate opening of five feet. A summary of the test conditions is presented below.

Summary of Ratings of
Gate Controlled Flows

<u>Table Number</u>	<u>Gate Openings</u>
38	0 - 8 - 0 (inches)
39	8 - 8 - 8 (inches)
40	16 - 16 - 16 (inches)
41	0 - 24 - 0 (inches)
42	0 - 32 - 0 (inches)
43	0 - 48 - 0 (inches)
44	0 - 4 - 0 (feet)
45	0 - 5 - 0 (feet)
46	1 - 5 - 1 (feet)
47	2 - 5 - 2 (feet)
48	3 - 5 - 3 (feet)
49	4 - 5 - 4 (feet)
50	5 - 5 - 5 (feet)
51	10 - 10 - 10 (feet)
52	15 - 15 - 15 (feet)
53	20 - 20 - 20 (feet)

At large gate openings there was considerable eddying motion adjacent to the piers and intermittent air entrainment. Although the laboratory observations precluded such verifications the unsteady nature of gated discharges at gate openings of 15 feet, and larger, may result in

undesirable gate vibrations. Also, in the laboratory with its limited storage capacity in the model reservoir the gates were often overtopped after relatively small increments in discharges. The tests were terminated when overtopping occurred.

VI. The Energy Dissipator

The design of spillways for adequate emergency discharges is paramount to sound engineering practice. As the discharges proceed over the spillway into the valley below the dam, very high velocities develop and some form of energy dissipator is necessary to prevent the occurrence of excessive scour and scour damage. In the Rocky Mountain Project a bucket type dissipator was proposed which will project the high velocity spillway discharge into the tailrace some distance downstream from the toe of the spillway. Depending on the thickness of the overburden in the tailrace and depending on the soundness of the underlying bedrock the water issuing from the spillway will create a scour hole in the tailrace. Ultimately, a condition of equilibrium is reached in which no further scour takes place and materials entrained in the scour hole are deposited on its slopes and subsequently slide back to the bottom.

The location and size of the scour hole depends also on the geometry of the bucket type energy dissipator and on the prevailing tailwater elevations. The tailwater conditions are particularly important since the energy dissipation can be greatly assisted by a hydraulic jump. At any rate, pools at the toe of the spillway may endanger the structure, the guidewalls and possibly the embankments. Hydraulic model studies were carried out to provide design information for the bucket type energy dissipator, for the guidewalls, and to check for the dissipator's effectiveness. Velocity distributions were measured in the tailrace. The movable bed model basin was also suited to provide information on scour patterns in the tailrace and at the earth embankment

to the left (north side) of the spillway.

The model had been built to allow for a number of changes in the bucket geometry and in the guidewall geometry. The initial tests were made with a 35-foot radius bucket. The bucket invert elevation was at 635 feet. The guidewalls were flared at 5 degrees. Later on, the bucket was set at an invert elevation of 630 feet, and a variety of bucket geometries and guidewall geometries were investigated. A summary of the test conditions are listed in Table 54.

The initial test series were made with the bucket dissipator with its invert at 635 feet, with an exit angle of 45 degrees, with an exit lip elevation of 646 feet, and with a flare angle of 5 degrees. A vertical view of the dissipator is shown in Figure 78, a horizontal view is shown in Figure 79. In order to assess the performance of the dissipator the height of the jet trajectory was measured, as was the impact distance downstream from the end of the bucket. The heights were reported relative to the bucket invert elevation of 635 feet. Two different heights were observed and recorded. A maximum height corresponded to the "rooster tail" effects and the minimum height corresponded to the areas in between the "rooster tails" There were two "rooster tails" in line with and downstream from the two interior spillway piers. Table 55 lists the performance characteristics for the range of discharges investigated.

Velocity distributions in the tailrace were also measured for spillway discharges of 30,000 and 60,000 cubic feet per second. The velocities were measured some five feet below tailwater surface. The measuring stations are shown in the definition sketch of Figure 80.

Table 56 and Table 57 list the velocity distributions in feet per second (prototype). For these tests the flare angle was 7.5 degrees.

Similar tests were carried out with a modified bucket with an exit angle of 37.5 degrees, and with exit lip elevations of 642 feet and 646 feet. The guidewall flare angle was maintained at 7.5 degrees. Figure 81 shows the respective bucket geometries. Table 58 shows the bucket performance characteristics for the range of spillway discharges investigated.

Velocity distributions in the tailrace were measured for discharges of 30,000 and 60,000 cubic feet per second at exit lip elevations of 642 feet and 646 feet, respectively. The velocities were measured at stations as defined in Figure 80 and at five feet below the tailwater surface. Tables 59, 60, 61 and 62 list the velocity distributions in the tailrace for the above test conditions.

Another bucket modification was made in which the exit lip angle was 30 degrees. An elevation sketch is shown in Figure 82. The bucket performance characteristics are listed in Table 63. Velocity distributions in the tailrace were obtained for flows of 30,000 and 60,000 cubic feet per second and for exit lip elevations of 640, 642, and 646 feet, respectively. The velocity distributions are listed in Tables 64 through 69.

When the guidewall flare angle was changed from 5 degrees to 7.5 degrees, no significant changes in flow patterns were observed. The relatively large residual velocities indicated that a lowering of the bucket invert would provide greater submergence of the bucket discharges and hence a concomitant increase of energy dissipation through the action

of the hydraulic jump conditions. Also, the test results indicated more favorable performance characteristics at lower exit lip angles. Subsequently, the bucket invert elevation was lowered to an elevation of 630 feet and the bucket curvature was terminated at the invert and replaced by ramps of inclinations of 0, 10, 20, and 30 degrees. The tested geometries are shown in Figures 83, 84, and 85 for the lowered spillway bucket, and in Figures 86, 87, 88 and 89 for the ramped exit configurations. The "ramped" buckets were judged satisfactory even at an exit angle of zero degrees in which all of the energy dissipation was due to the hydraulic jump conditions. Best conditions were obtained with an invert elevation of 630 feet, with a ramp inclination of ten degrees, and with an exit lip elevation of 637 feet. The "best" conditions were judged on the basis that the "rooster tails" were confined within the guidewalls and that the hydraulic jump occurred mostly on the ramp and within the lengths of the guidewalls.

The elevation of the guidewall was variously set at 655 feet, 665 feet and 667 feet. At the lower elevations flow would take place over the guidewalls whenever the tailwater elevation exceeded the height of the guidewalls. Although this crossflow seemed to assist the hydraulic jump, there were indications at high spillway discharges that at the north earth embankment strong return flow patterns may cause erosional damage. Figure 90 shows an elevation sketch of the wingwalls. In later tests the wingwalls were maintained at an elevation of 667 feet which would eliminate the crossflow over the wingwalls and would reduce the danger of erosional damage to the north earth embankment.

Originally, the guidewall flare angles were tested at 5 and 7.5 degrees in order to minimize the flow separations from the walls under supercritical flow conditions. However, it was observed that improved flow conditions in the stilling area downstream from the end of the bucket and in the tailrace beyond was possible by a more rapid expansion of the guidewalls at the end of the bucket. The model observations showed that this rapid expansion in the mostly subcritical flow region encouraged return flows at the edges along the guidewalls and that return flow patterns assisted in the formation of the hydraulic jump.

A series of tests were then conducted in which a 10 degree ramp was flanked by guidewalls at an elevation of 667 feet. The wingwalls were flared 7.5 degrees on the spillway and the change to a more rapid flare angle took place at the end of the bucket ramp. The tested wingwall geometries are shown in Figure 91 for continuous flare angle of 7.5 degrees. Figure 92 shows a flare angle of 15 degrees in the guidewalls beyond the end of the bucket dissipator. Figure 93 shows a flare angle of 22.5 degrees, Figure 94 shows a flare angle of 30 degrees and Figure 95 shows a flare angle of 30 degrees but with elongated guidewalls. The tests showed that "best" results were obtained with a 30 degree flare angle and with elongated guidewalls.

In order to quantitatively reinforce the above observations two series of tests were conducted. For these tests the ramp angle was 10 degrees, the guidewalls were at flare angles of 30 degrees and their heights at elevation 667 feet. However, in one series the guidewalls were at the "original" length as shown in Figure 94, and in the other test series the guidewalls were extended as shown in Figure 95. For the

test series water surface elevations were measured both inside the stilling basin and at the backsides of the guidewalls. When the water surface elevations reached the tailwater elevations the transition from supercritical to subcritical flow had essentially taken place.

For the "original" length of guidewalls the test results are listed in Tables 70 for $Q = 20,000$ cfs, in Table 71 for $Q = 30,000$ cfs, in Table 73 for $Q = 60,000$ cfs. Except for highest discharges, the hydraulic jumps occurred within the extent of the "original" guidewalls. At the PMF conditions of some 60,000 cfs there were very strong return flow patterns along the north bank of the tailrace and on portions of the north earth embankment. Scour damage was apparent at the end of the north guidewall and at the adjacent toe of the north embankment. It then became obvious that an extension of the guidewall would remove the potentially scour-producing flow patterns further from the north earth embankment. The flow patterns at the south bank of the tailrace were considerably different and no similar scour damage was indicated.

The guidewalls were then extended by approximately 40 feet and the test sequences were then repeated. The water surface elevations were again measured at the indicated locations some 20 feet from the face of the walls. Negative distances are in feet upstream from the end of the bucket, positive distances are measured in feet downstream from the bucket and along the flared walls. The indication of N/A designates an inassessible position and the indication N.F. designates either insufficient depth of flow or model velocities too low to be measured with a midget current meter. The listed test results also show estimated wave height at the guidewalls and at the banks of the tailrace in the

proximity of the dissipator structure, and the degree of wave splash over the guidewalls. Table 74 lists the test results for a spillway discharge of 30,000 cfs and Table 75 lists test results for $Q = 35,000$ cfs. Table 76 and Table 77 list test results for $Q = 45,000$ and 60,000 cfs, respectively. It should be noted that at higher discharges there are the significantly strong return flow patterns within the stilling basin which assist in the energy dissipation and which may also entrain bedload materials and carry them toward the dissipator bucket. In the laboratory model, however, any artificially introduced stone was inevitably transported downstream and no residual stones were found on the ramp after the tests were terminated.

Based on the above observations and measurements the performance characteristics of the bucket type energy dissipator seemed to perform satisfactorily. A further verification was obtained by measurements of velocities in the tailrace. The velocities were measured at stations as shown in Figure 80 and at elevations below the tailwater surface as indicated in the tables of results. Thus, Table 78 shows the velocity distribution in the tailrace for a spillway discharge of 20,000 cfs, Table 79 lists test results for $Q = 30,000$ cfs, Table 80 lists test results for $Q = 45,000$ cfs, and Table 81 lists test results for $Q = 60,000$ cfs.

For the maximum flow rate of 60,000 cfs there was considerable scour damage at the end of the north guidewall. However, in the laboratory model the wall was founded on erodible material and thus the observation may not be significant. No erosional damage occurred at the toe of the north earth embankment. Some erosional damage was evident at both banks

in the tailrace when the PMF discharge was allowed to persist for an approximate prototype time of some eight hours. The channel bed was subsequently reconstituted to conform to a flood plain elevation of 640 feet and the same eight hour flood was allowed to scour in the tailrace of the erodible bed model. The resulting scour hole is shown in Figure 96. During this particular flood test sequence, the scour around the end of the north guidewall did not undermine the wall even though it was again founded on erodible materials. The comments in Table 81 on the undermining of the wingwall pertained to an observation of scour damage resulting from "several" and prolonged "probable maximum floods."

VII. Summary and Conclusions

This report represents the Final Report on Hydraulic Model Studies for the Lower Reservoir Main Spillway of the Rocky Mountain pumped storage hydroelectric project of the Georgia Power Company. The studies were conducted under contract with the Southern Company Services, Incorporated, of Birmingham, Alabama.

The studies proceeded essentially in accordance with the itemized list of objectives as outlined in Chapter II, page 3, of this report. In the progress of the studies results were forwarded to Southern Services, sometimes with recommendations and sometimes with requests for additional instructions. While the model studies were in progress site investigations and foundation explorations were also carried out by other parties. As a result of these specific site studies the location of the lower reservoir dam was moved which necessitated also changes in the laboratory installation.

The spillway geometry was tested with some thirteen different configurations. Eventually, a "final" spillway design evolved which was then thoroughly tested. The results of these tests are presented in Chapters IV for the preliminary models, and in Chapter V for the "final" model. A significant result of the spillway crest modeling was a reduction of the required bay widths of 33 feet for each of the three spillway openings to widths of 30 feet each.

The choices leading up to the "final" model were guided by improved flow patterns on the spillway. These patterns desired included a lessening of flow separation from the piers and a lessening of "lift off"

of the spillway discharges at large flows. The geometry of the piers for the spillway (Model XIII) is shown in Figures 66 and 67. Figure 68 locates the tainter gate on the spillway and on the supporting piers.

Water surface profiles were established for the spillway under various conditions of discharges. For the "final" spillway, the profiles are plotted in Figures 69 through 74. These test results are also listed in Tables 30 and 31.

Ungated spillway discharges were investigated at different times for high rates of flow and for low rates of flow. The lower flow calibrations required a modification of the model water supply system. The spillway discharge calibrations are presented in Tables 29 (high Q) and 32 (low Q).

After the tainter gates had been installed an extensive series of spillway calibrations were made for various gate openings at various rates of discharges. The gate openings were always the normal distances between the spillway surface and the lip of the tainter gates. A given series of tests was terminated when one or more gates were topped by the rising reservoir water surface elevations. At the regions of flow between ungated spillway discharges and gate-controlled flows different relationships between reservoir elevations and discharge capacities were encountered during rising and falling floods. This condition of hysteresis was separately studied and reported in Chapter V, pages 15-17. A summary of test conditions for gated (or gate-controlled) discharges is found on page 18 of this report. A summary plot of all spillway discharge calibrations is presented in Figure 77. The area of uncertainty (hysteresis)

is shaded. Figure 76 shows the conditions encountered in the laboratory hysteresis studies. During the very lowest gate opening tests, an additional uncertainty regarding the actual laboratory flow rates existed because of leakage from the model. For this reason the lowest rating curves were dashed into the comprehensive plot of Figure 77. The reservoir elevations at which the gates were overtopped and at which a given test sequence was terminated are also shown in Figure 77.

A considerable effort was made to provide for adequate energy dissipation in the project by means of a bucket type dissipator. A variety of geometries were investigated. A summary of the test geometries is given in Table 54. Ultimately, the most satisfactory results were obtained when the bucket invert was lowered by five feet and when a ten degree ramp was placed at the terminal end of the dissipator. The ten degree ramp was tested with end lip elevations of 637.5 feet and 640 feet with satisfactory results. An end lip elevation of about 637 feet may be satisfactory to prevent debris from the tailrace to be entrained onto the bucket type dissipator. During these tests the effectiveness of the dissipator was evaluated on the basis of the resulting flow patterns in the tailrace and on the basis of protection against scour at the north earth embankment.

The above design objectives were met when the guidewalls of the stilling basin were flared at an angle of 30 degrees from the axial centerline, when the height of the guidewalls were at the elevation associated with the tailwater elevation of the maximum flood (667 feet),

and when the walls were extended some 40 feet beyond the originally proposed dimension. Figure 95 presents a plan view of the recommended guidewall geometry.

The tailwater rating curve had been developed by personnel of Southern Services. In the model tests this rating was used as a "nominal" rating curve. Invariably, the dissipator performance was also tested at tailwater elevations some two feet above the "nominal" water surface elevations and at two feet below the "nominal" elevations. At the higher elevation as well as at the lower elevations the dissipator performed satisfactorily. Naturally the higher tailwater elevations tended to provide additional dissipation as the jump was moved more onto the bucket ramp. The lowered tailwater elevations had the opposite effect. However, within the two-foot margins investigated the dissipator performed well. The model scale (1:40) prevented the development of "white water." The actual prototype performance with its highly air-entrained flows will experience higher turbulence levels and greater energy dissipation which can be taken as an additional factor of safety.

In the final experiments the movable bed tailrace model was investigated for potential scour patterns. The bed materials were uniform, non-cohesive, fine gravel of some one-eighth inch in diameter. However, the correlation of the laboratory scour pattern and the potential scour in the tailrace of the Rocky Mountain Project is not too well established. In the laboratory the erodible bed was scoured to a depth of some 30 feet below the nominal rock surface elevation in the tailrace. Even so, the toe of the earth embankment on the northside of the spillway was not scoured.

Thus, it can be concluded on the basis of the laboratory experiments that the structural integrity of the earth embankment is assured.

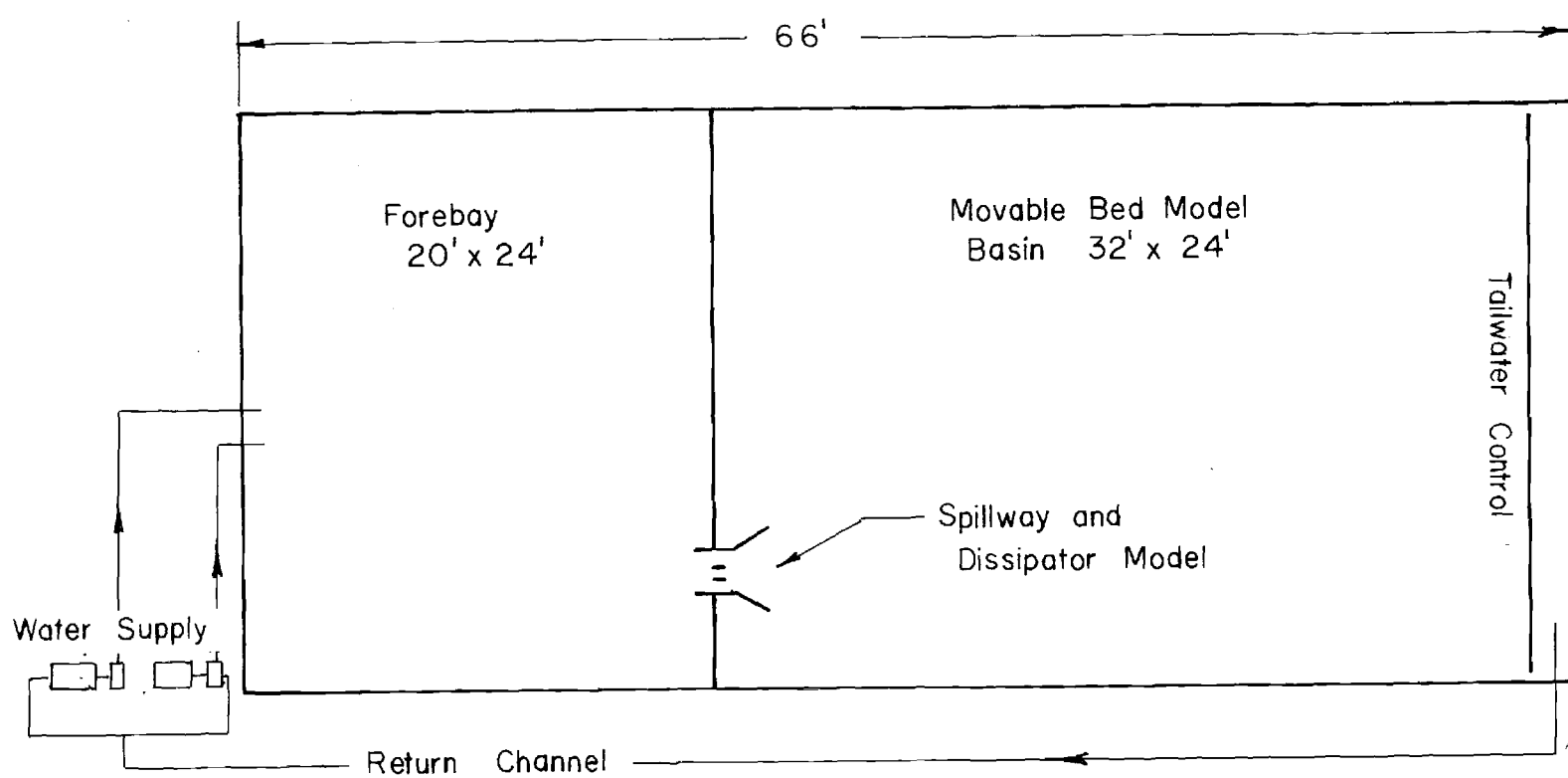

Figure 1.
ROCKY MOUNTAIN PROJECT
MAIN SPILLWAY MODEL STUDY
1:40 Scale Model
LABORATORY SCHEMATIC

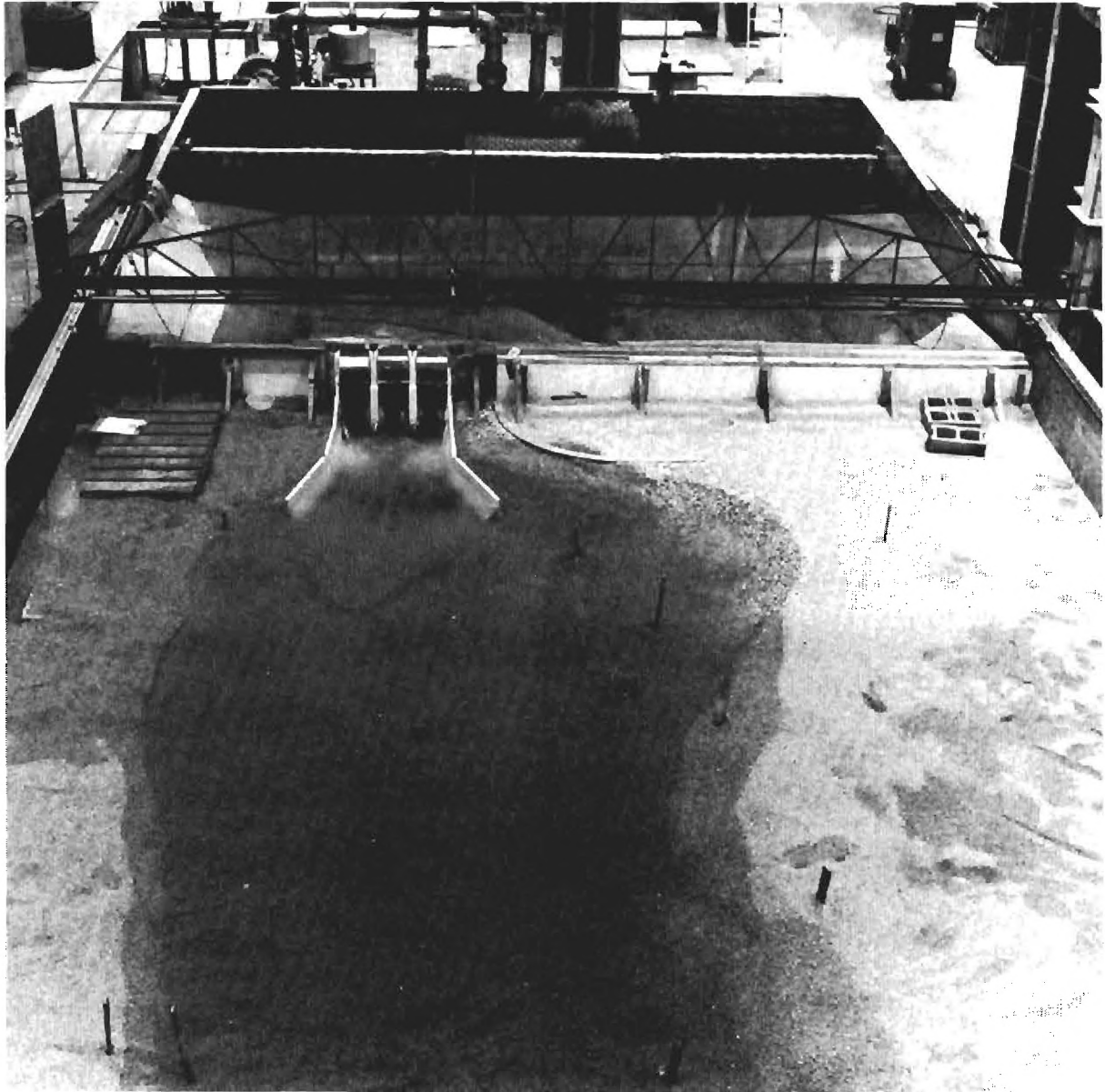

Figure 2.
ROCKY MOUNTAIN PROJECT
MAIN SPILLWAY MODEL STUDY
1:40 SCALE MODEL

BIRDS-EYE VIEW OF SPILLWAY MODEL IN LABORATORY



FIGURE 3.
ROCKY MOUNTAIN PROJECT
MAIN SPILLWAY MODEL STUDY
1:40 SCALE MODEL

OBLIQUE VIEW OF SPILLWAY MODEL IN LABORATORY

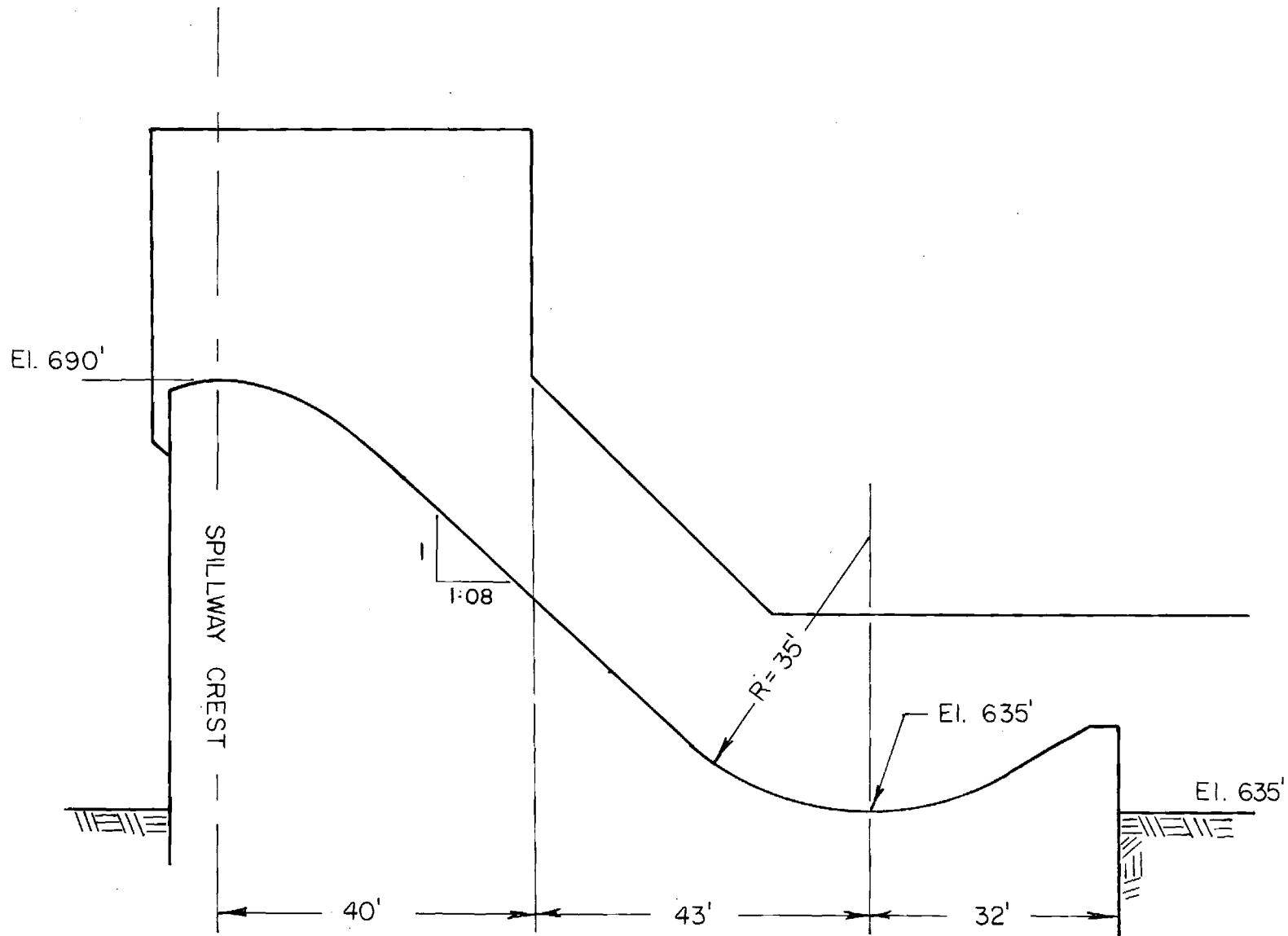

FIGURE 4.
ROCKY MOUNTAIN PROJECT
MAIN SPILLWAY MODEL STUDY
1:40 SCALE MODEL

TYPICAL VERTICAL CROSS-SECTION

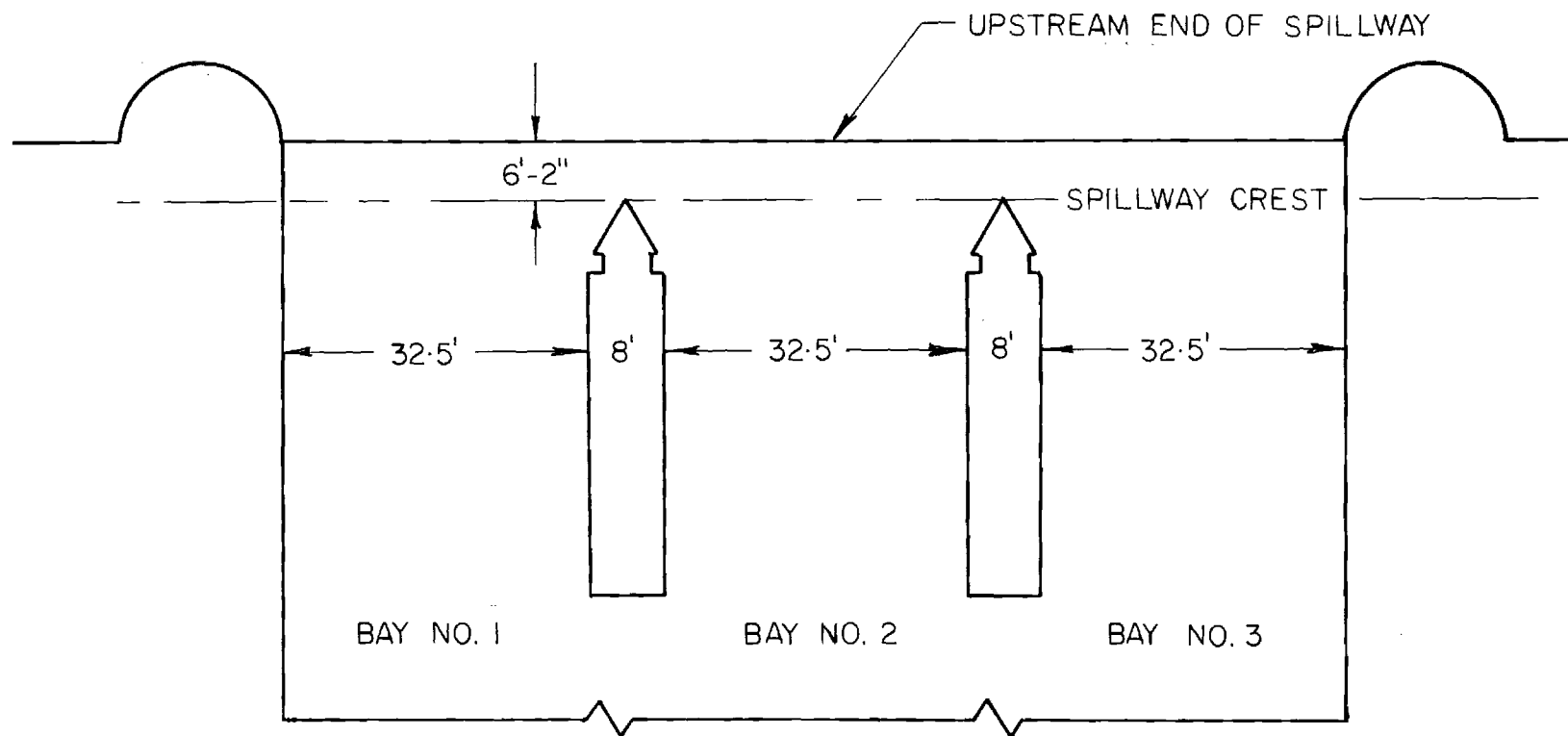

FIGURE 5.
ROCKY MOUNTAIN PROJECT
MAIN SPILLWAY MODEL STUDY
1:40 SCALE MODEL

TYPICAL HORIZONTAL SECTION

For 32.5' width bays,
 $a = 7.5'$
 $b = 1.25'$

For 30' width bays,
 $a = 4.8'$
 $b = 5.1'$

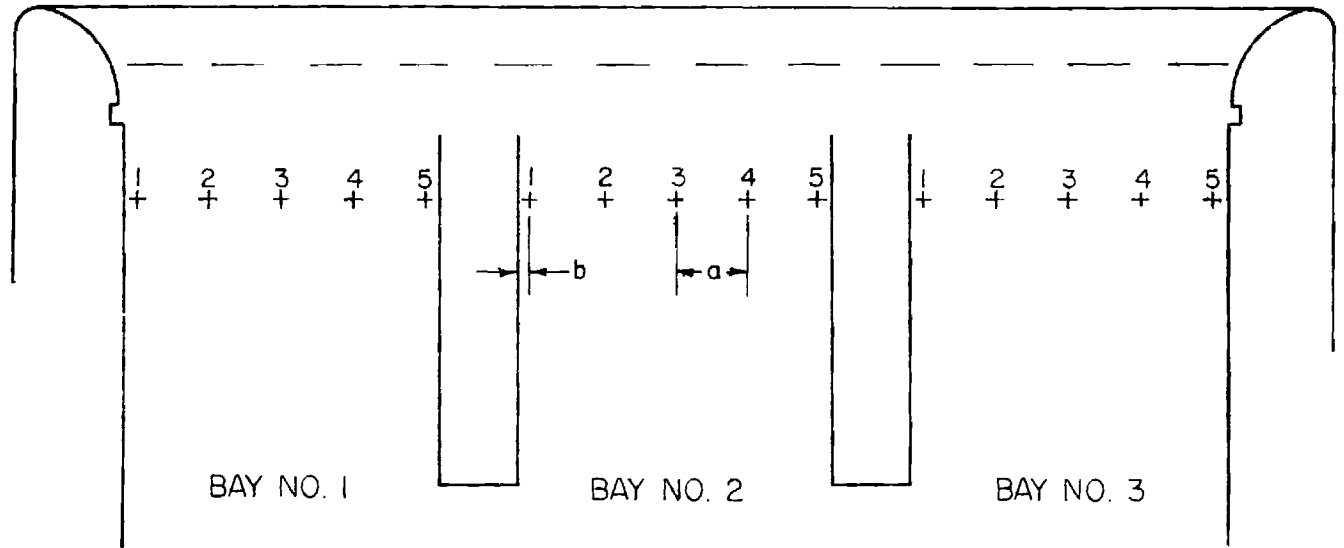

FIGURE 6.
ROCKY MOUNTAIN PROJECT
MAIN SPILLWAY MODEL STUDY
1:40 SCALE MODEL

NAPPE PROFILE, DEFINITION SKETCH

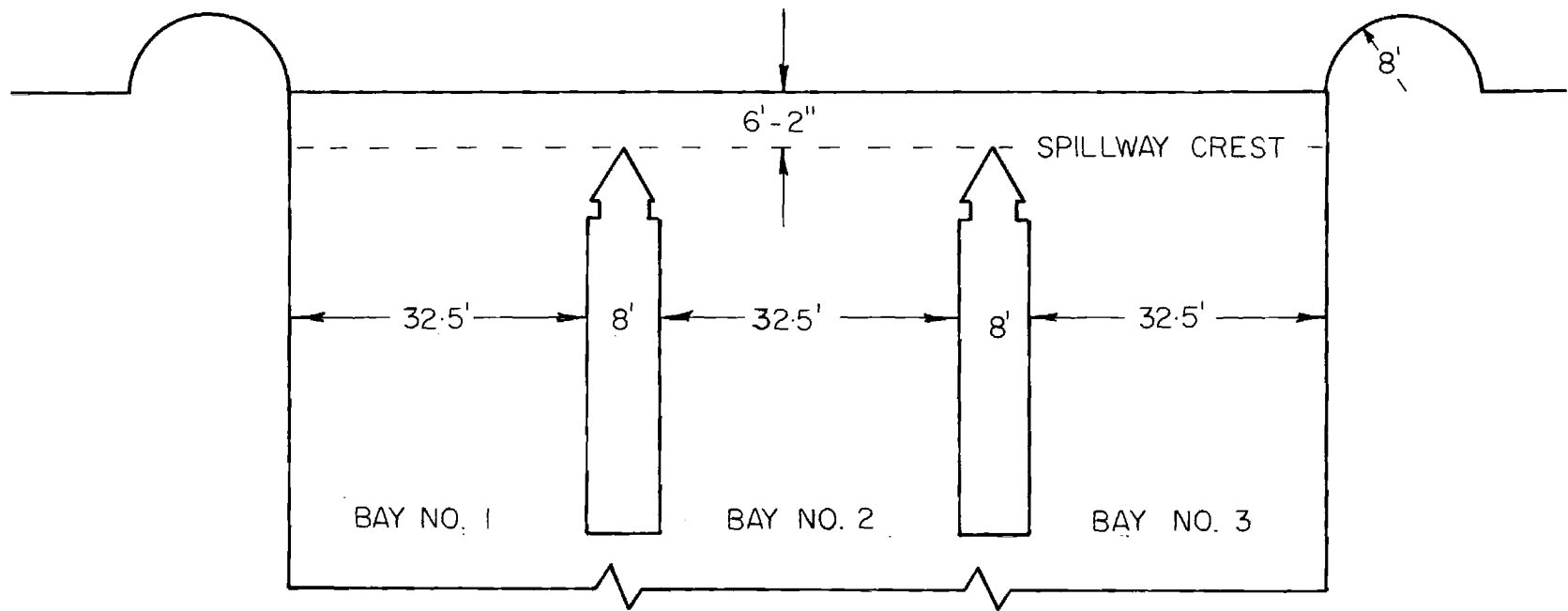

FIGURE 7.
ROCKY MOUNTAIN PROJECT
MAIN SPILLWAY MODEL STUDY
1:40 SCALE MODEL

MODEL I, PLAN VIEW

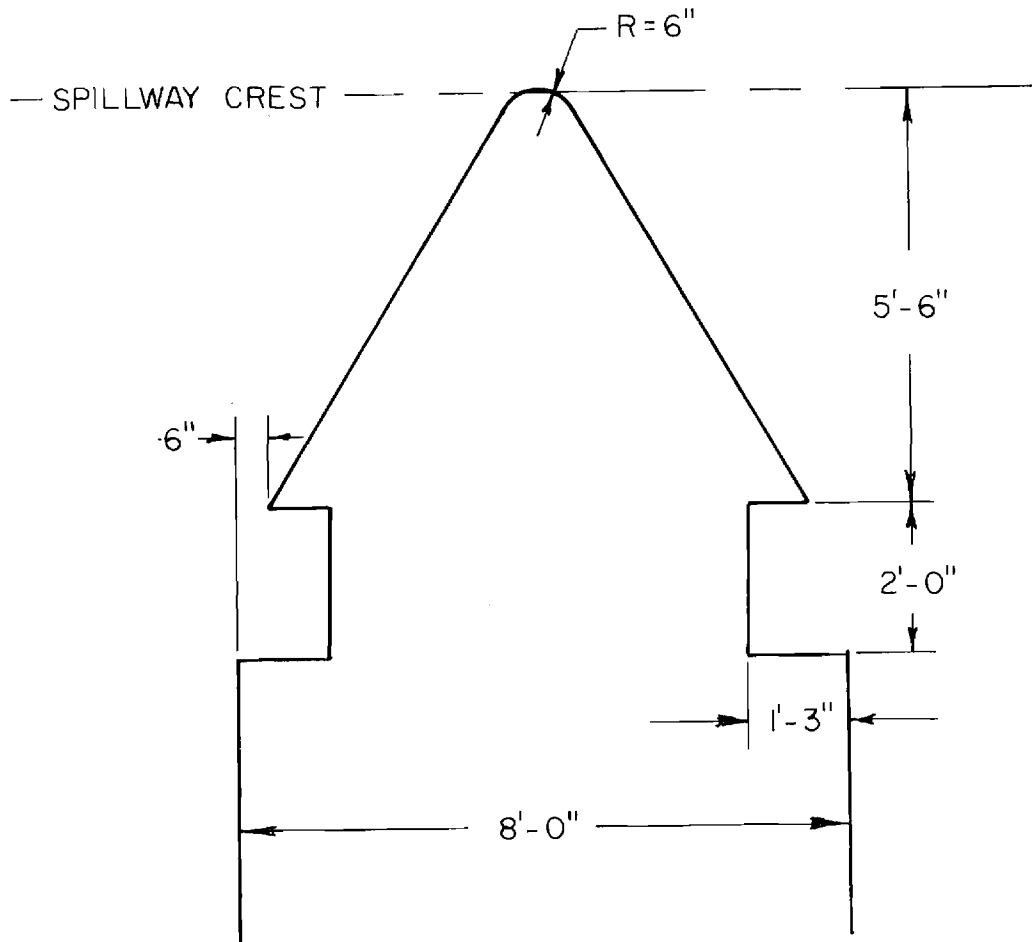

FIGURE 8.
 ROCKY MOUNTAIN PROJECT
 MAIN SPILLWAY MODEL STUDY
 1:40 SCALE MODEL

MODEL I, DETAIL OF INTERIOR PIER

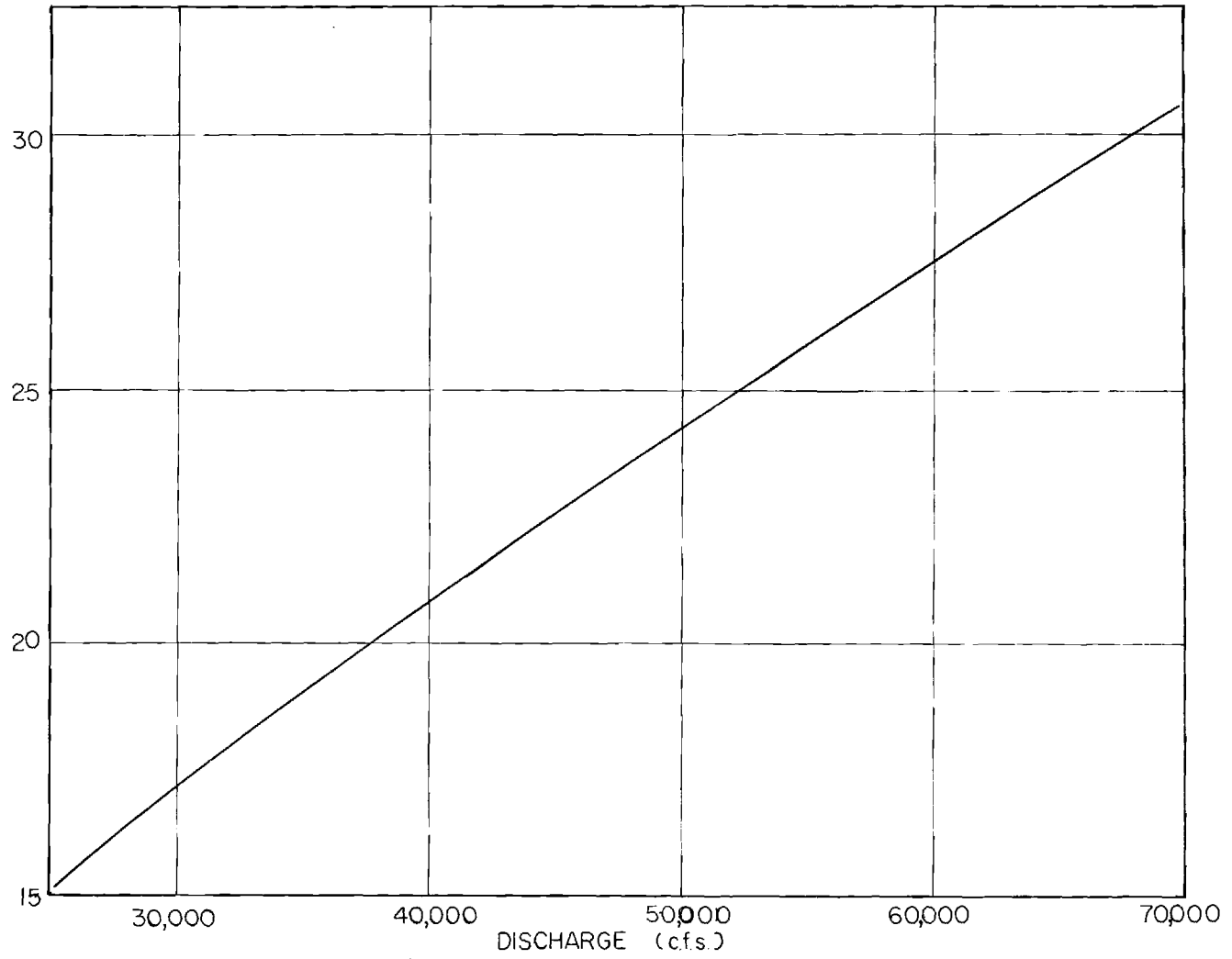

FIGURE 9.
ROCKY MOUNTAIN PROJECT
MAIN SPILLWAY MODEL STUDY
1:40 SCALE MODEL

MODEL I, SPILLWAY RATING CURVE

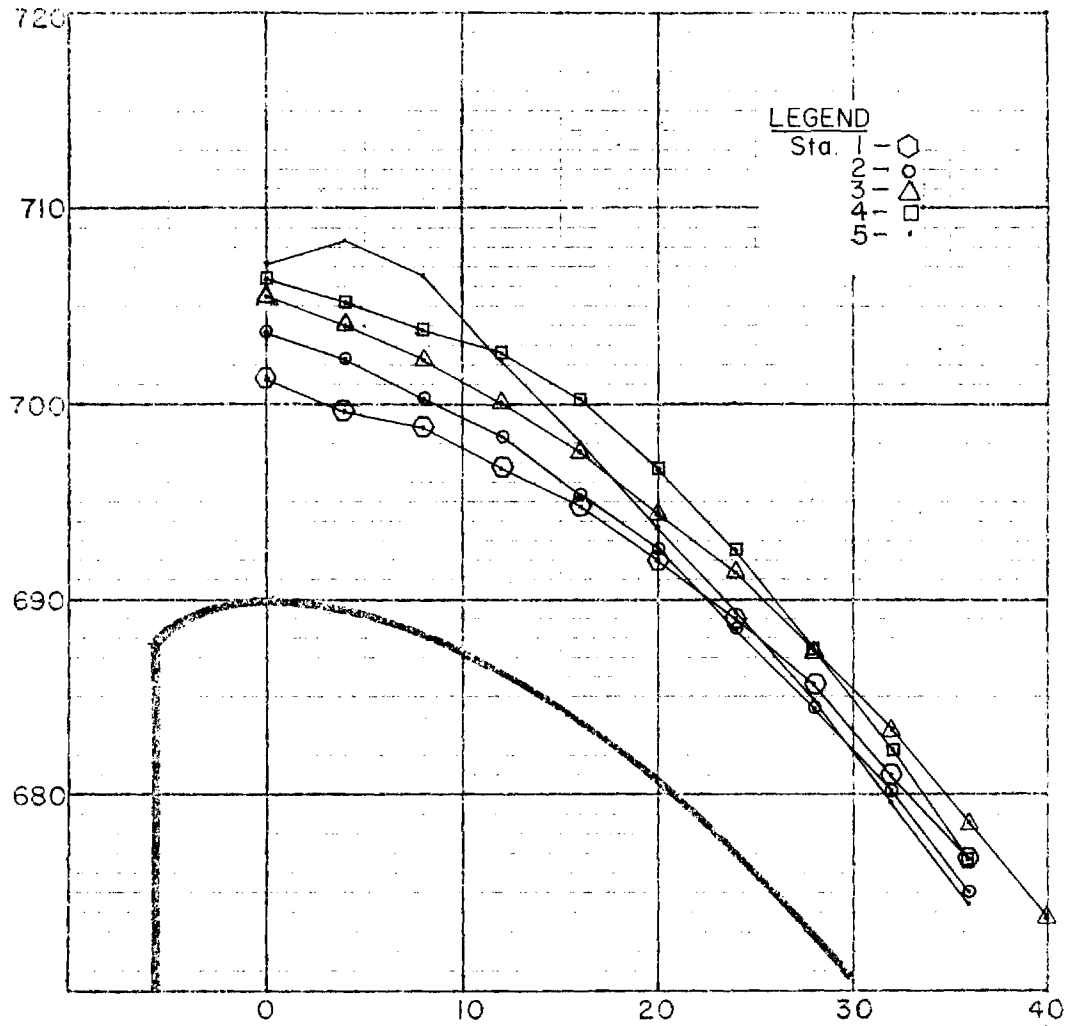

FIGURE 10.
 ROCKY MOUNTAIN PROJECT
 MAIN SPILLWAY MODEL STUDY
 1:40 SCALE MODEL

MODEL I, WATER SURFACE PROFILE

BAY NO. 1
 Q = 40,000 c.f.s.
 Res. El. = 710.8'

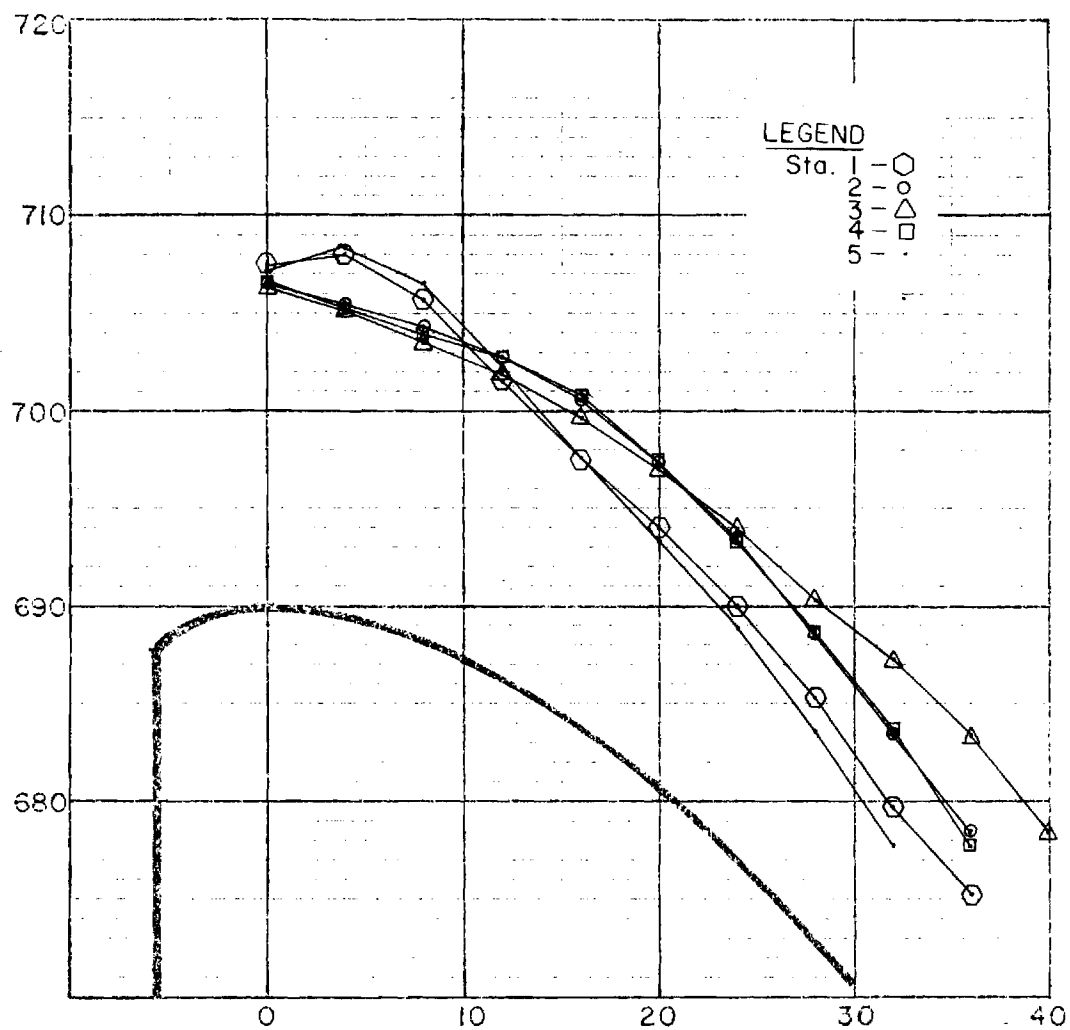

FIGURE II.
 ROCKY MOUNTAIN PROJECT
 MAIN SPILLWAY MODEL STUDY
 1:40 SCALE MODEL

MODEL I, WATER SURFACE PROFILE

BAY NO. 2
 Q = 40,000 cfs.
 Res. El. = 710.8'

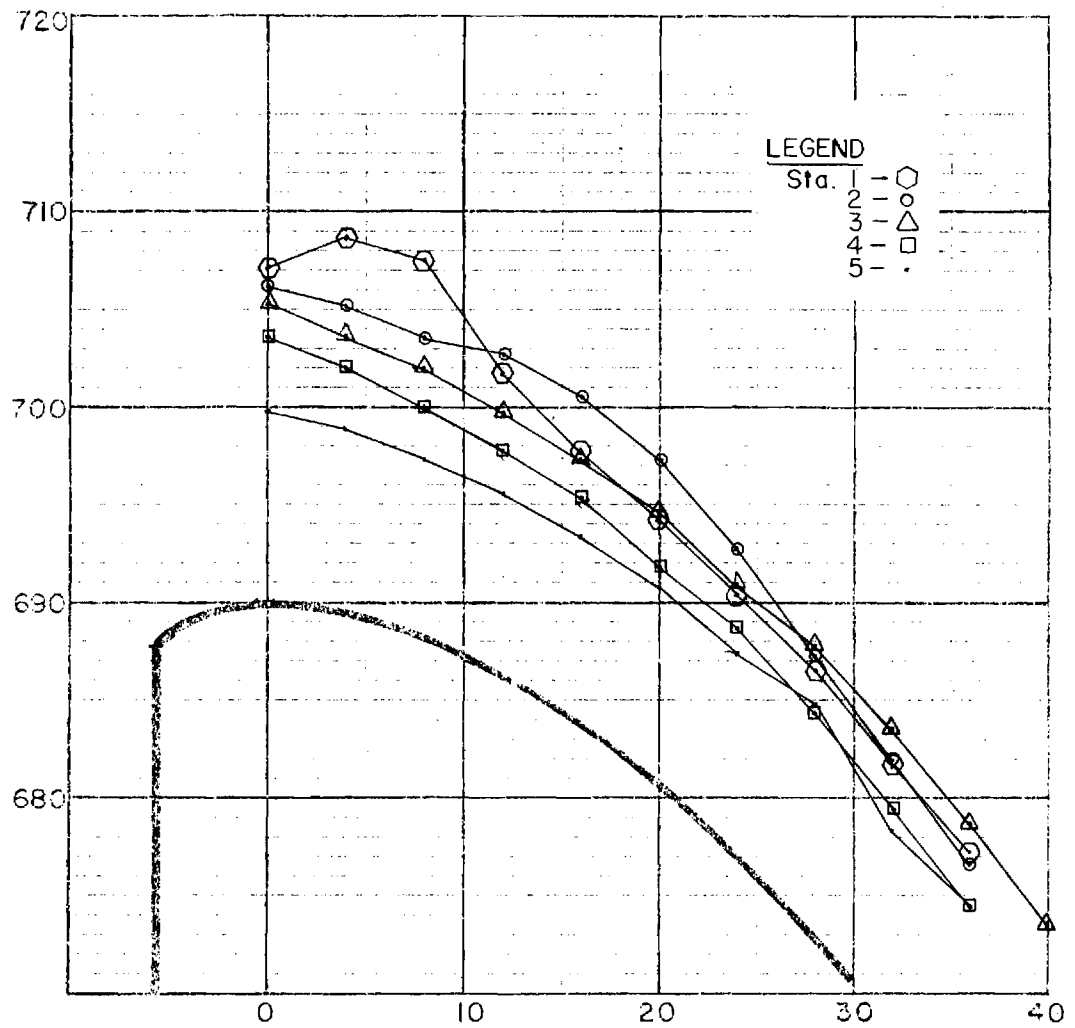

FIGURE 12.
 ROCKY MOUNTAIN PROJECT
 MAIN SPILLWAY MODEL STUDY
 1:40 SCALE MODEL

MODEL I, WATER SURFACE PROFILE

BAY NO. 3
 Q = 40,000 c.f.s.
 Res. El. = 710.8'

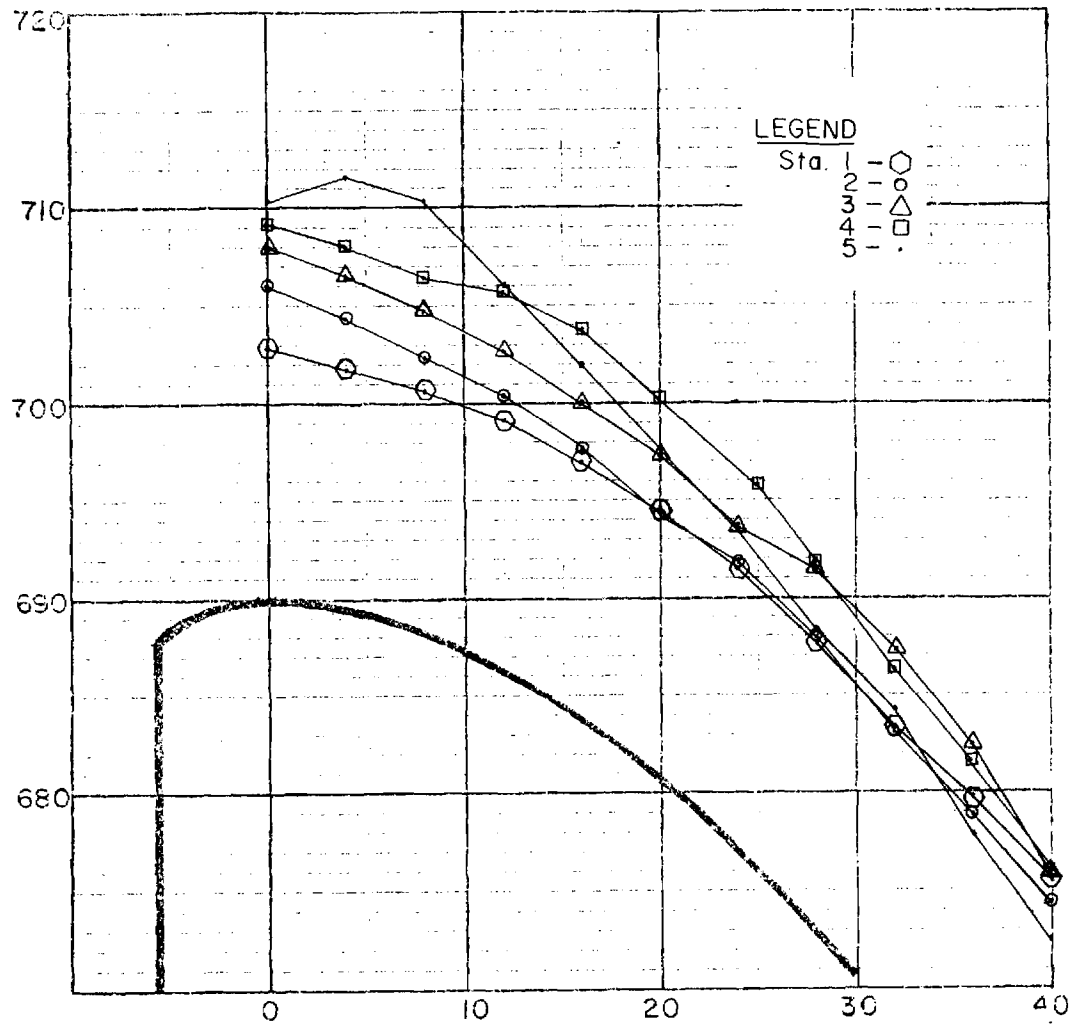

FIGURE 13.
 ROCKY MOUNTAIN PROJECT
 MAIN SPILLWAY MODEL STUDY
 1:40 SCALE MODEL

MODEL I, WATER SURFACE PROFILE

BAY NO. 1
 Q = 50,000 c.f.s.
 Res. El. = 714.3'

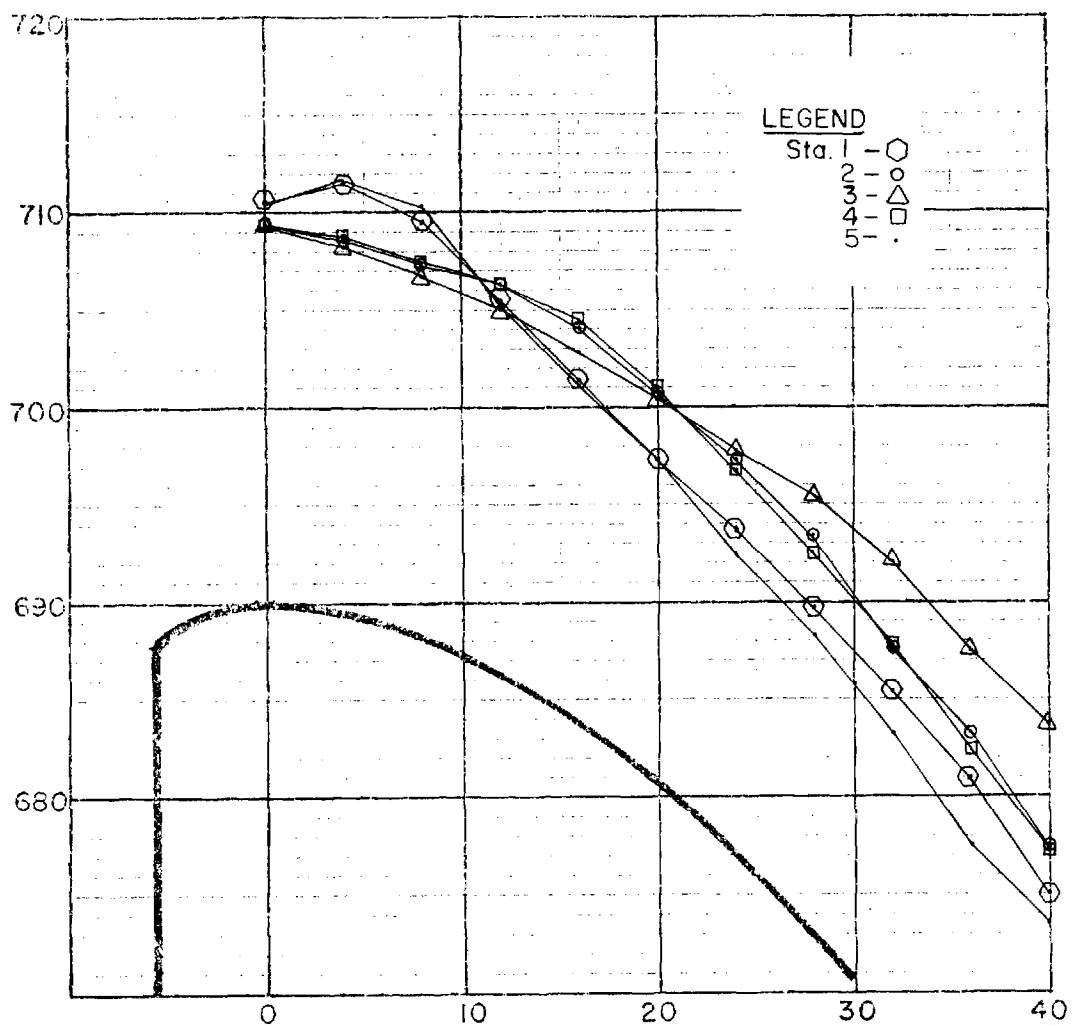

FIGURE 14.
 ROCKY MOUNTAIN PROJECT
 MAIN SPILLWAY MODEL STUDY
 1:40 SCALE MODEL

MODEL I, WATER SURFACE PROFILE

BAY NO. 2
 Q=50,000 c.f.s.
 Res. El. = 714.3'

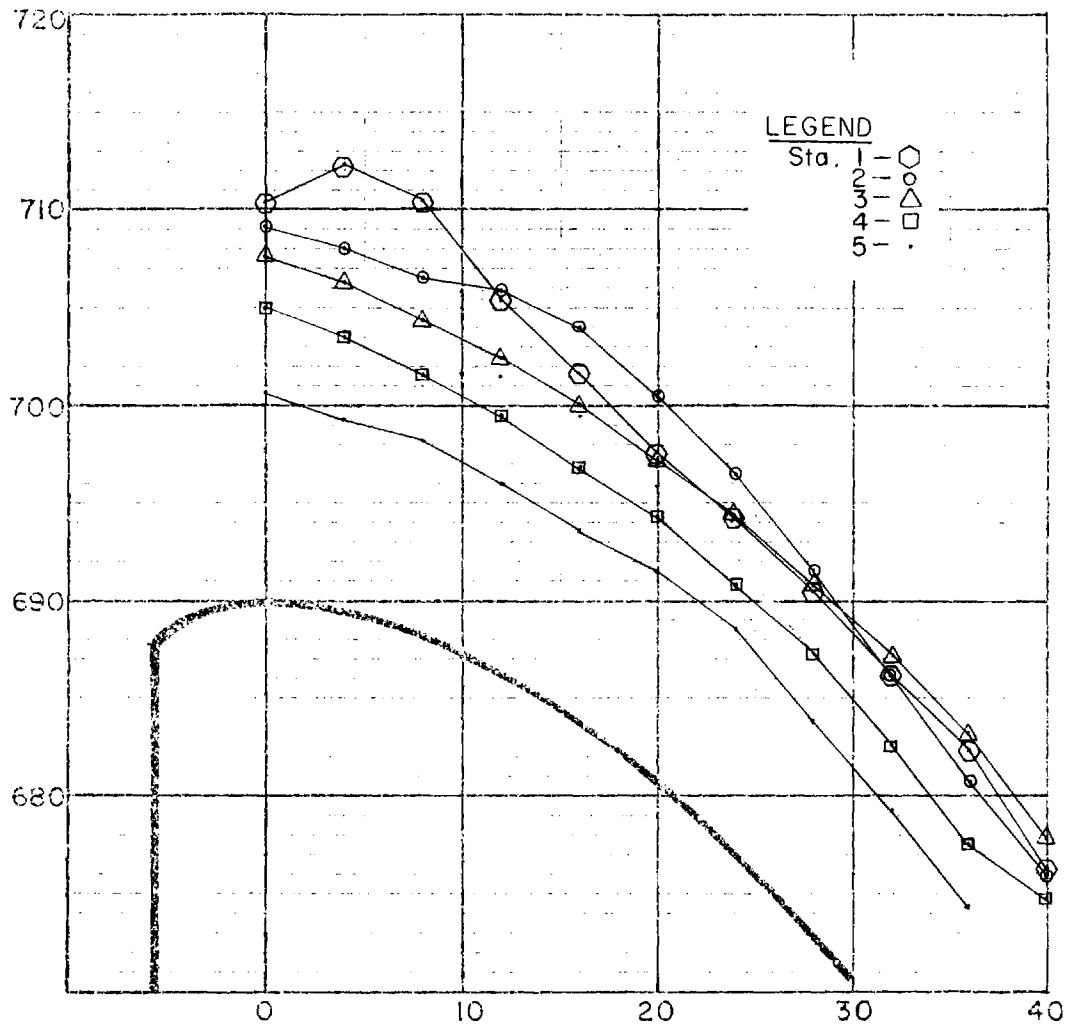

FIGURE 15.
 ROCKY MOUNTAIN PROJECT
 MAIN SPILLWAY MODEL STUDY
 1:40 SCALE MODEL

MODEL I, WATER SURFACE PROFILE

BAY NO. 3
 Q = 50,000 c.f.s.
 Res. El. = 714.3'

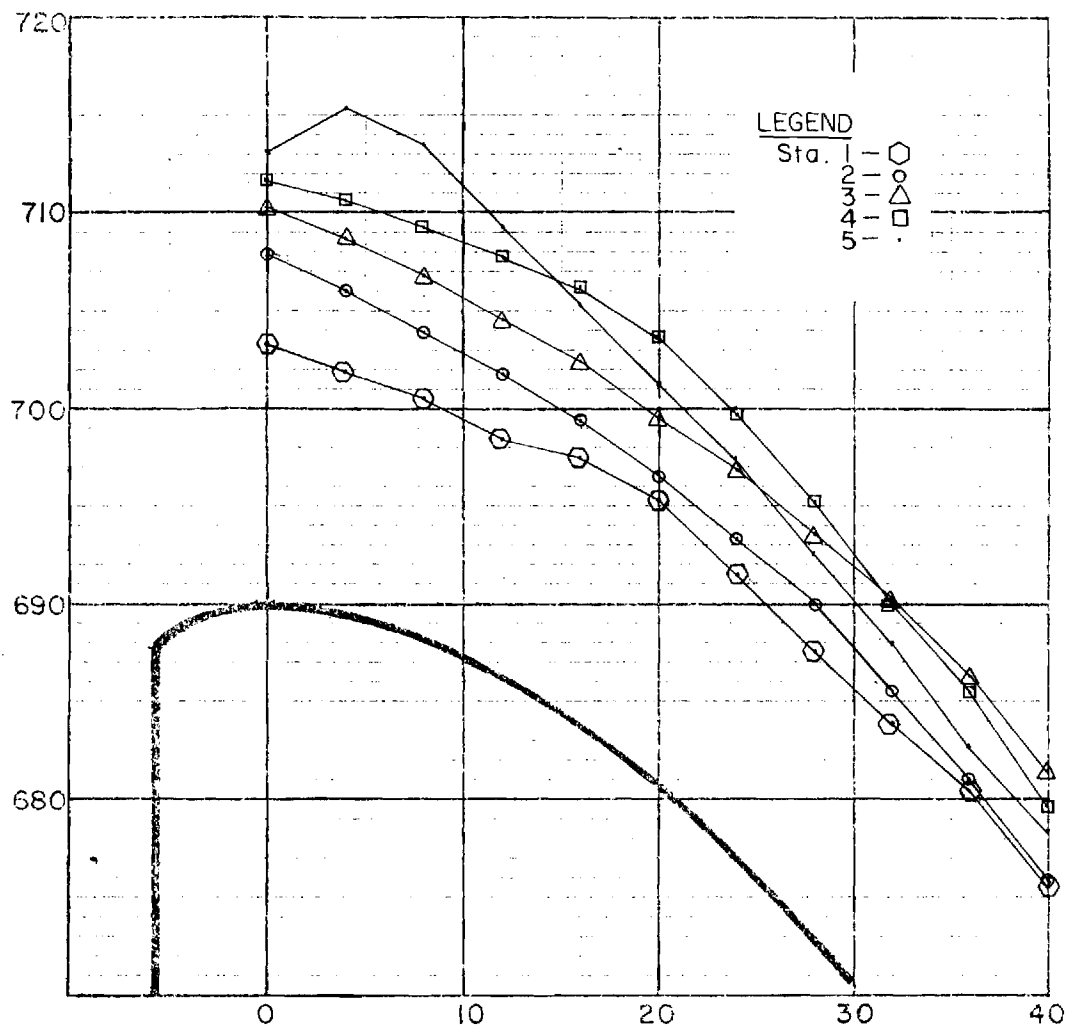

FIGURE 16.
 ROCKY MOUNTAIN PROJECT
 MAIN SPILLWAY MODEL STUDY
 1:40 SCALE MODEL

MODEL I, WATER SURFACE PROFILE

BAY NO. 1
 Q = 60,000 c.f.s.
 Res. El. = 717.5'

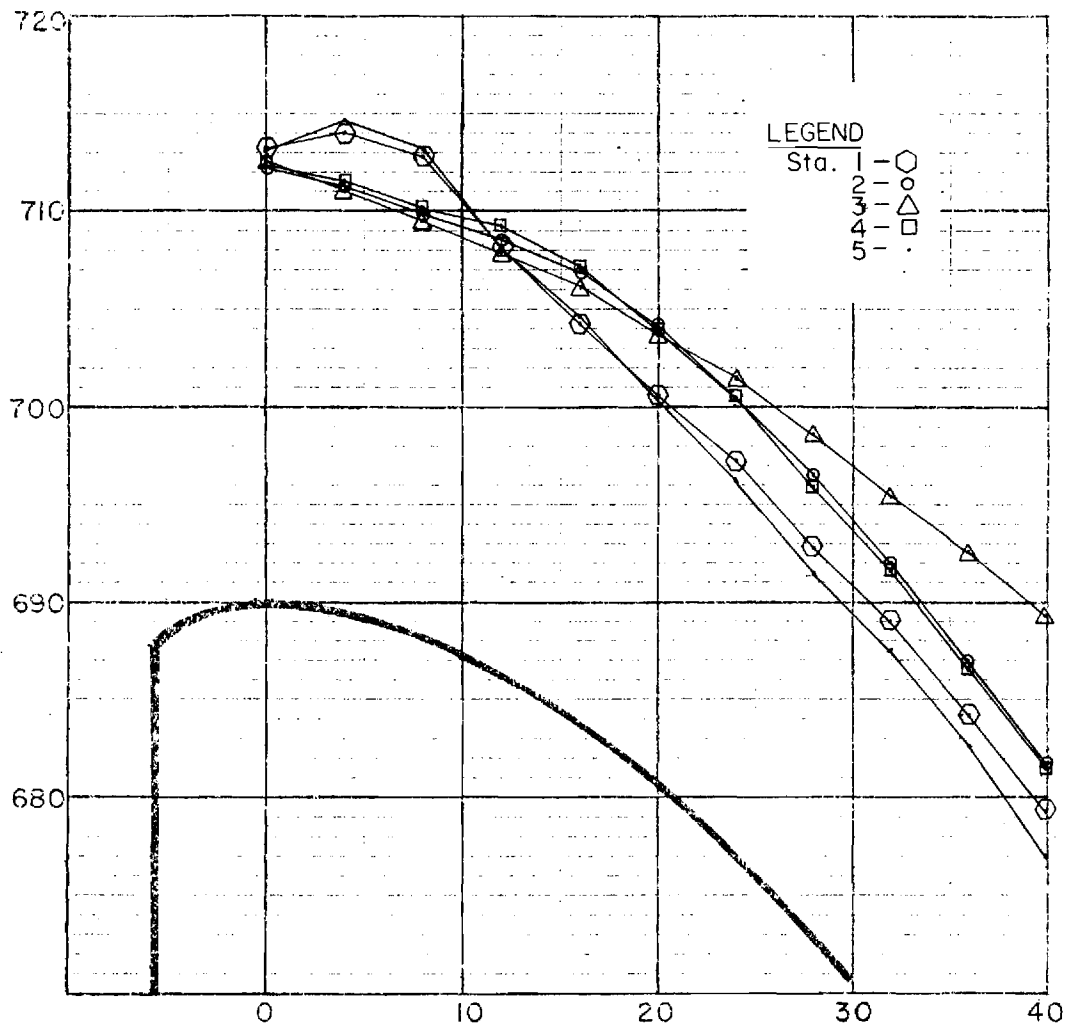

FIGURE 17.
 ROCKY MOUNTAIN PROJECT
 MAIN SPILLWAY MODEL STUDY
 1:40 SCALE MODEL

MODEL I, WATER SURFACE PROFILE

BAY NO. 2
 Q = 60,000 c.f.s.
 Res. El. = 717.5'

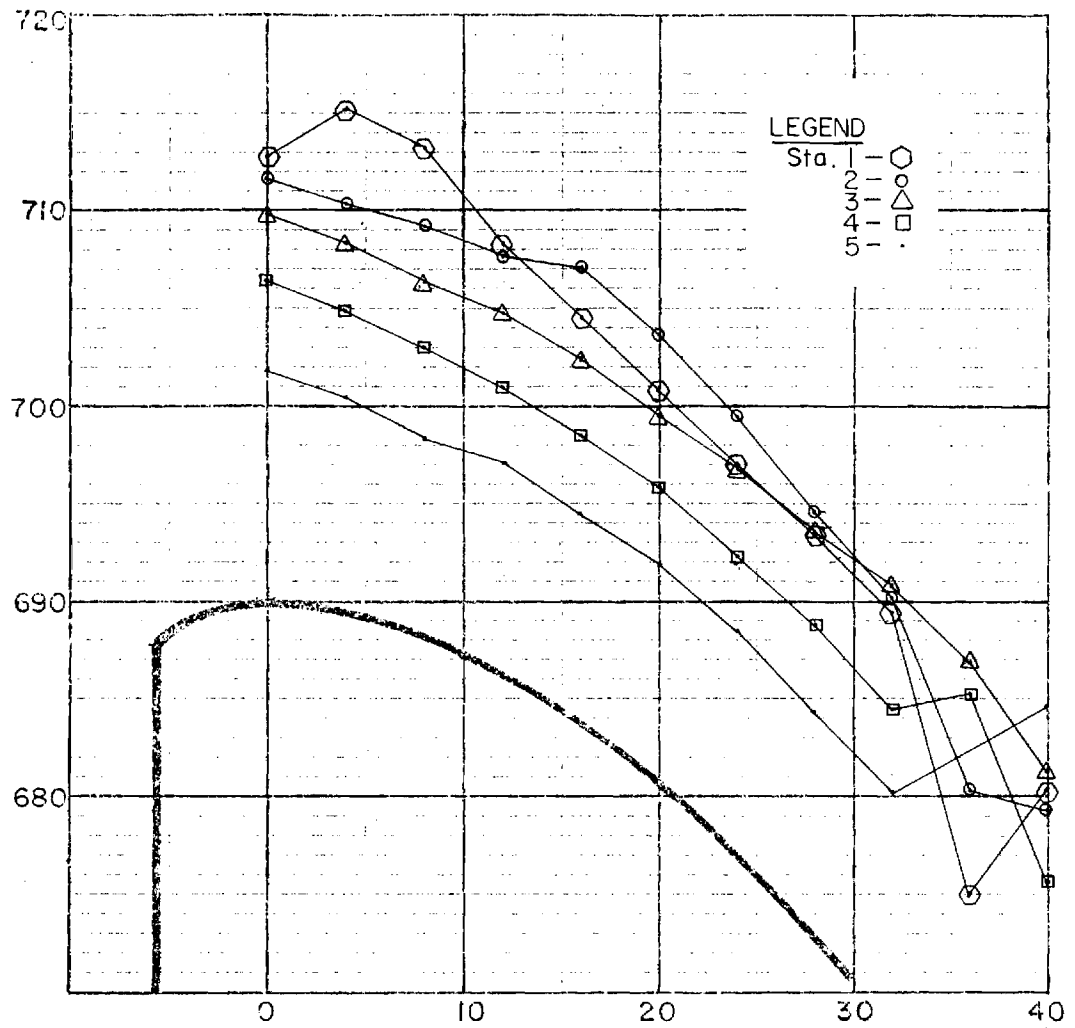

FIGURE 18.
 ROCKY MOUNTAIN PROJECT
 MAIN SPILLWAY MODEL STUDY
 1:40 SCALE MODEL

MODEL I, WATER SURFACE PROFILE

BAY NO. 3
 Q = 60,000 cfs.
 Res. El. = 717.5'

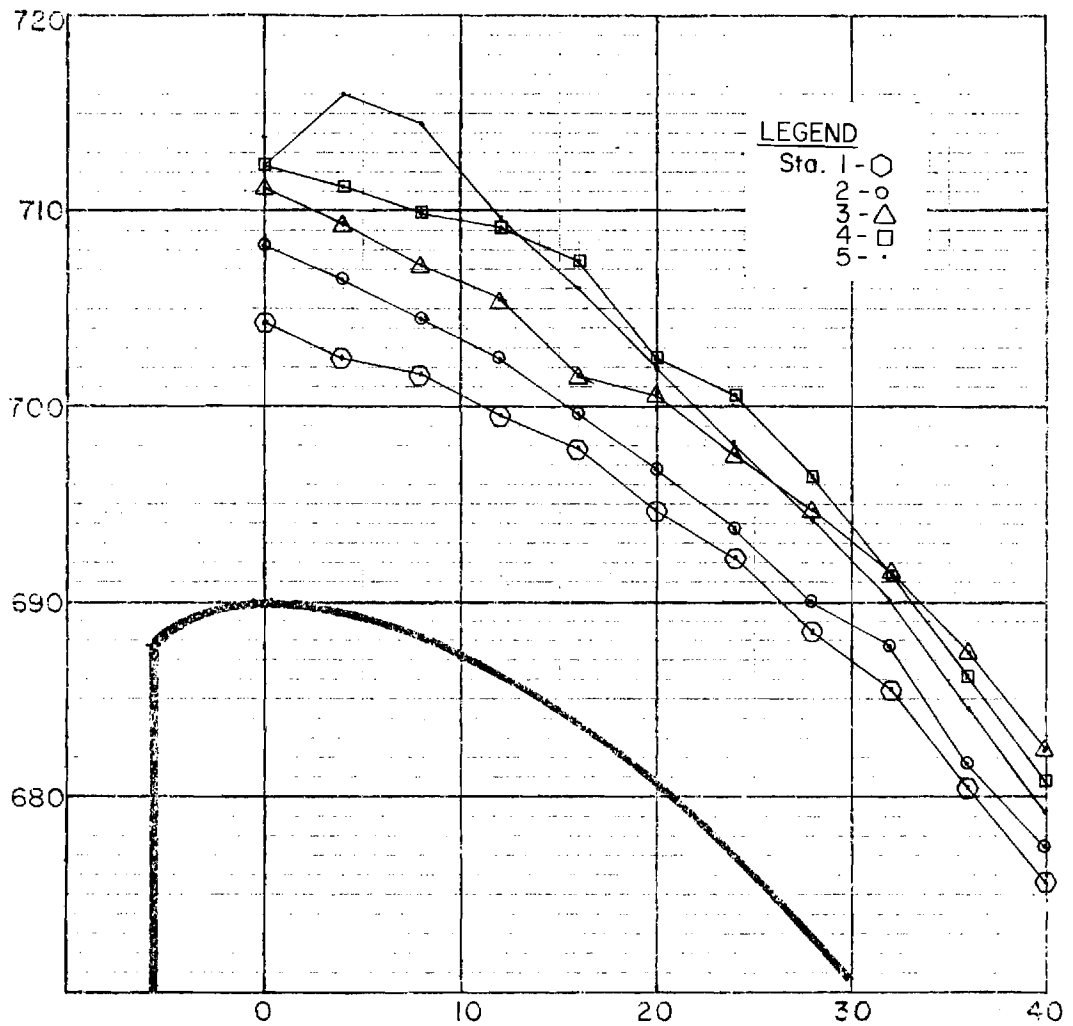

FIGURE 19.
 ROCKY MOUNTAIN PROJECT
 MAIN SPILLWAY MODEL STUDY
 1:40 SCALE MODEL

MODEL I, WATER SURFACE PROFILE

BAY NO. 1
 Q = 60,700 c.f.s.
 Res. El. = 717.6'

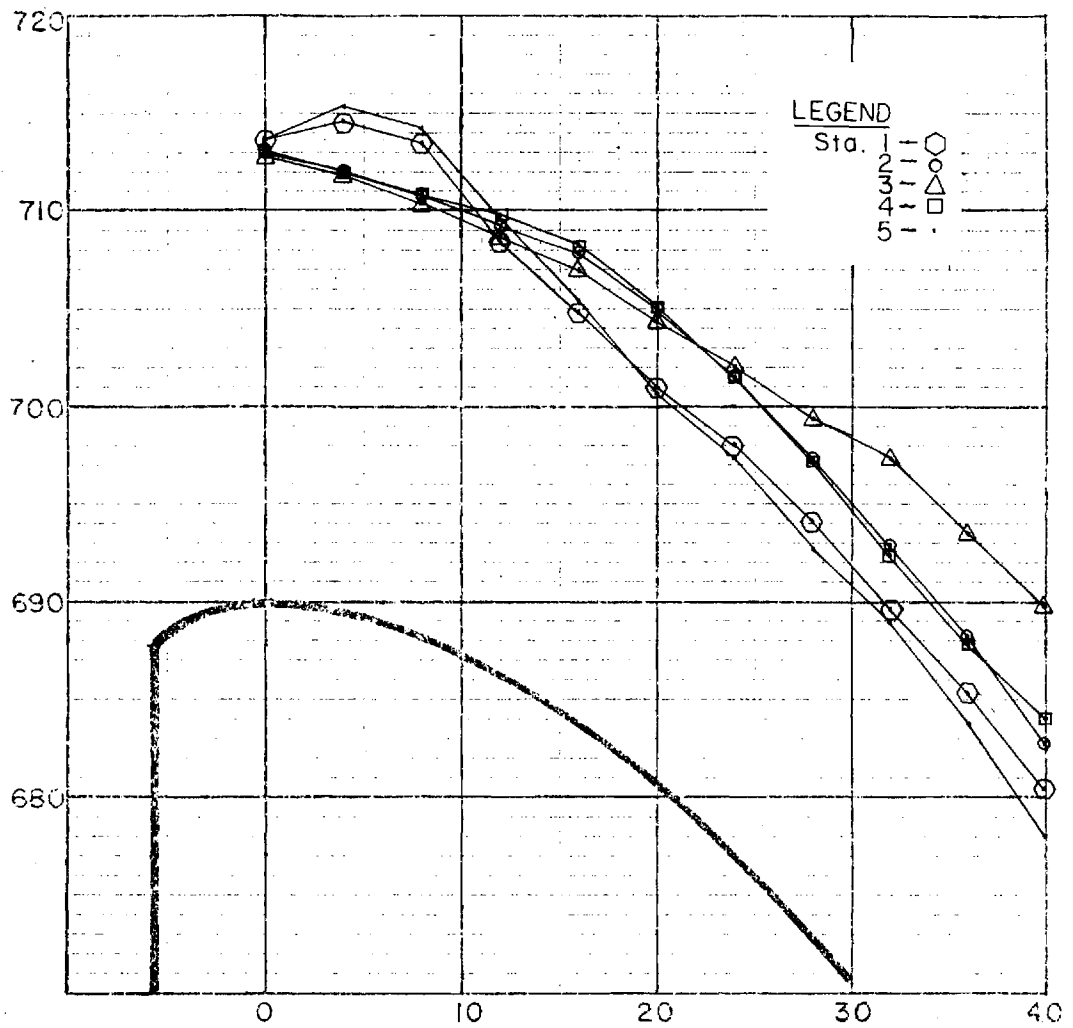

FIGURE 20.
 ROCKY MOUNTAIN PROJECT
 MAIN SPILLWAY MODEL STUDY
 1:40 SCALE MODEL

MODEL I, WATER SURFACE PROFILE

BAY NO. 2
 Q = 60,700 cfs.
 Res. El. = 717.6'

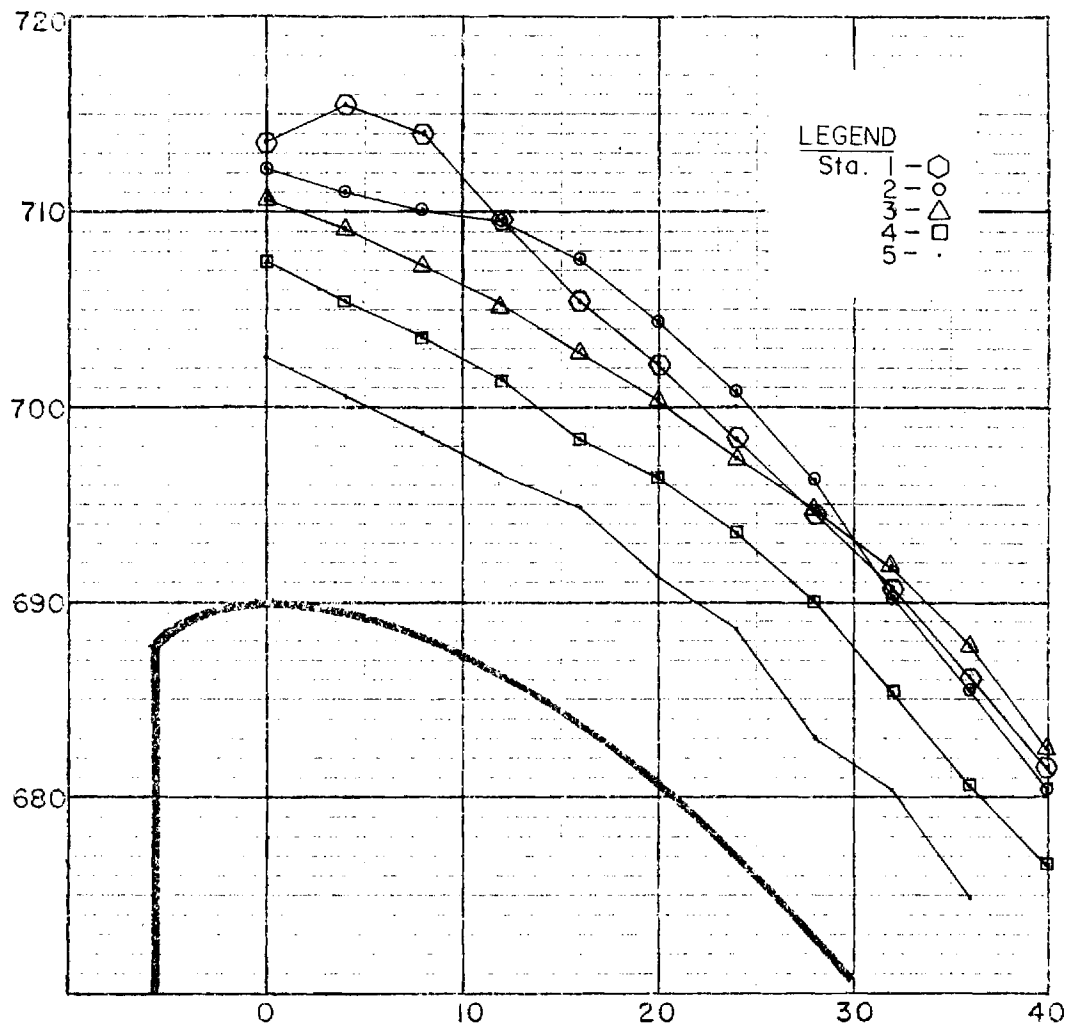

FIGURE 21 .
 ROCKY MOUNTAIN PROJECT
 MAIN SPILLWAY MODEL STUDY
 1:40 SCALE MODEL

MODEL I, WATER SURFACE PROFILE

BAY NO. 3
 Q = 60,700 c.f.s.
 Res. El. = 717.6'

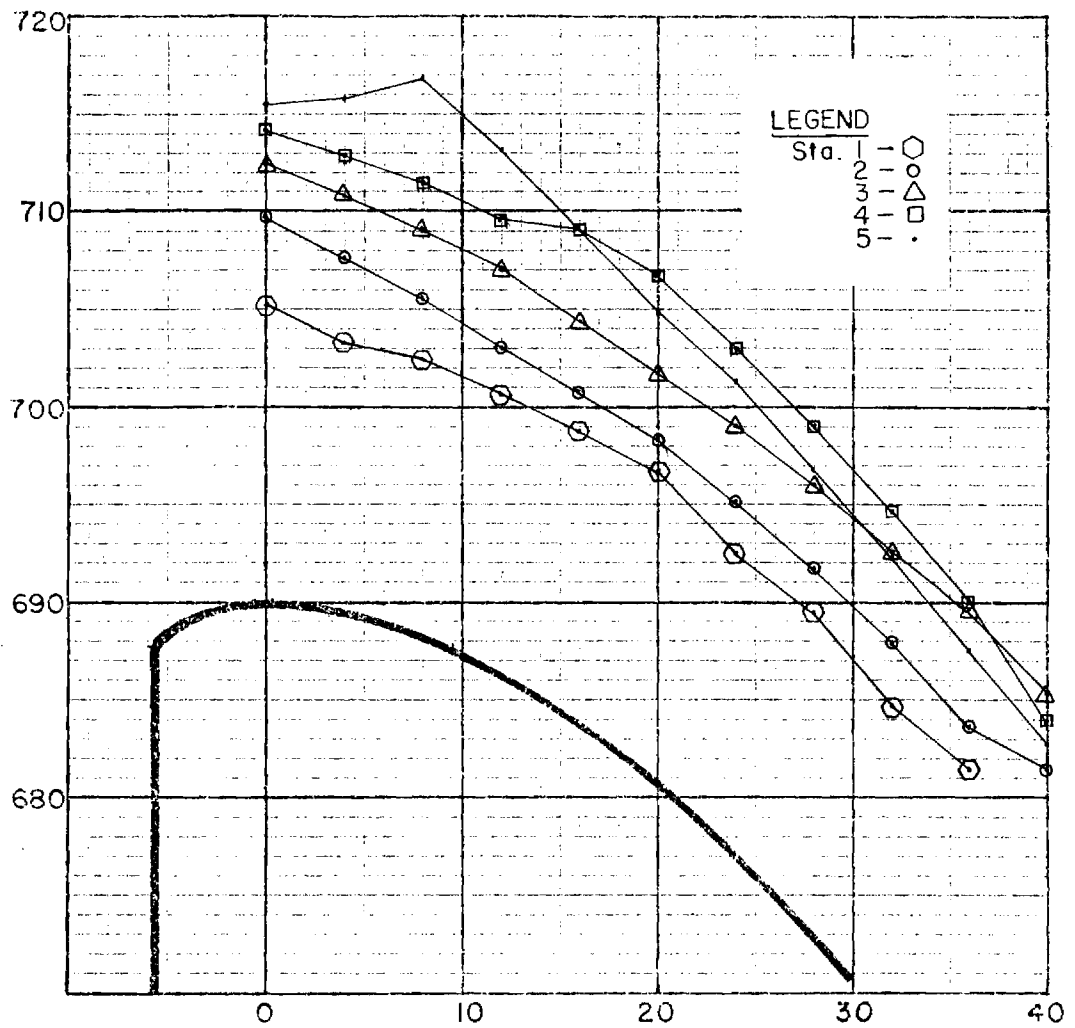

FIGURE 22.
 ROCKY MOUNTAIN PROJECT
 MAIN SPILLWAY MODEL STUDY
 1:40 SCALE MODEL

MODEL I, WATER SURFACE PROFILE

BAY NO. 1
 Q = 69,000 cfs
 Res. El. = 720.0'

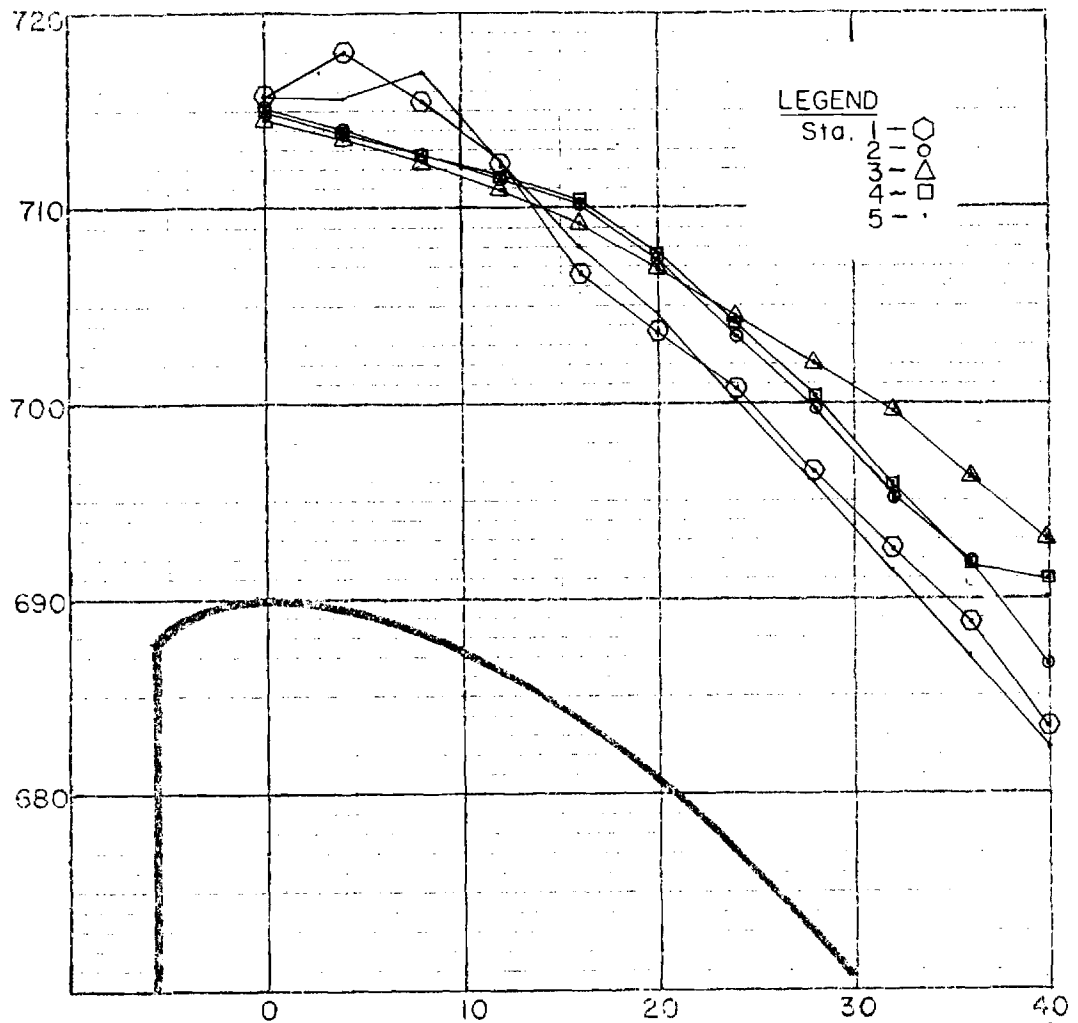

FIGURE 23.
 ROCKY MOUNTAIN PROJECT
 MAIN SPILLWAY MODEL STUDY
 1:40 SCALE MODEL

MODEL I, WATER SURFACE PROFILE

BAY NO. 2
 Q = 69,000 cfs
 Res. El. = 720.0'

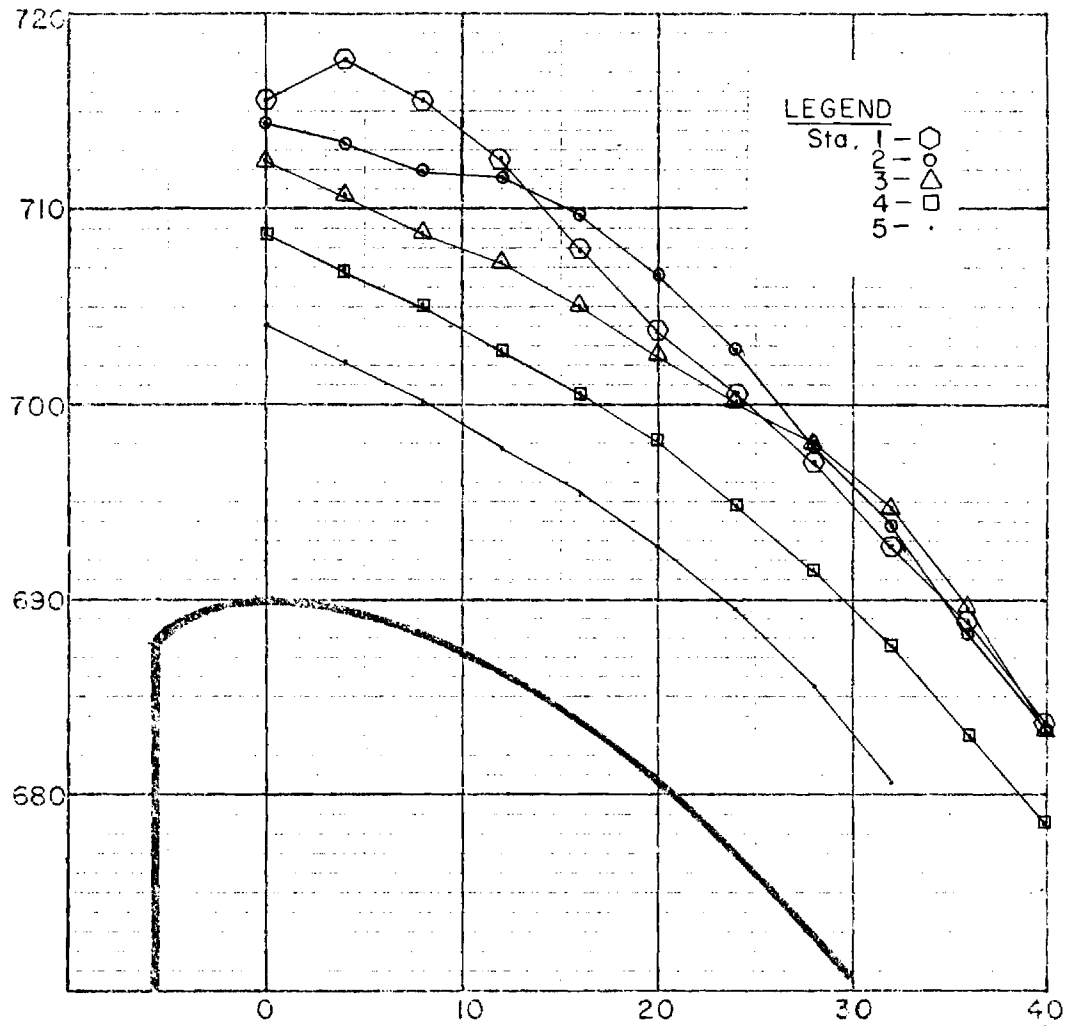

FIGURE 24.
 ROCKY MOUNTAIN PROJECT
 MAIN SPILLWAY MODEL STUDY
 1:40 SCALE MODEL

MODEL I, WATER SURFACE PROFILE

BAY NO. 3
 Q = 69,000 cfs
 Res. El. = 720.0'

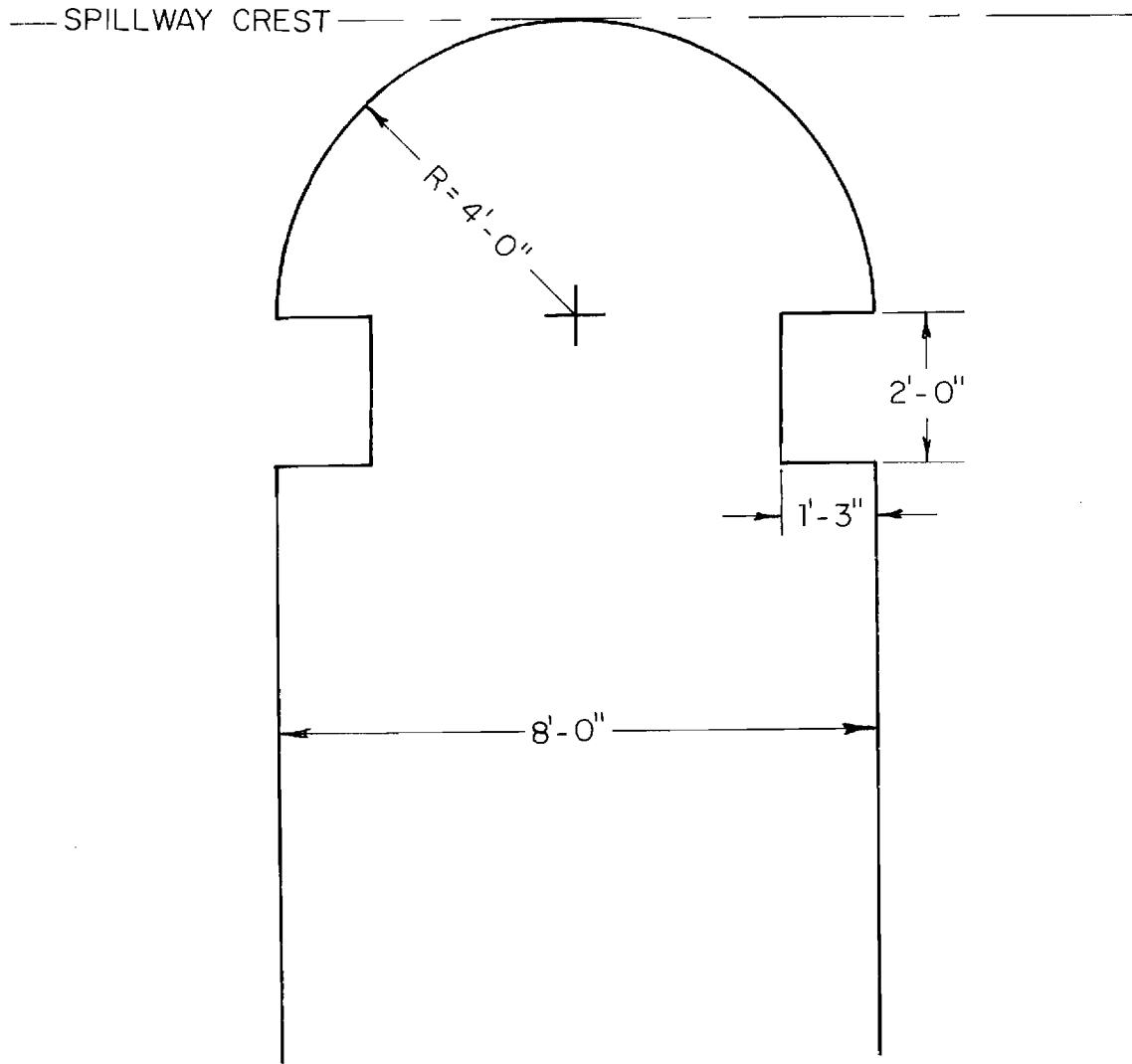

FIGURE 25.
ROCKY MOUNTAIN PROJECT
MAIN SPILLWAY MODEL STUDY
1:40 SCALE MODEL

MODEL II, DETAIL OF INTERIOR PIER

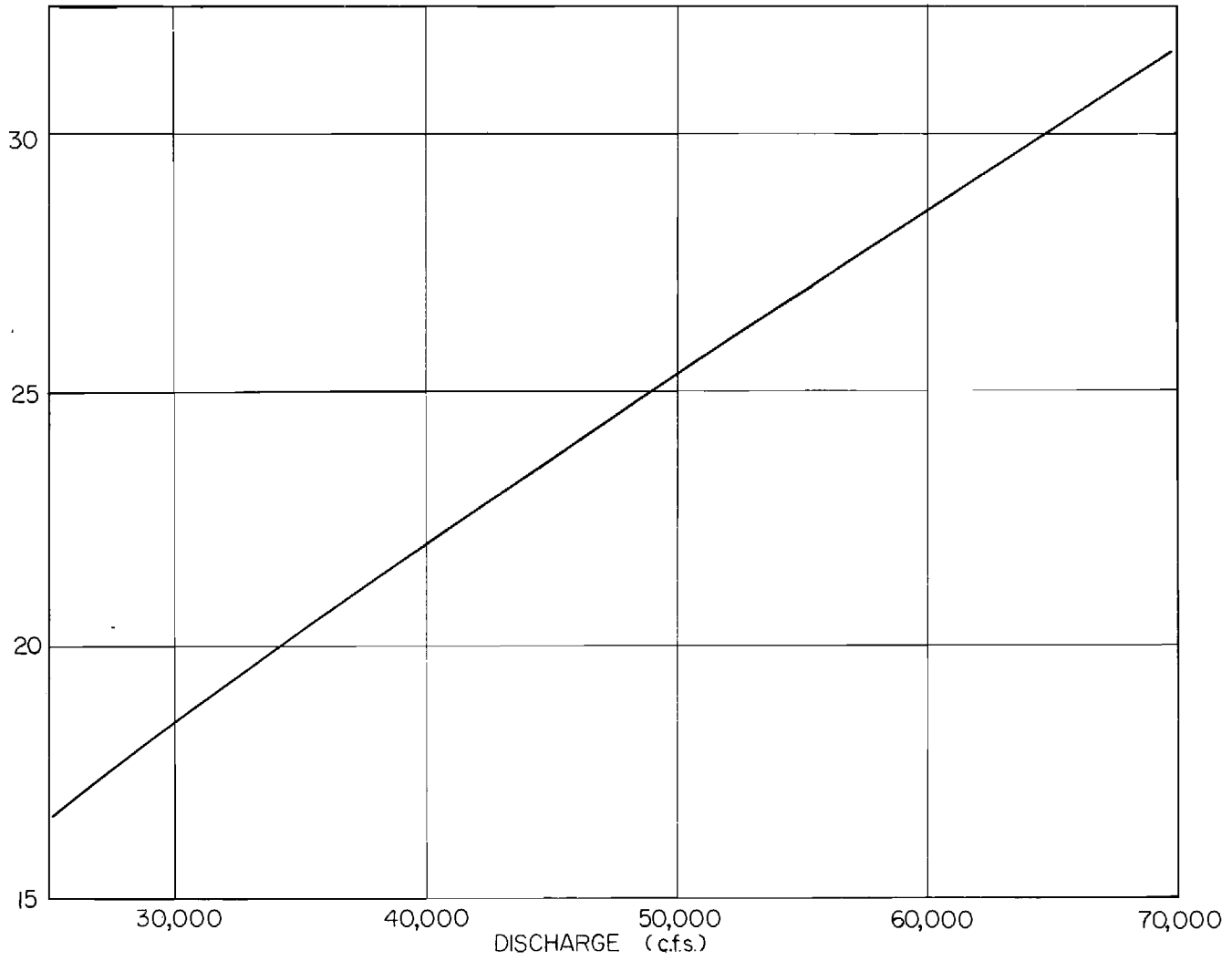

FIGURE 26.
ROCKY MOUNTAIN PROJECT
MAIN SPILLWAY MODEL STUDY
1:40 SCALE MODEL

MODEL II, SPILLWAY RATING CURVE

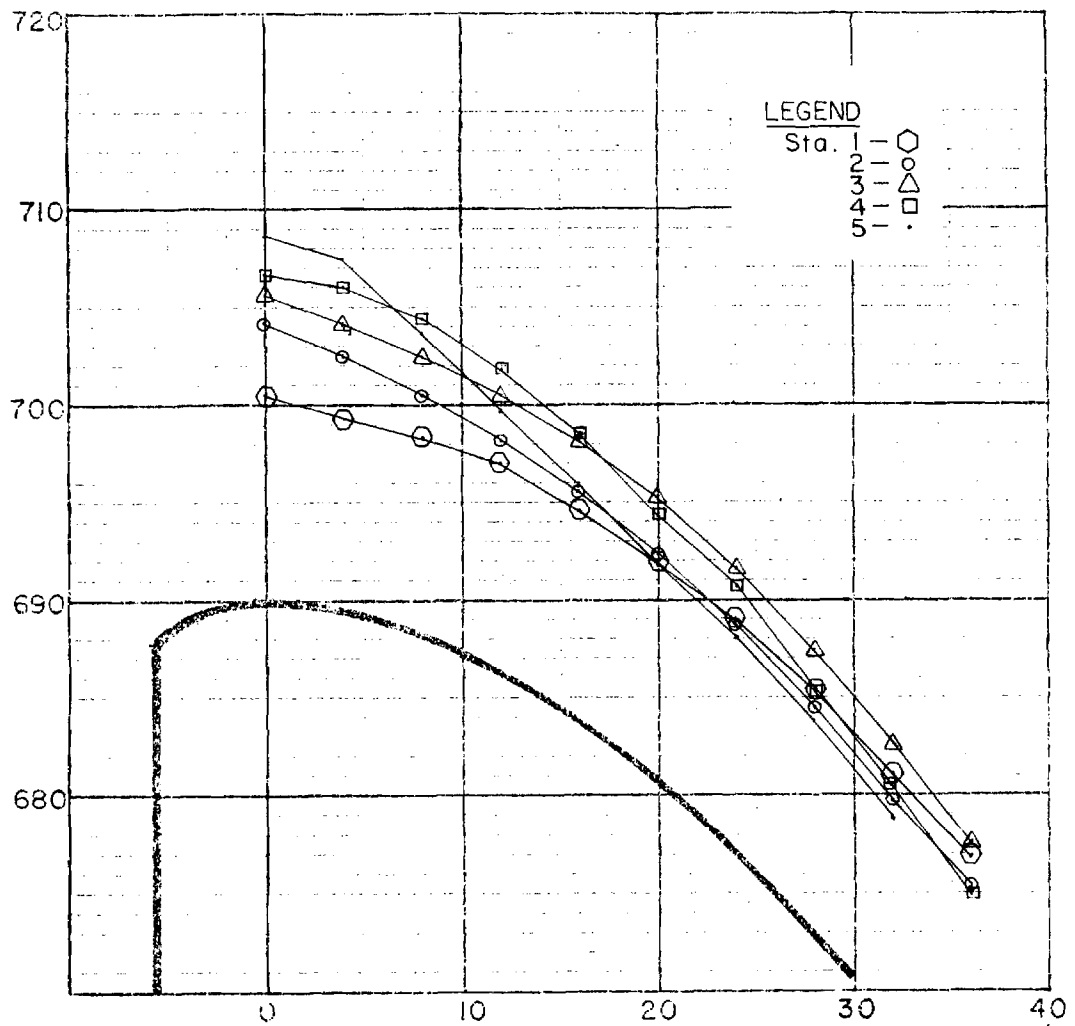

FIGURE 27.
 ROCKY MOUNTAIN PROJECT
 MAIN SPILLWAY MODEL STUDY
 1:40 SCALE MODEL

MODEL II, WATER SURFACE PROFILE

BAY NO. I
 Q = 36,370 c.f.s.
 Res. El. = 710.8'

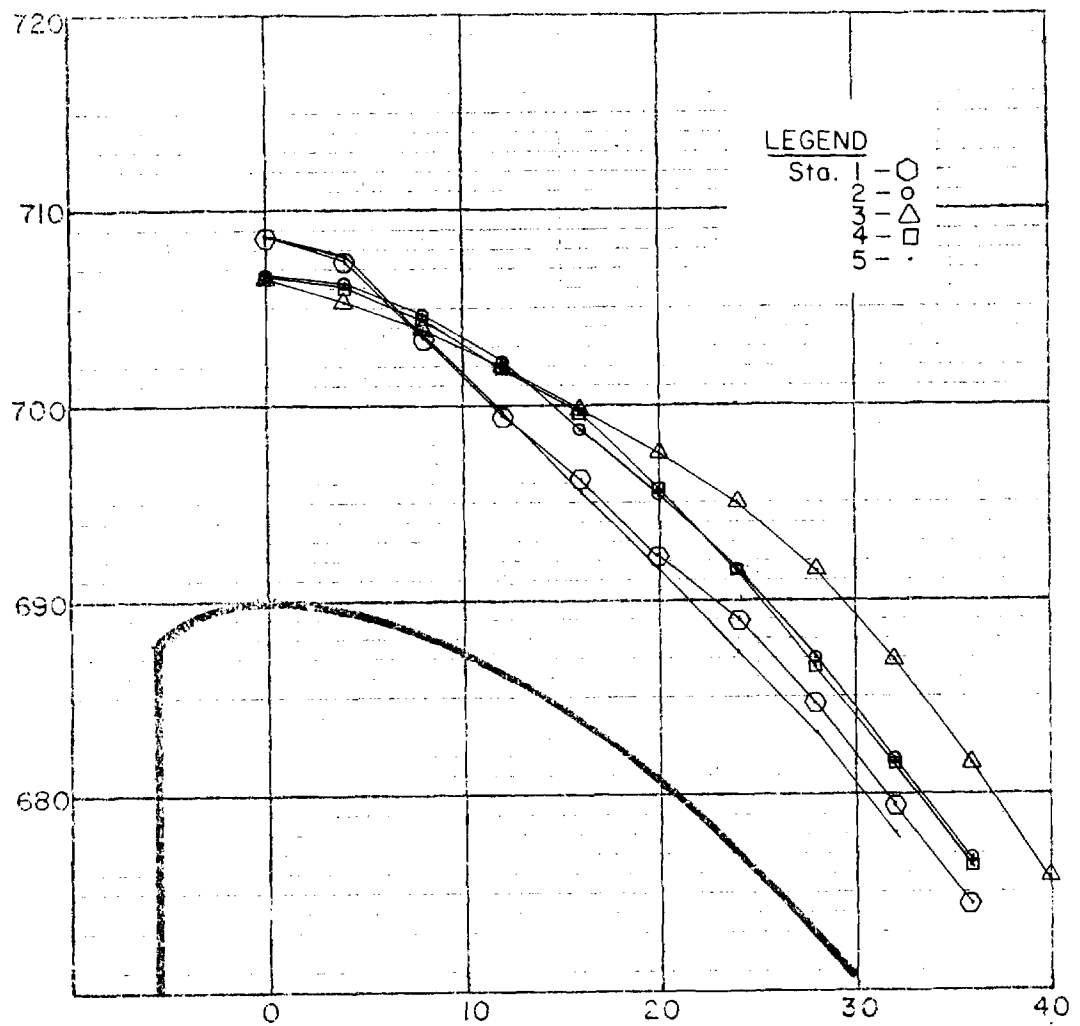

FIGURE 28.
 ROCKY MOUNTAIN PROJECT
 MAIN SPILLWAY MODEL STUDY
 1:40 SCALE MODEL

MODEL II, WATER SURFACE PROFILE

BAY NO. 2
 $Q = 36,370$ c.f.s.
 Res. El. = $710.8'$

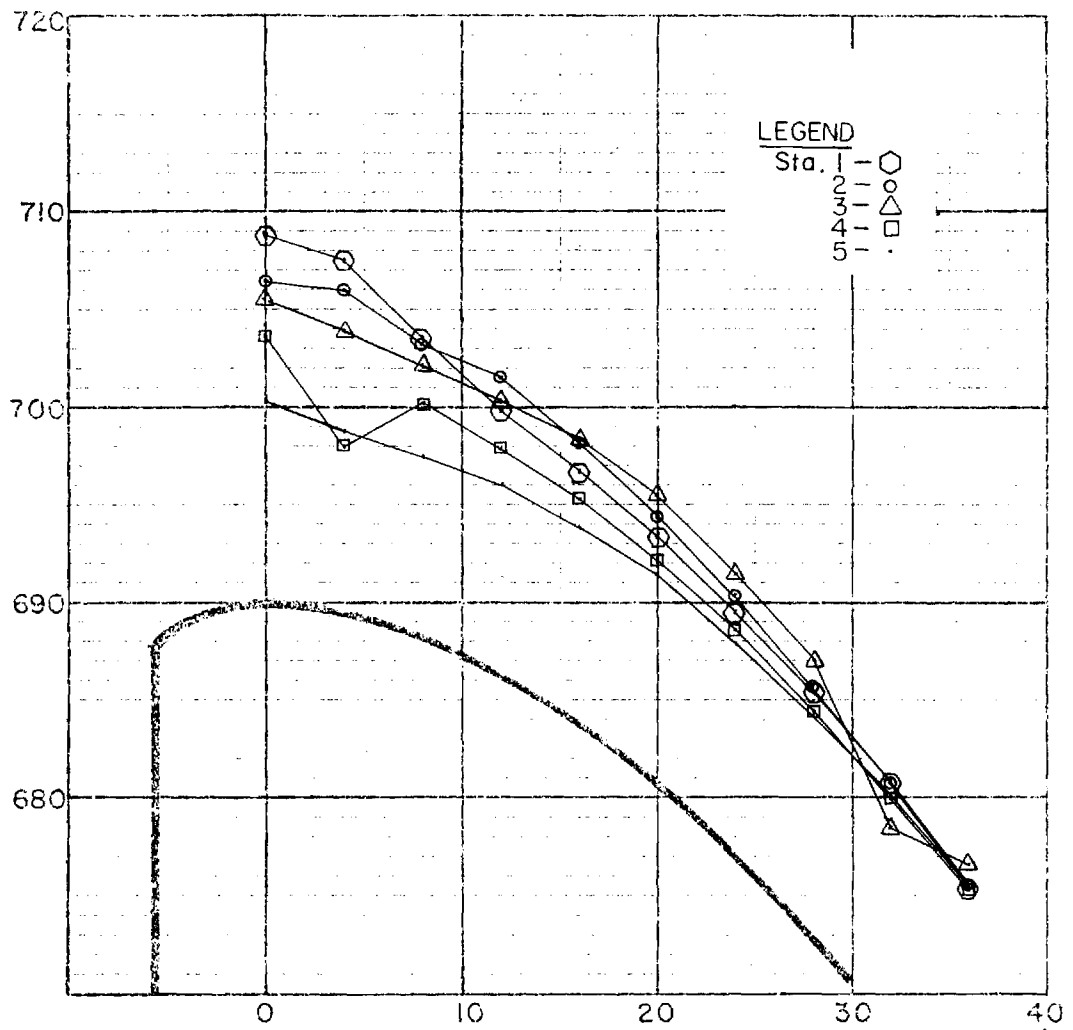

FIGURE 29.
 ROCKY MOUNTAIN PROJECT
 MAIN SPILLWAY MODEL STUDY
 1:40 SCALE MODEL

MODEL II, WATER SURFACE PROFILE

BAY NO. 3
 Q = 36,370 c.f.s.
 Res. El. = 710.8'

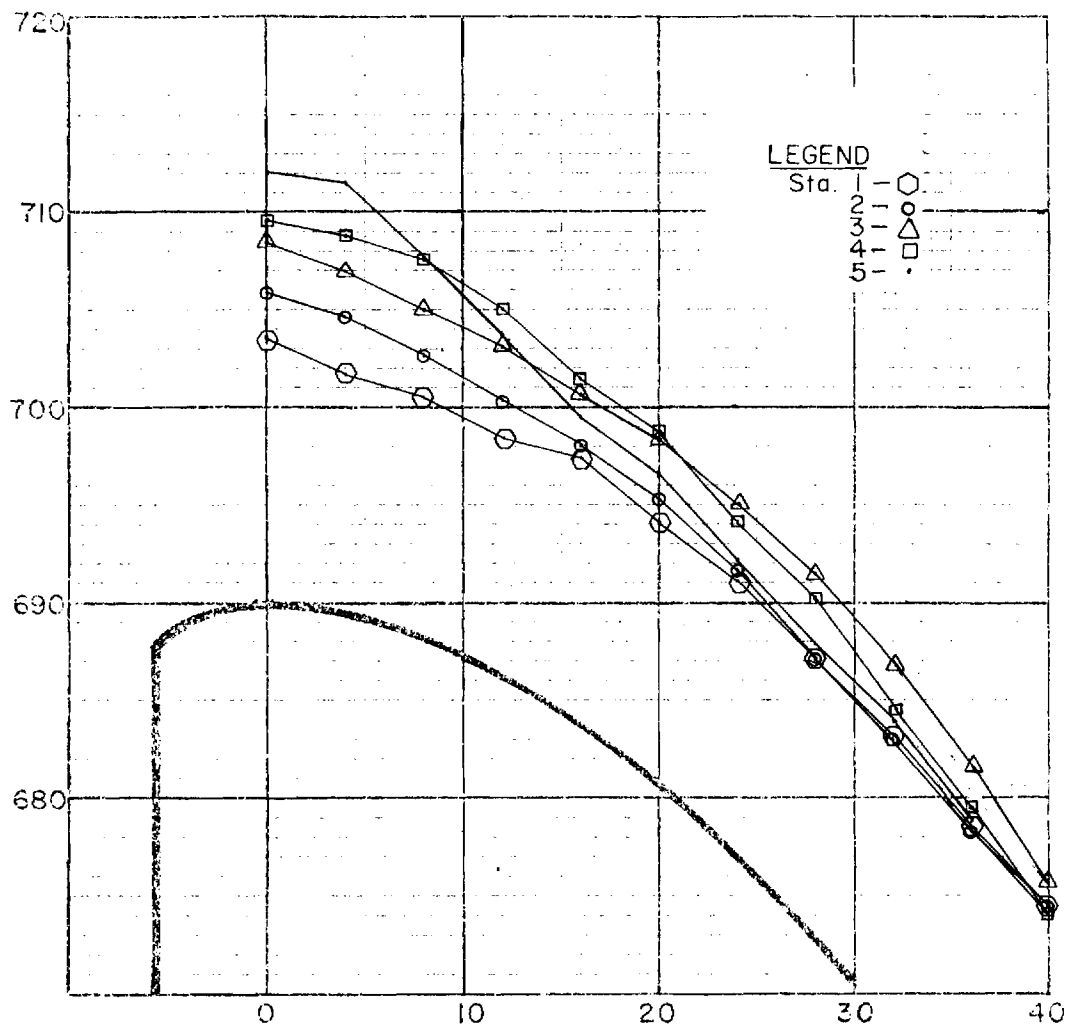

FIGURE 30.
ROCKY MOUNTAIN PROJECT
MAIN SPILLWAY MODEL STUDY
1:40 SCALE MODEL

MODEL II, WATER SURFACE PROFILE

BAY NO. I
Q = 46,950 c.f.s.
Res. El. = 714.3'

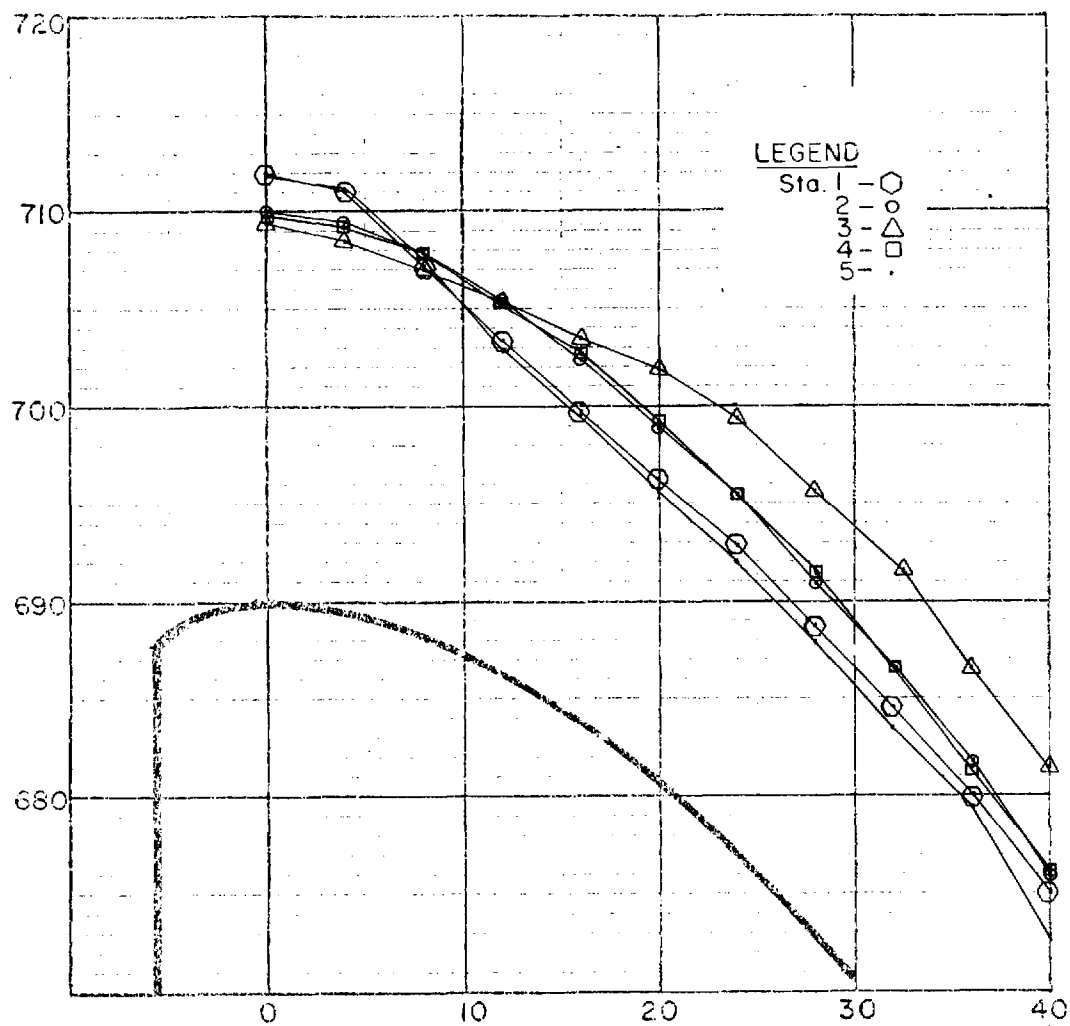

FIGURE 31.
 ROCKY MOUNTAIN PROJECT
 MAIN SPILLWAY MODEL STUDY
 1:40 SCALE MODEL

MODEL II, WATER SURFACE PROFILE

BAY NO. 2
 Q = 46,950 c.f.s.
 Res. El. = 714.3'

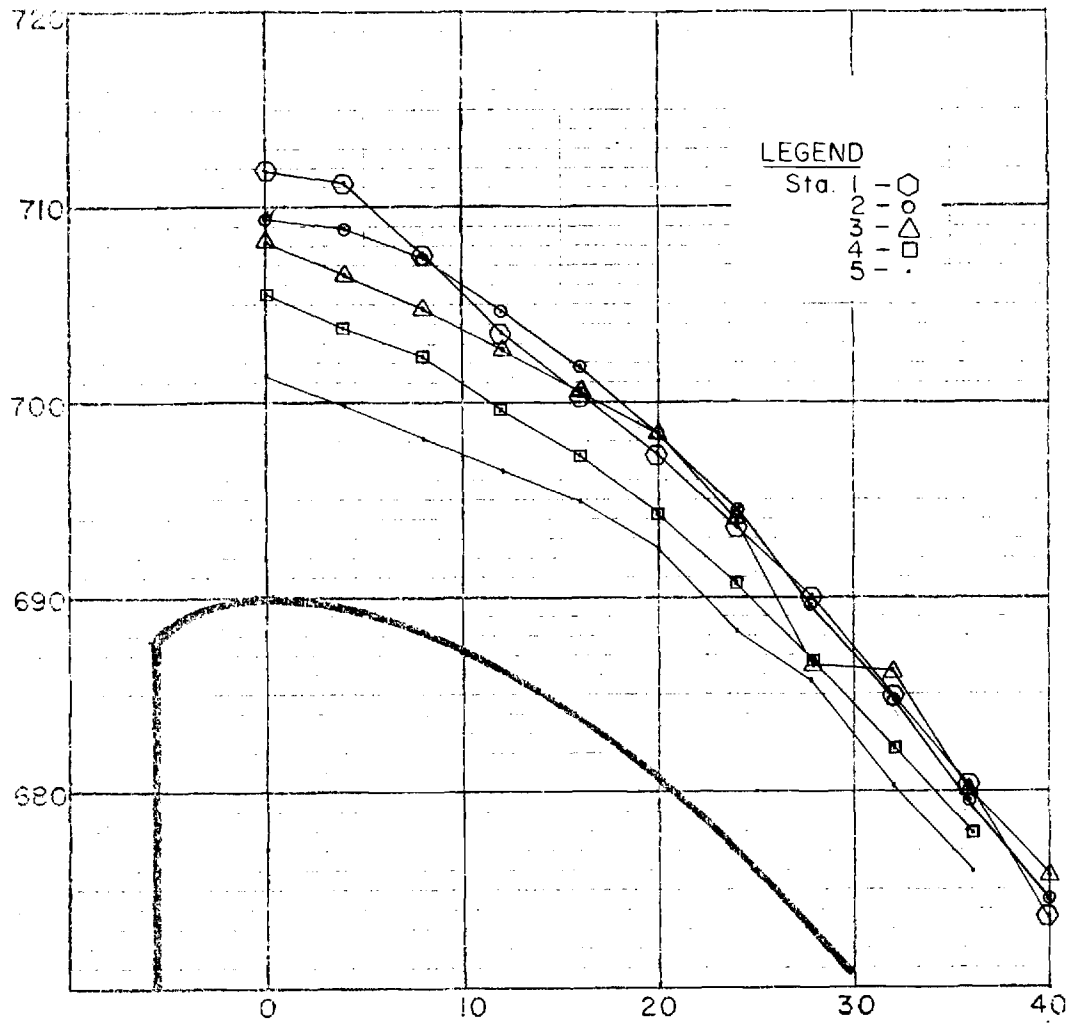

FIGURE 32.
 ROCKY MOUNTAIN PROJECT
 MAIN SPILLWAY MODEL STUDY
 1:40 SCALE MODEL

MODEL II, WATER SURFACE PROFILE

BAY NO. 3
 Q = 46,950 cfs.
 Res. El. = 714.3'

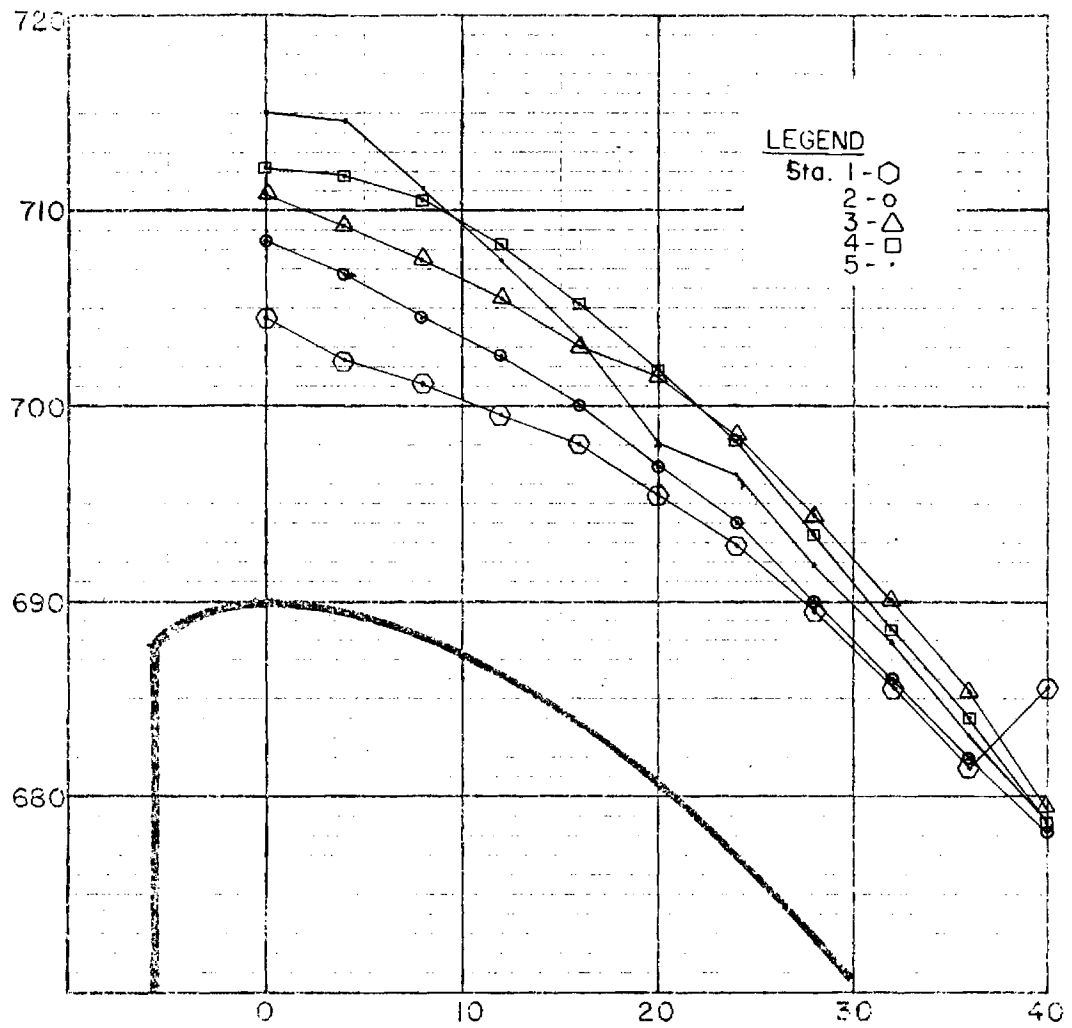

FIGURE 33.
 ROCKY MOUNTAIN PROJECT
 MAIN SPILLWAY MODEL STUDY
 1:40 SCALE MODEL

MODEL II, WATER SURFACE PROFILE

BAY NO. 1
 Q = 57,100 cfs
 Res. El. = 717.6'

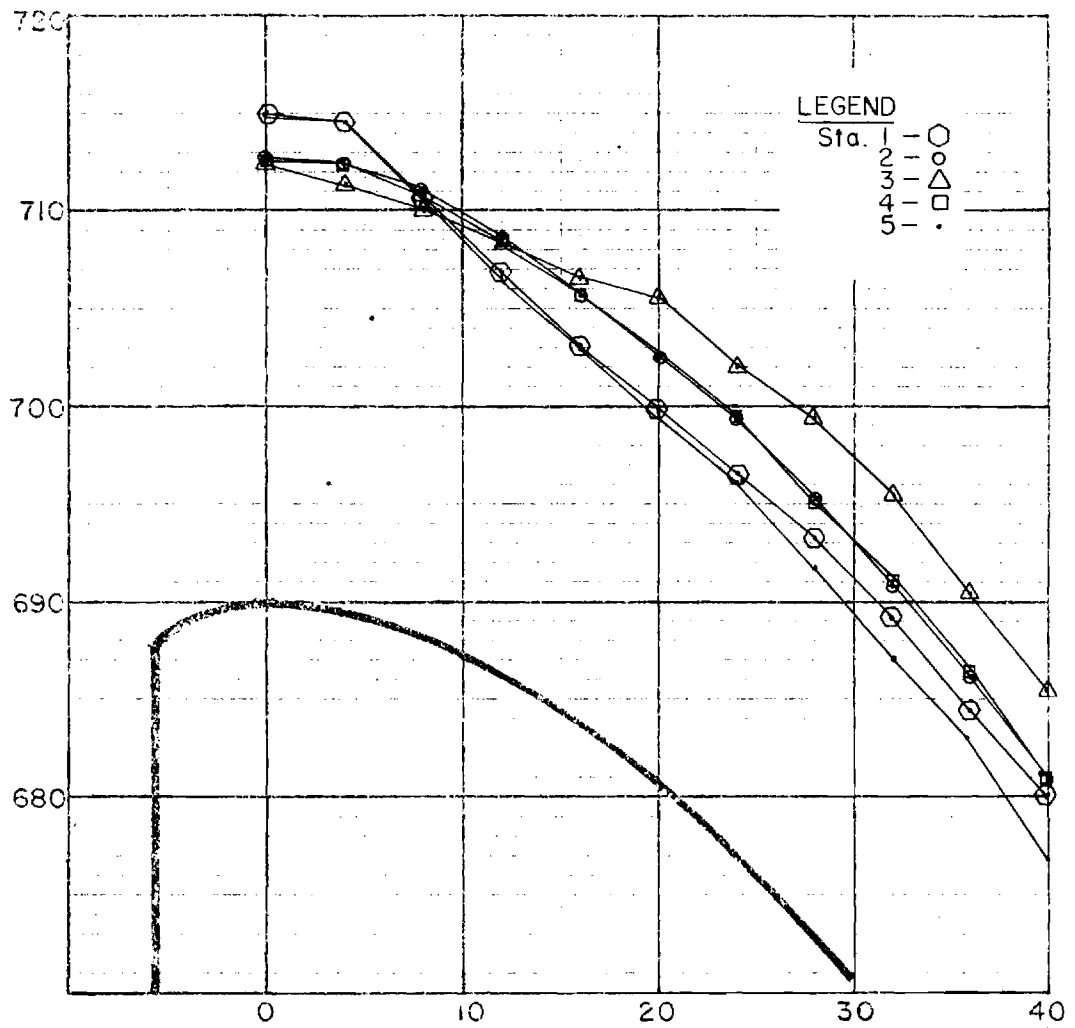

FIGURE 34.
 ROCKY MOUNTAIN PROJECT
 MAIN SPILLWAY MODEL STUDY
 1:40 SCALE MODEL

MODEL II, WATER SURFACE PROFILE

BAY NO. 2
 Q = 57,100 cfs
 Res. El. = 717.6'

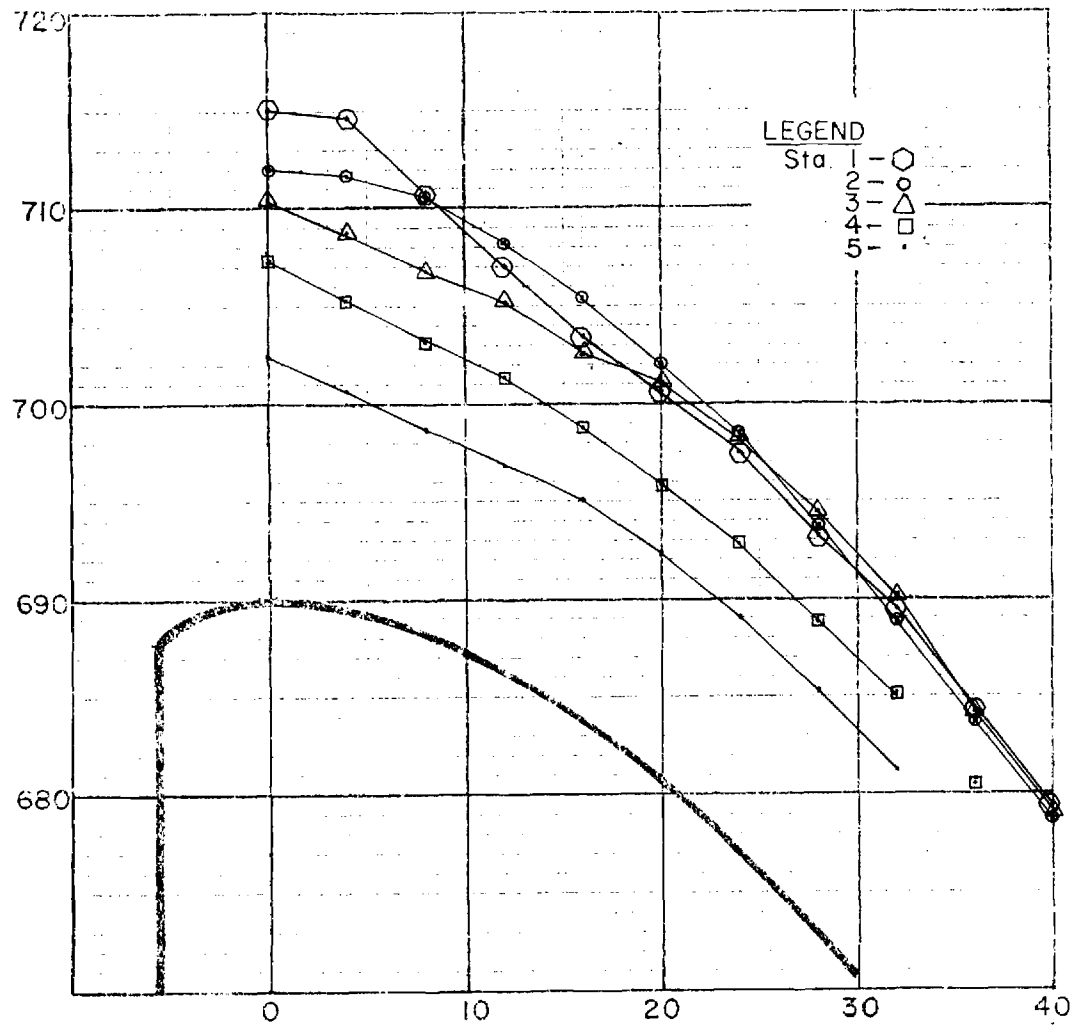

FIGURE 35.
 ROCKY MOUNTAIN PROJECT
 MAIN SPILLWAY MODEL STUDY
 1:40 SCALE MODEL

MODEL II, WATER SURFACE PROFILE

BAY NO. 3
 Q = 57,100 cfs
 Res. El. = 717.6'

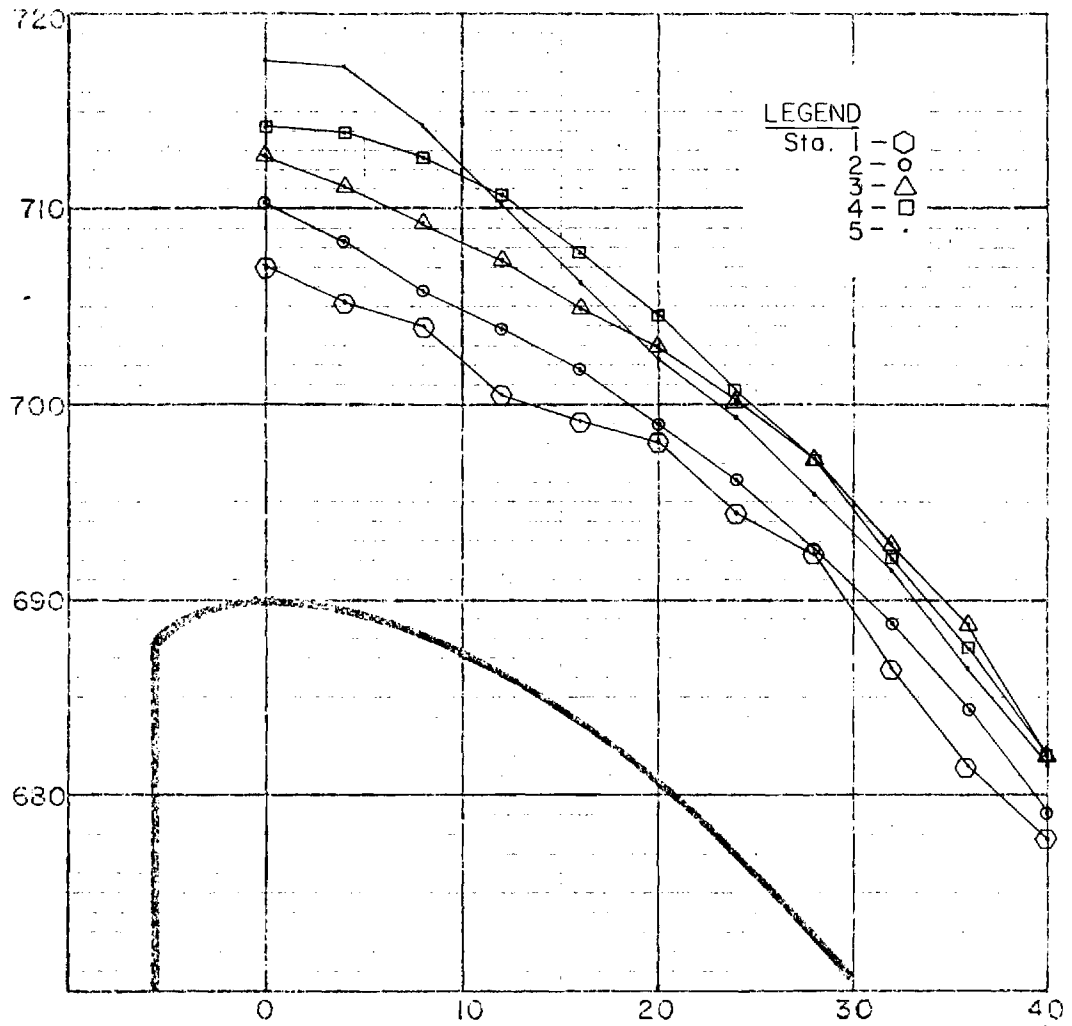

FIGURE 36.
 ROCKY MOUNTAIN PROJECT
 MAIN SPILLWAY MODEL STUDY
 1:40 SCALE MODEL

MODEL II, WATER SURFACE PROFILE

BAY NO. 1
 Q = 66,450 c.f.s.
 Res. El. = 720.4'

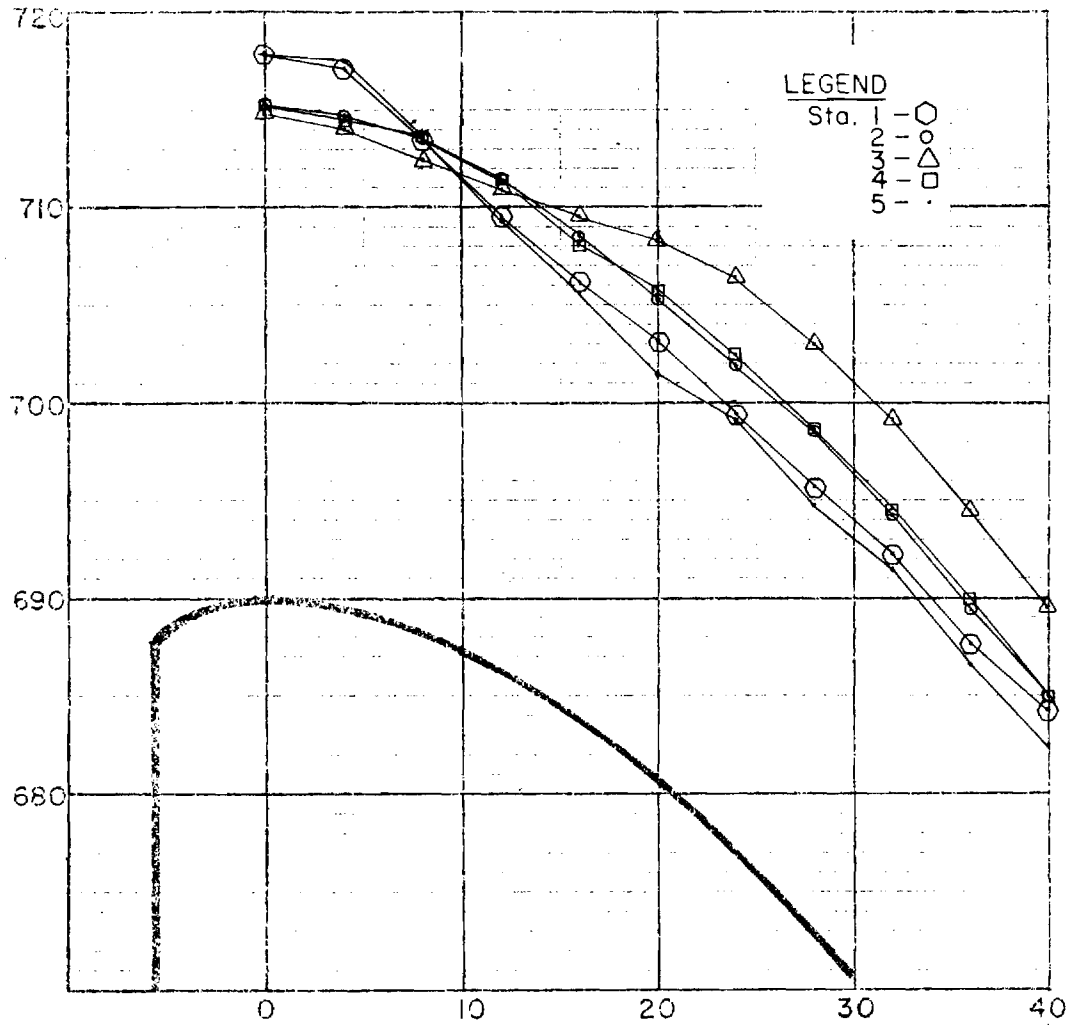

FIGURE 37.
 ROCKY MOUNTAIN PROJECT
 MAIN SPILLWAY MODEL STUDY
 1:40 SCALE MODEL

MODEL II, WATER SURFACE PROFILE

BAY NO. 2
 $Q = 66,450$ cfs.
 Res. El. = $720.4'$

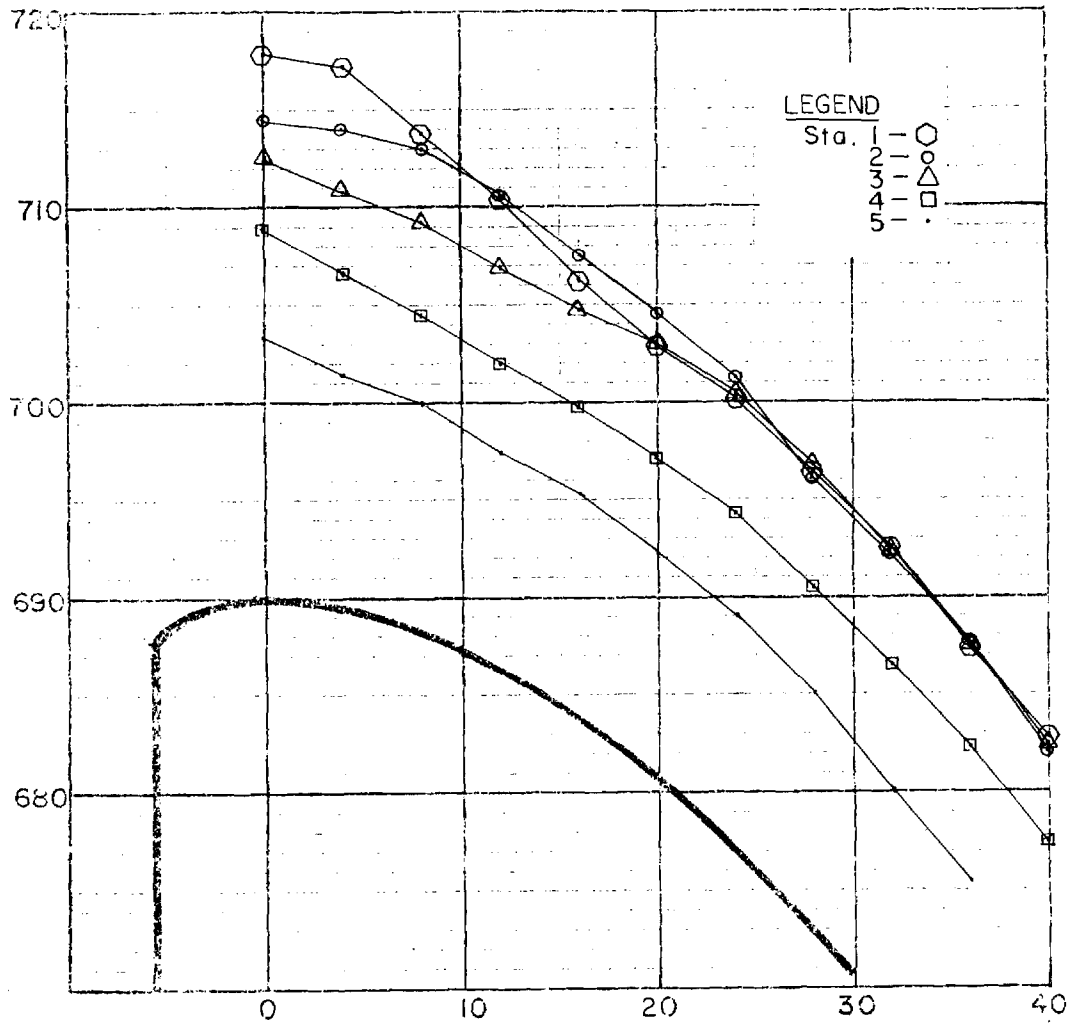

FIGURE 38.
 ROCKY MOUNTAIN PROJECT
 MAIN SPILLWAY MODEL STUDY
 1:40 SCALE MODEL

MODEL II, WATER SURFACE PROFILE

BAY NO. 3
 Q = 66,450 cfs.
 Res. El. = 720.4'

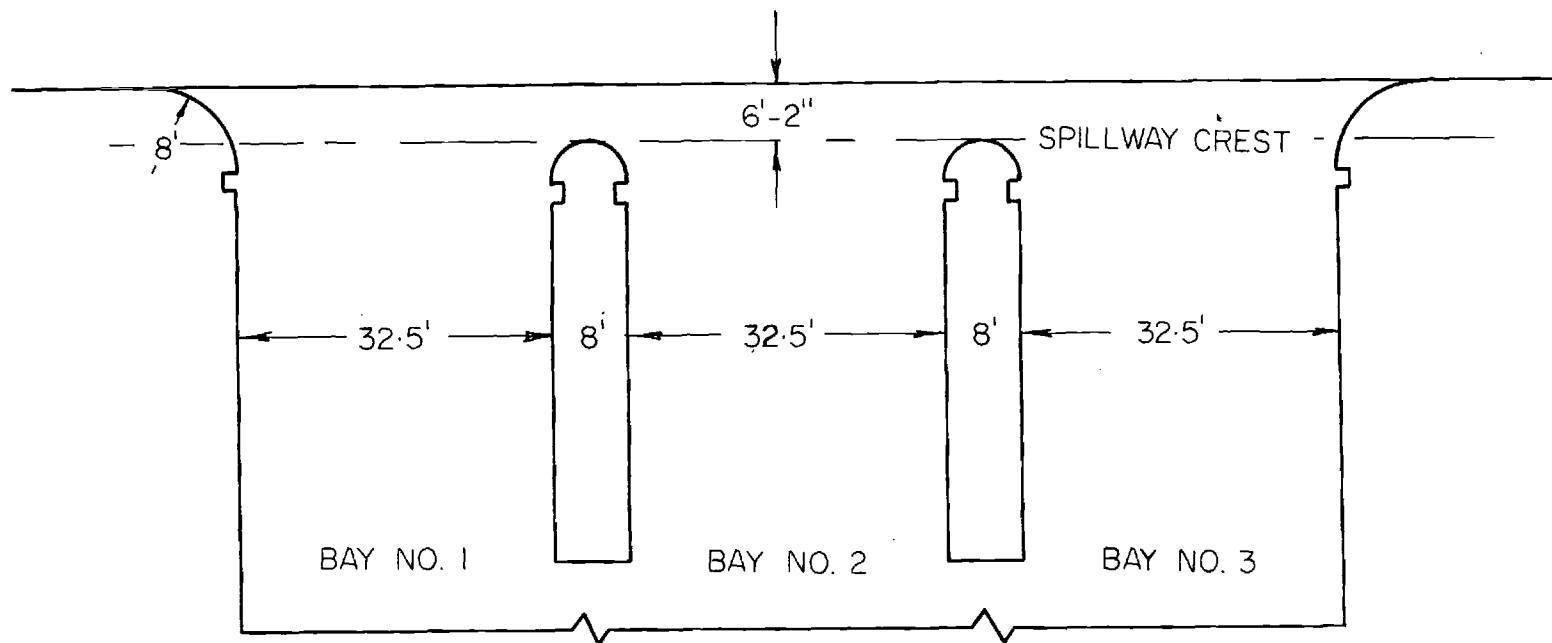

FIGURE 39.
ROCKY MOUNTAIN PROJECT
MAIN SPILLWAY MODEL STUDY
1:40 SCALE MODEL

MODEL III, PLAN VIEW

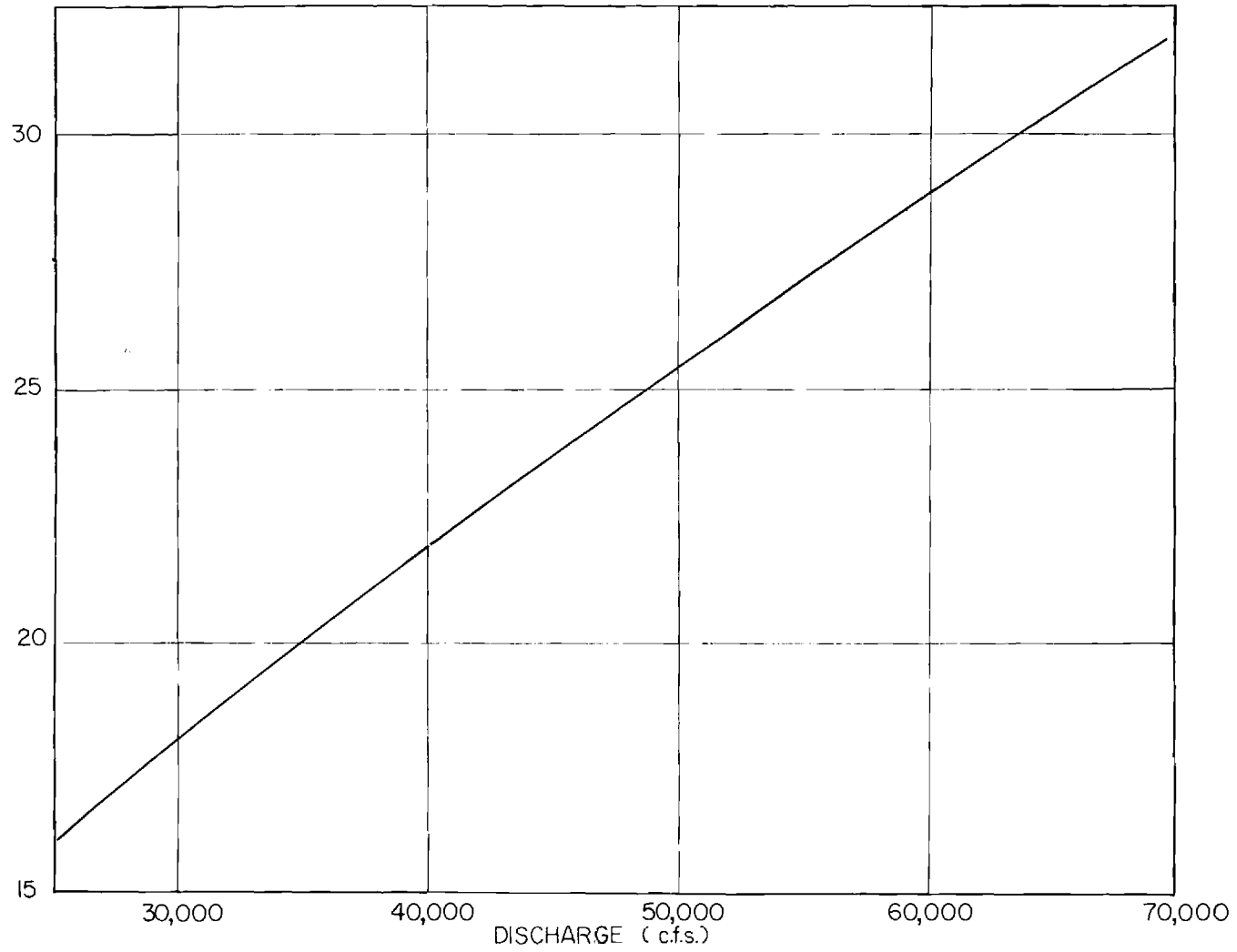

FIGURE 40.
ROCKY MOUNTAIN PROJECT
MAIN SPILLWAY MODEL STUDY
1:40 SCALE MODEL

MODEL III, SPILLWAY RATING CURVE

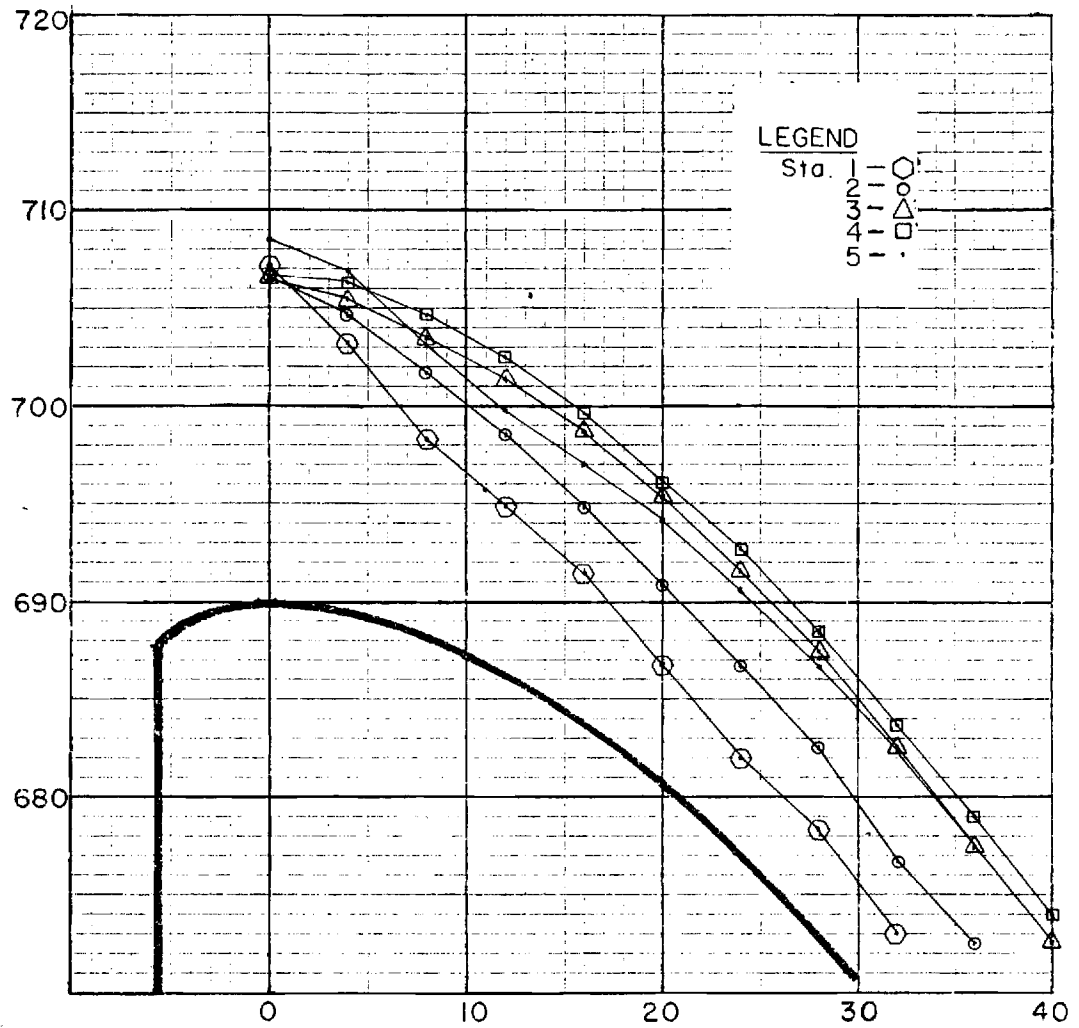

FIGURE 4I.
 ROCKY MOUNTAIN PROJECT
 MAIN SPILLWAY MODEL STUDY
 1:40 SCALE MODEL

MODEL III, WATER SURFACE PROFILE

BAY NO. I
 Q = 37,210 cfs.
 Res. El. = 710.0'

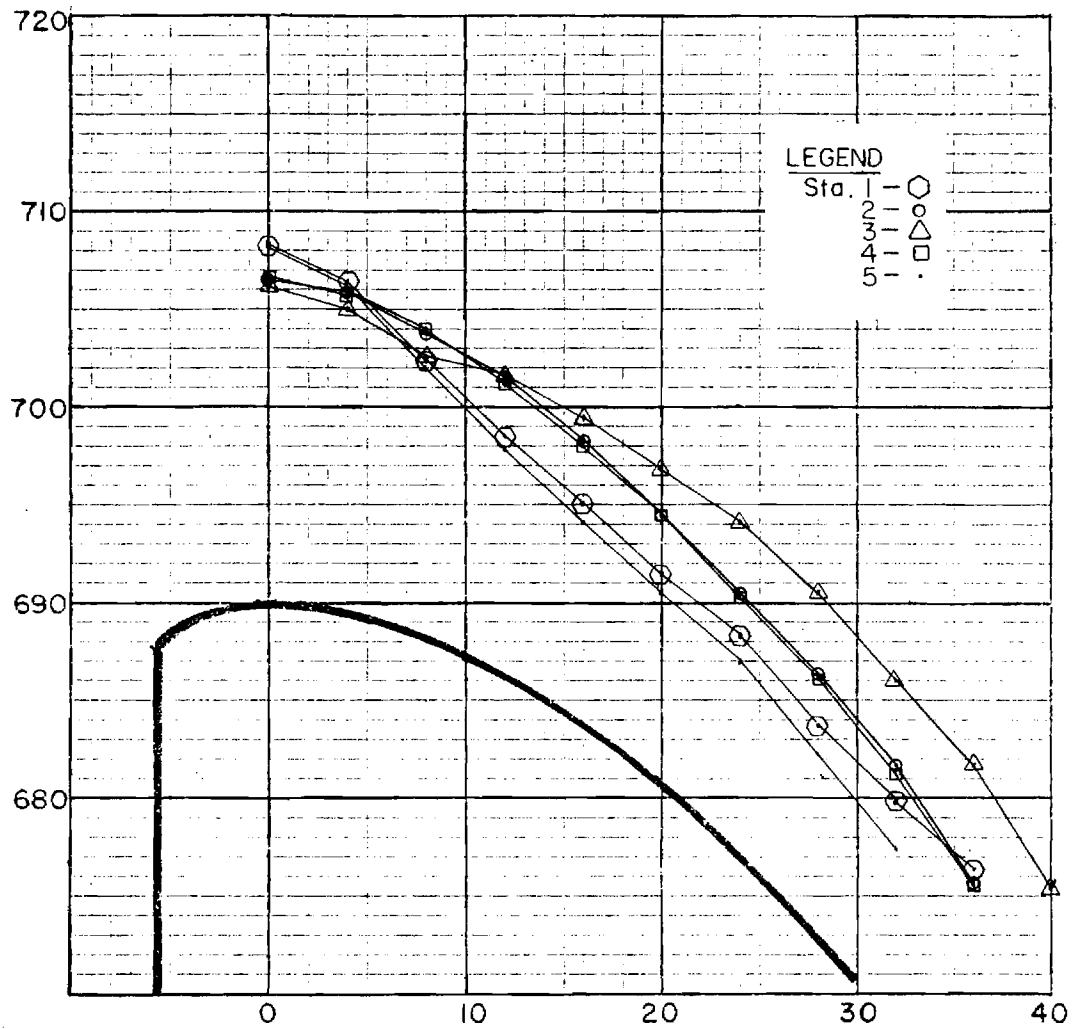

FIGURE 42.
 ROCKY MOUNTAIN PROFILE
 MAIN SPILLWAY MODEL STUDY
 1:40 SCALE MODEL

MODEL III, WATER SURFACE PROFILE

BAY NO. 2
 Q = 37,210 c.f.s.
 Res. El. = 710.0'

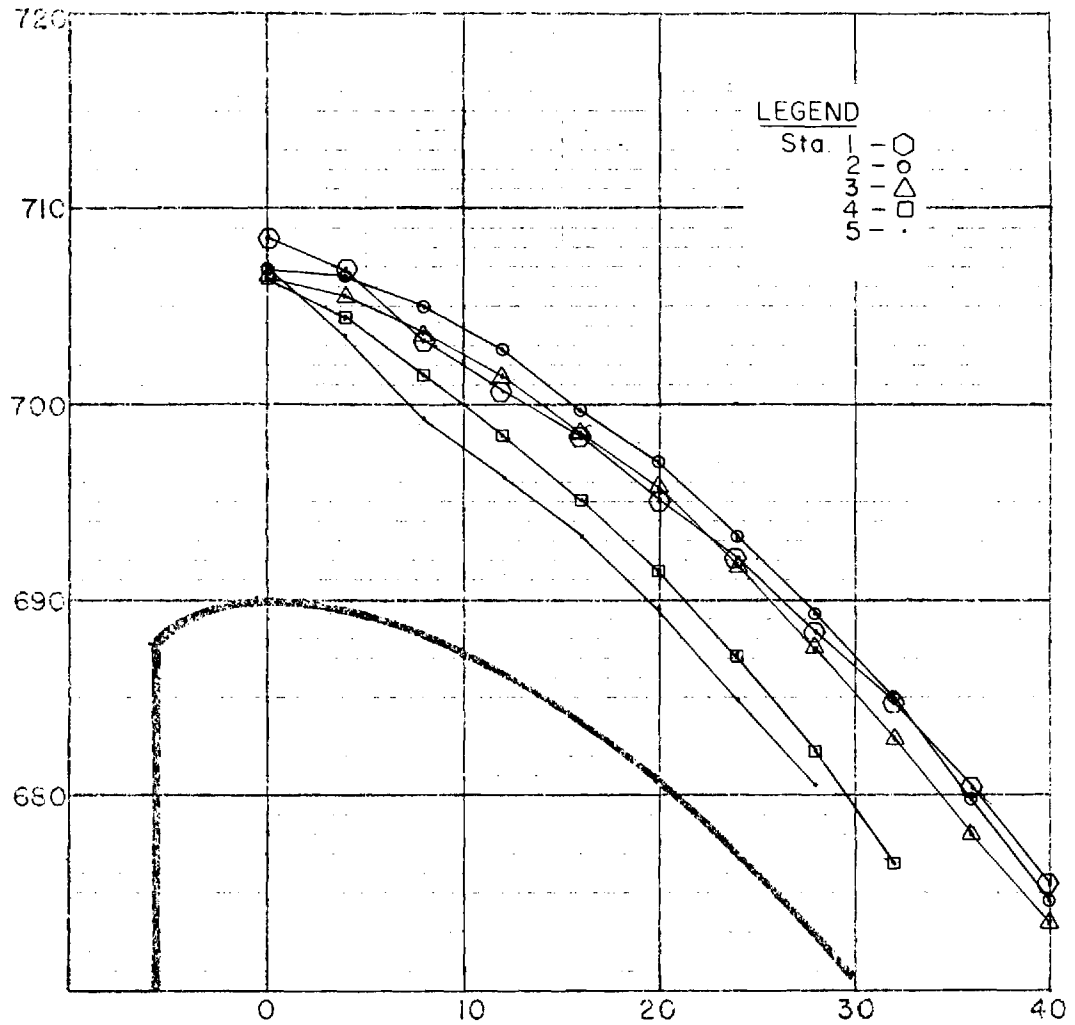

FIGURE 43.
 ROCKY MOUNTAIN PROJECT
 MAIN SPILLWAY MODEL STUDY
 1:40 SCALE MODEL

MODEL III, WATER SURFACE PROFILE

BAY NO. 3
 Q = 37,210 c.f.s.
 Res. El. = 710.0'

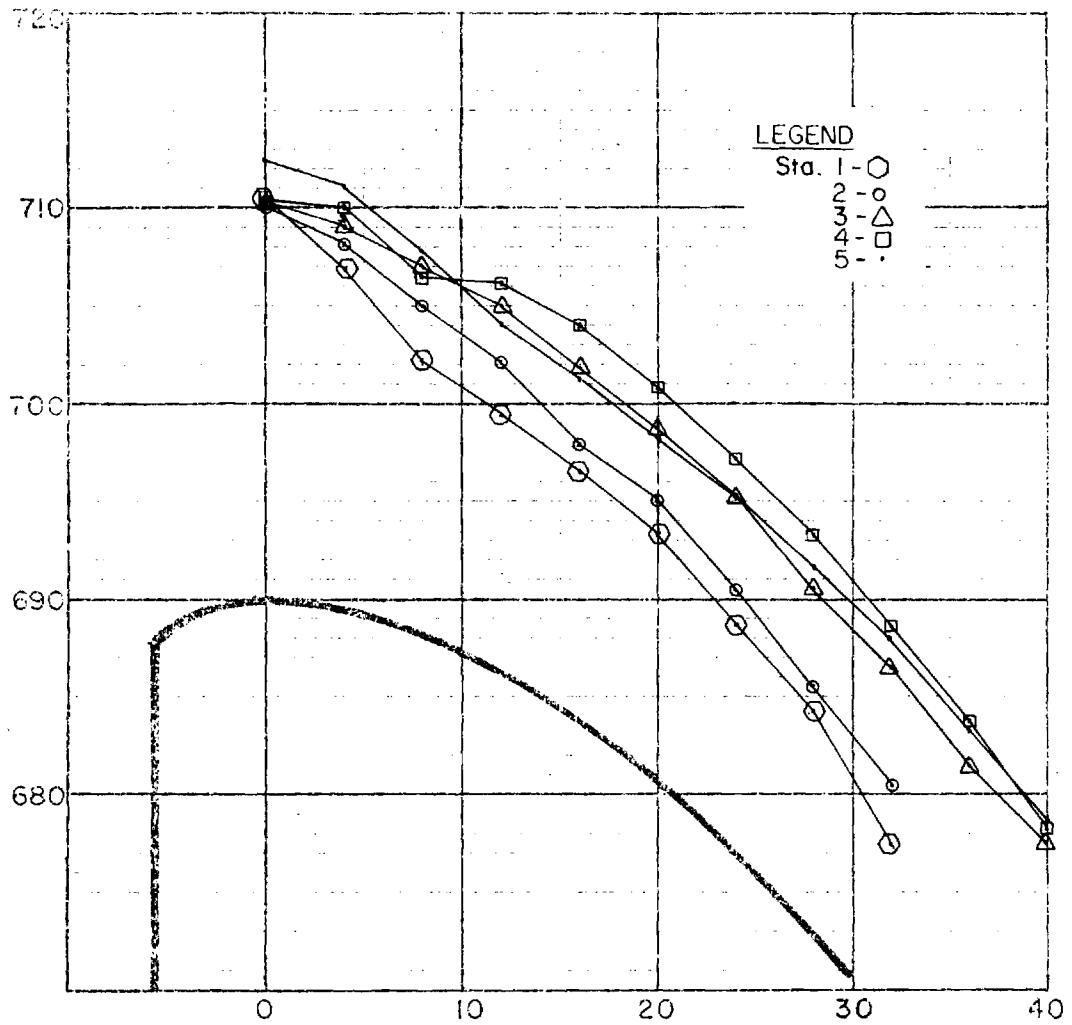

FIGURE 44.
 ROCKY MOUNTAIN PROJECT
 MAIN SPILLWAY MODEL STUDY
 1:40 SCALE MODEL

MODEL III, WATER SURFACE PROFILE

BAY NO. 1
 Q = 48,060 cfs.
 Res. El. = 714.1'

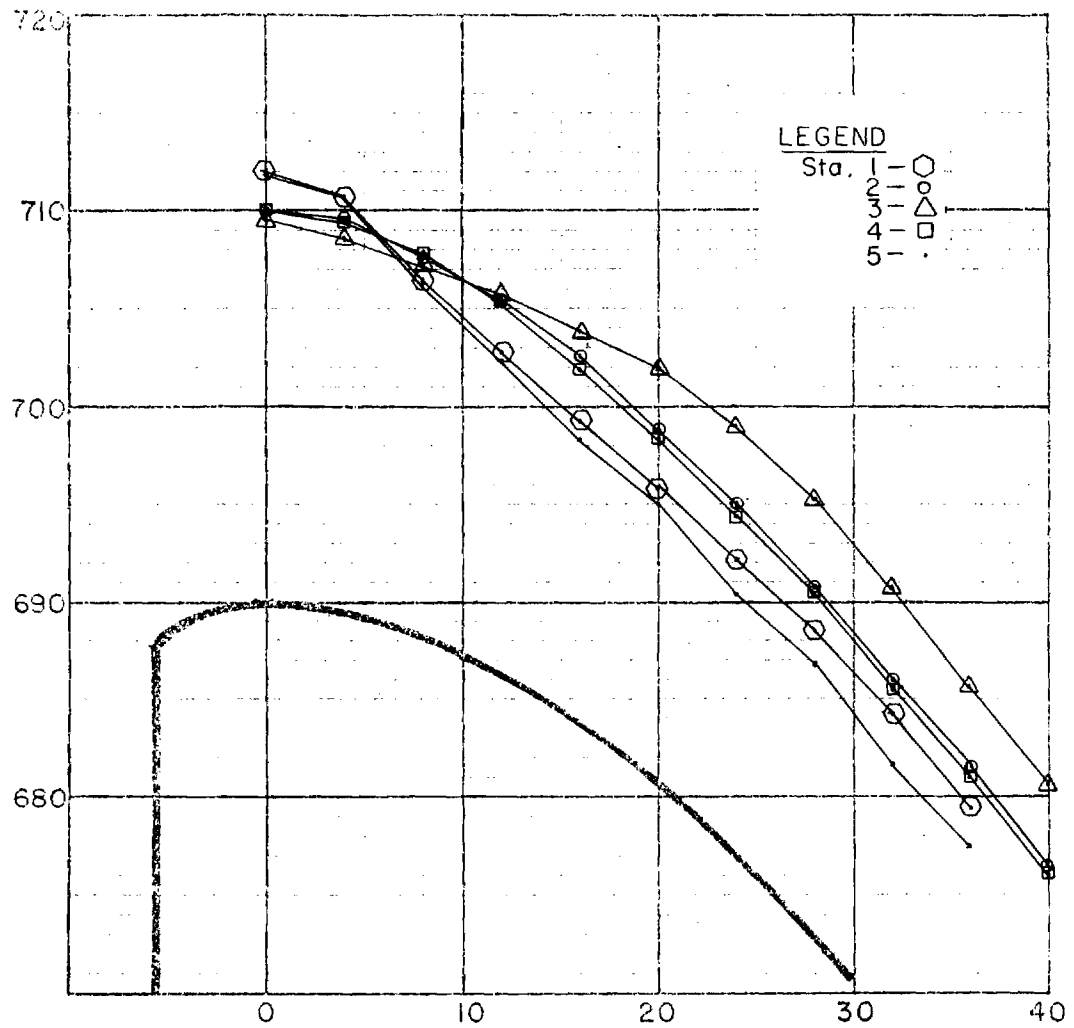

FIGURE 45.
 ROCKY MOUNTAIN PROJECT
 MAIN SPILLWAY MODEL STUDY
 1:40 SCALE MODEL

MODEL III, WATER SURFACE PROFILE

BAY NO. 2
 Q = 48,060 cfs.
 Res. El. = 714.1'

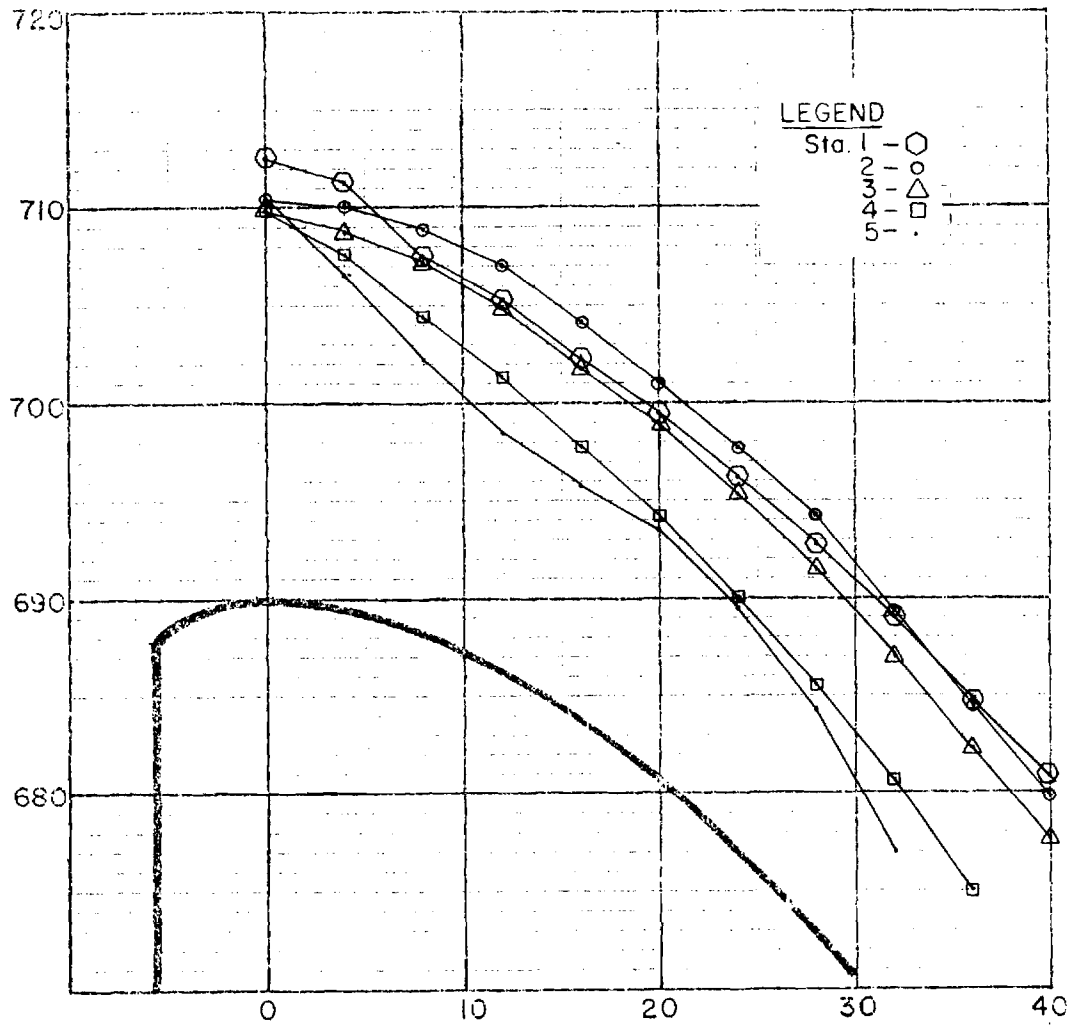

FIGURE 46.
 ROCKY MOUNTAIN PROJECT
 MAIN SPILLWAY MODEL STUDY
 1:40 SCALE MODEL

MODEL III, WATER SURFACE PROFILE

BAY NO. 3
 Q = 48,060 cfs.
 Res. El. = 714.1'

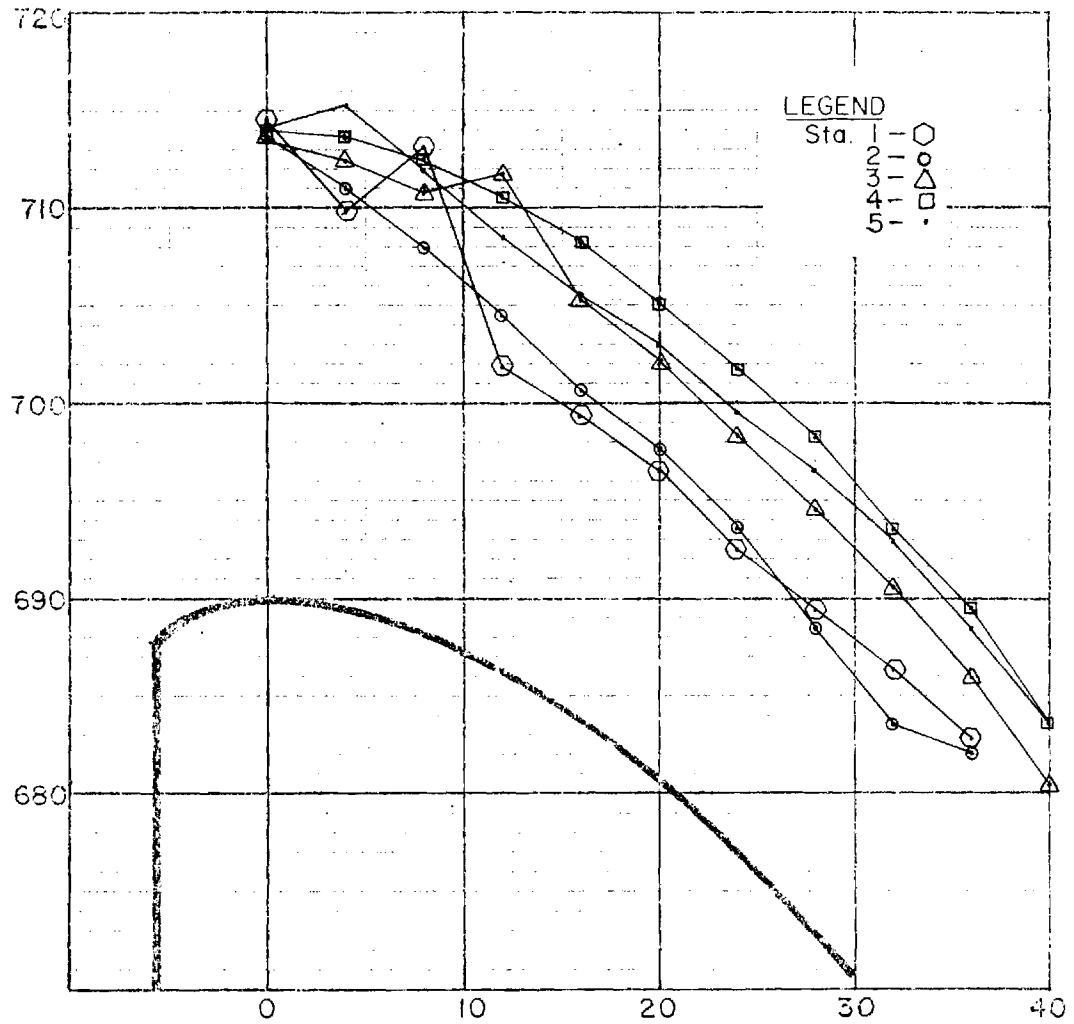

FIGURE 47.
 ROCKY MOUNTAIN PROJECT
 MAIN SPILLWAY MODEL STUDY
 1:40 SCALE MODEL

MODEL III, WATER SURFACE PROFILE

BAY NO. I
 Q = 57,560 cfs.
 Res. El. = 718.0'

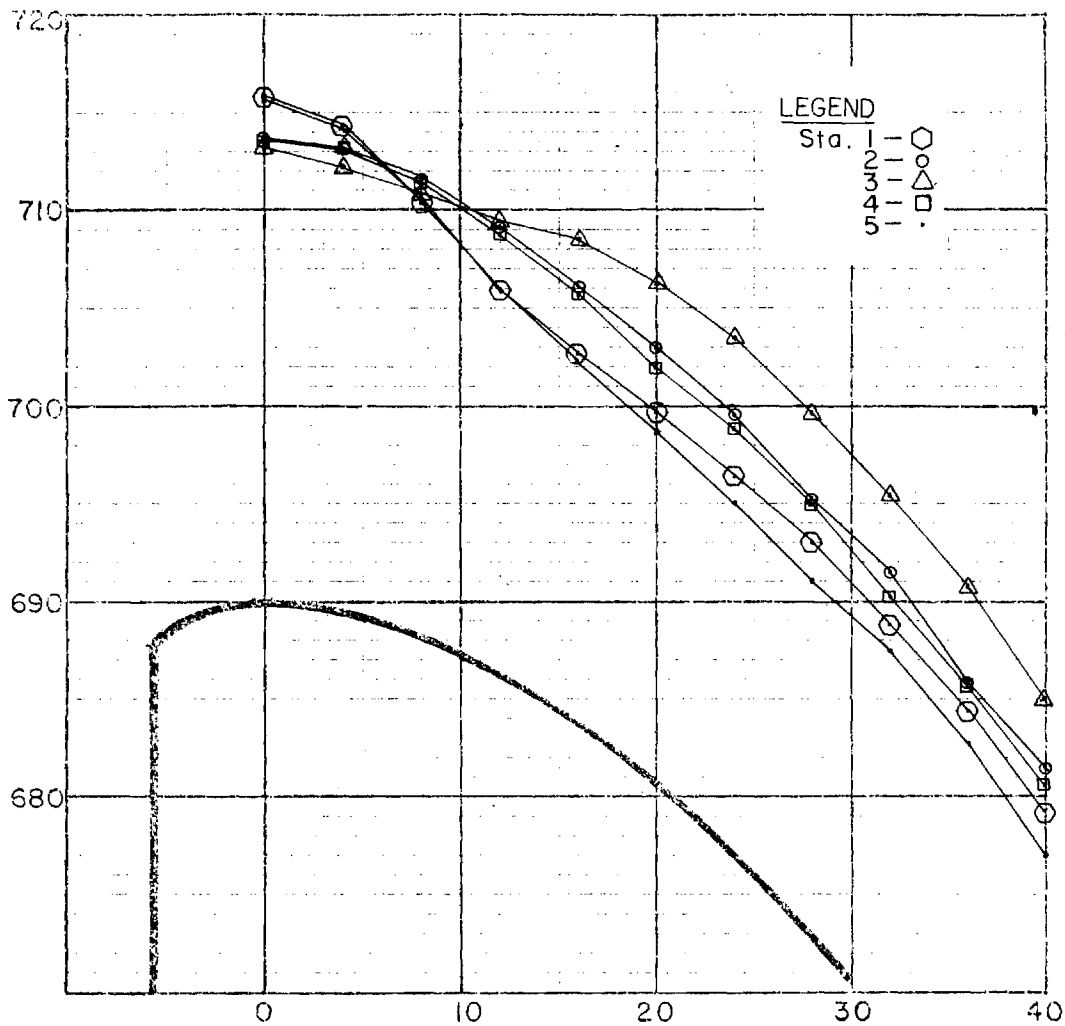

FIGURE 48.
 ROCKY MOUNTAIN PROJECT
 MAIN SPILLWAY MODEL STUDY
 1:40 SCALE MODEL

MODEL III, WATER SURFACE PROFILE

BAY NO. 2
 Q = 57,560 cfs.
 Res. El. = 718.0'

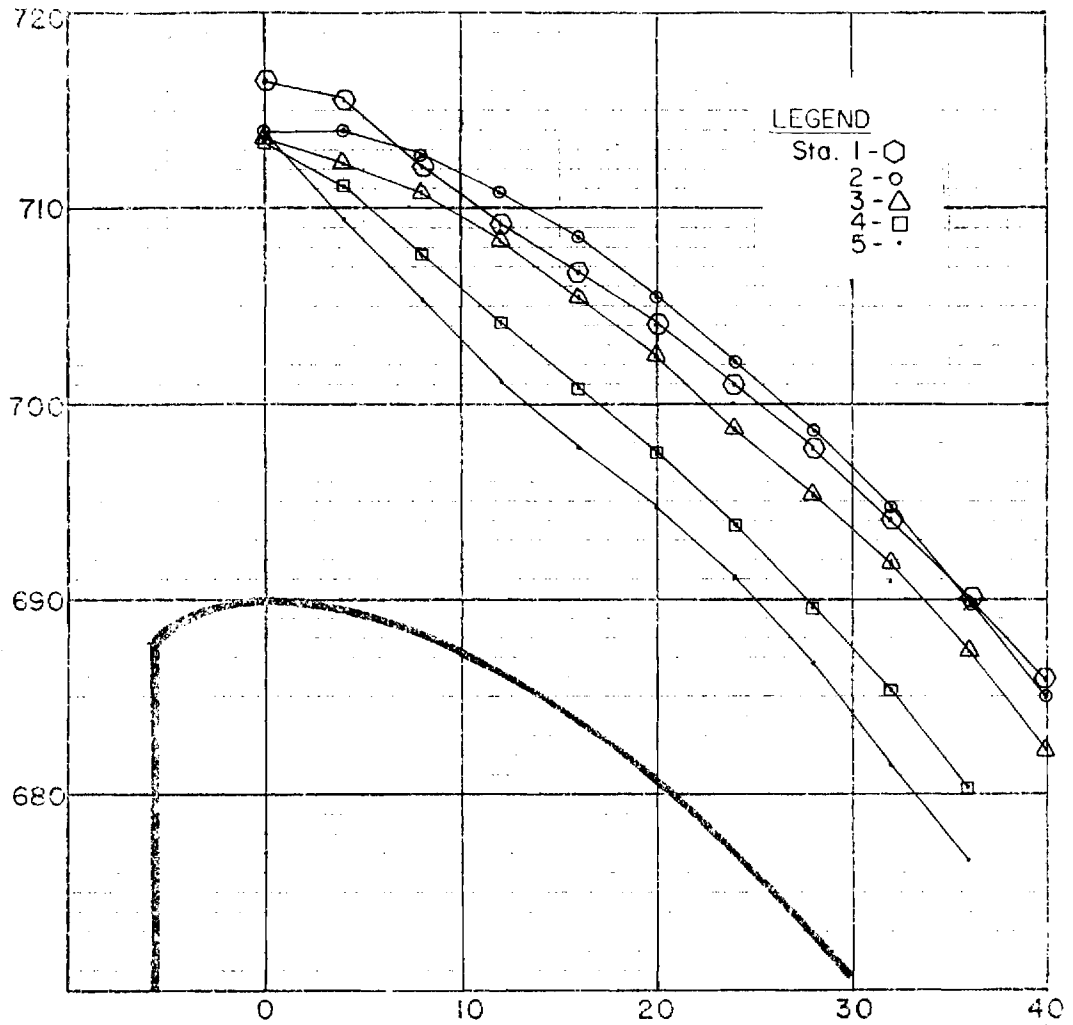

FIGURE 49.
 ROCKY MOUNTAIN PROJECT
 MAIN SPILLWAY MODEL STUDY
 1:40 SCALE MODEL

MODEL III, WATER SURFACE PROFILE

BAY NO. 3
 Q = 57,560 c.f.s.
 Res. El. = 718.0'

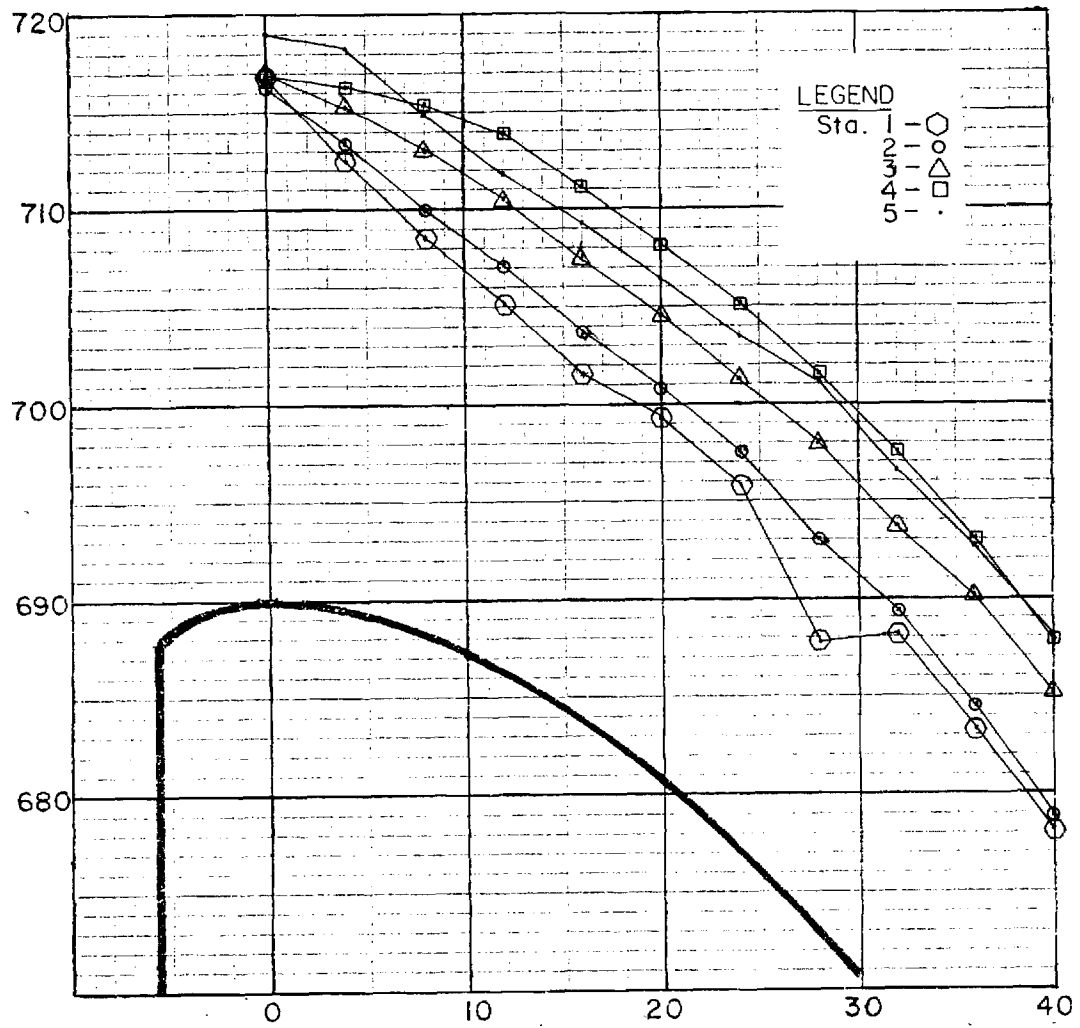

FIGURE 50.
 ROCKY MOUNTAIN PROJECT
 MAIN SPILLWAY MODEL STUDY
 1:40 SCALE MODEL

MODEL III, WATER SURFACE PROFILE

BAY NO. I
 Q = 66,450 cfs.
 Res. El. = 720.9'

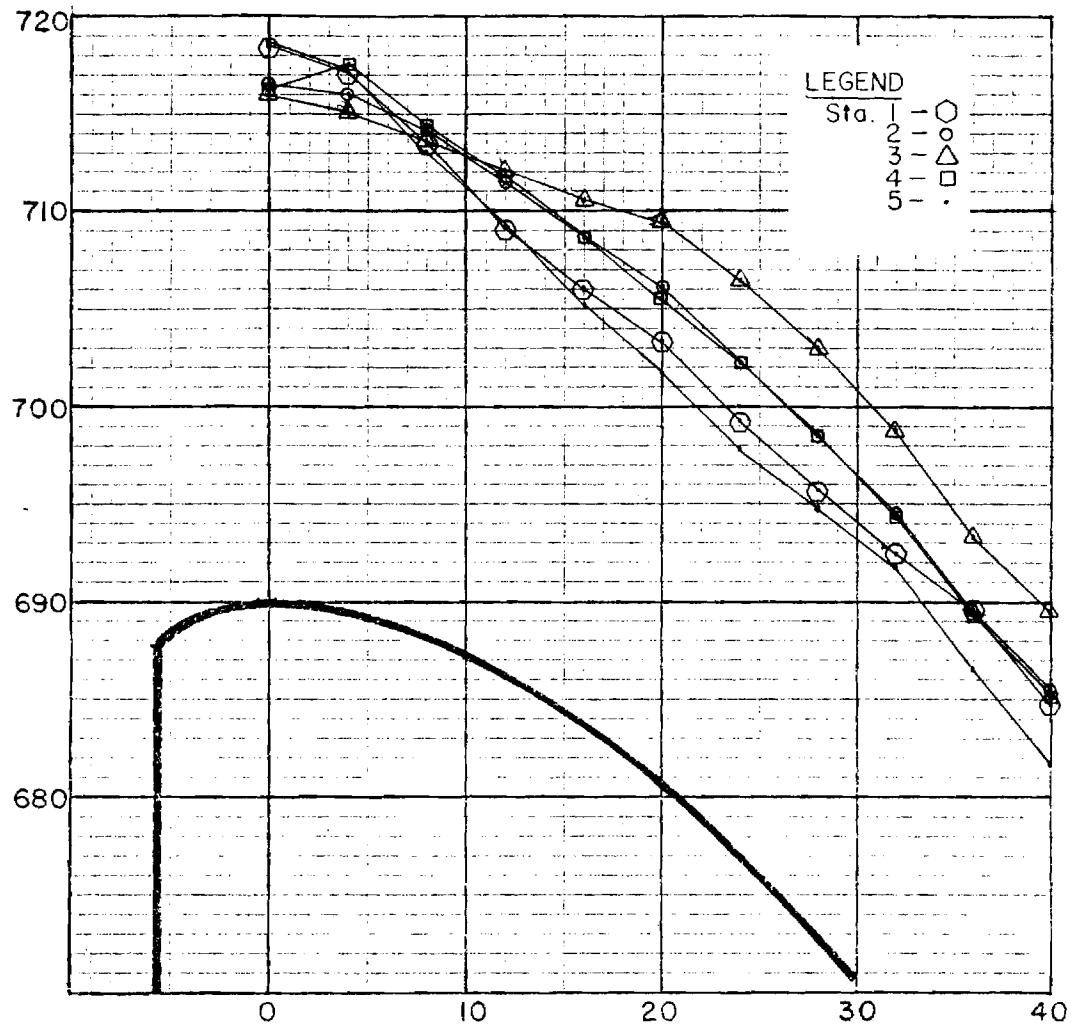

FIGURE 51.
 ROCKY MOUNTAIN PROJECT
 MAIN SPILLWAY MODEL STUDY
 1:40 SCALE MODEL

MODEL III, WATER SURFACE PROFILE

BAY NO. 2
 Q = 66,450 cfs.
 Res. El. = 720.9'

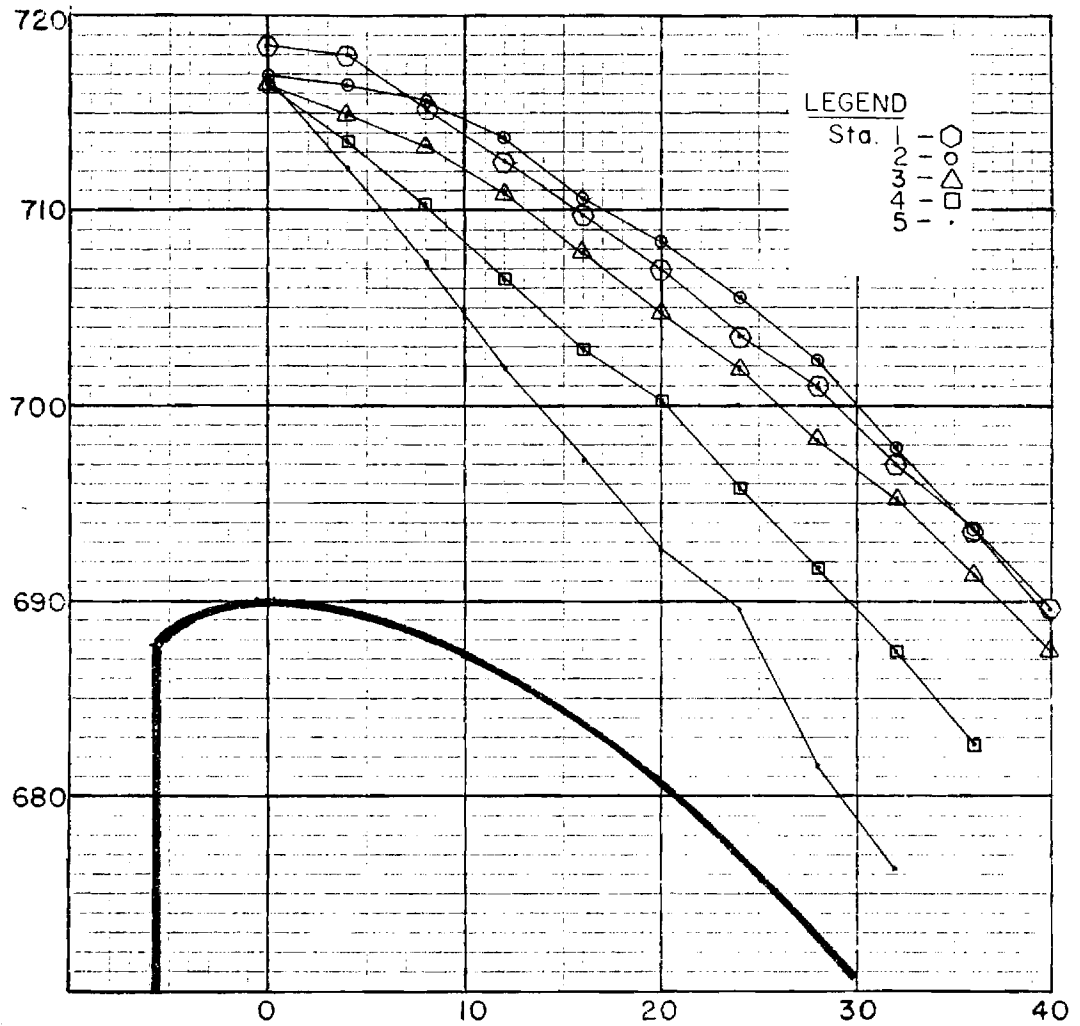

FIGURE 52.
 ROCKY MOUNTAIN PROJECT
 MAIN SPILLWAY MODEL STUDY
 1:40 SCALE MODEL

MODEL III, WATER SURFACE PROFILE

BAY NO. 3
 Q = 66,450 cfs
 Res. El. = 720.9'

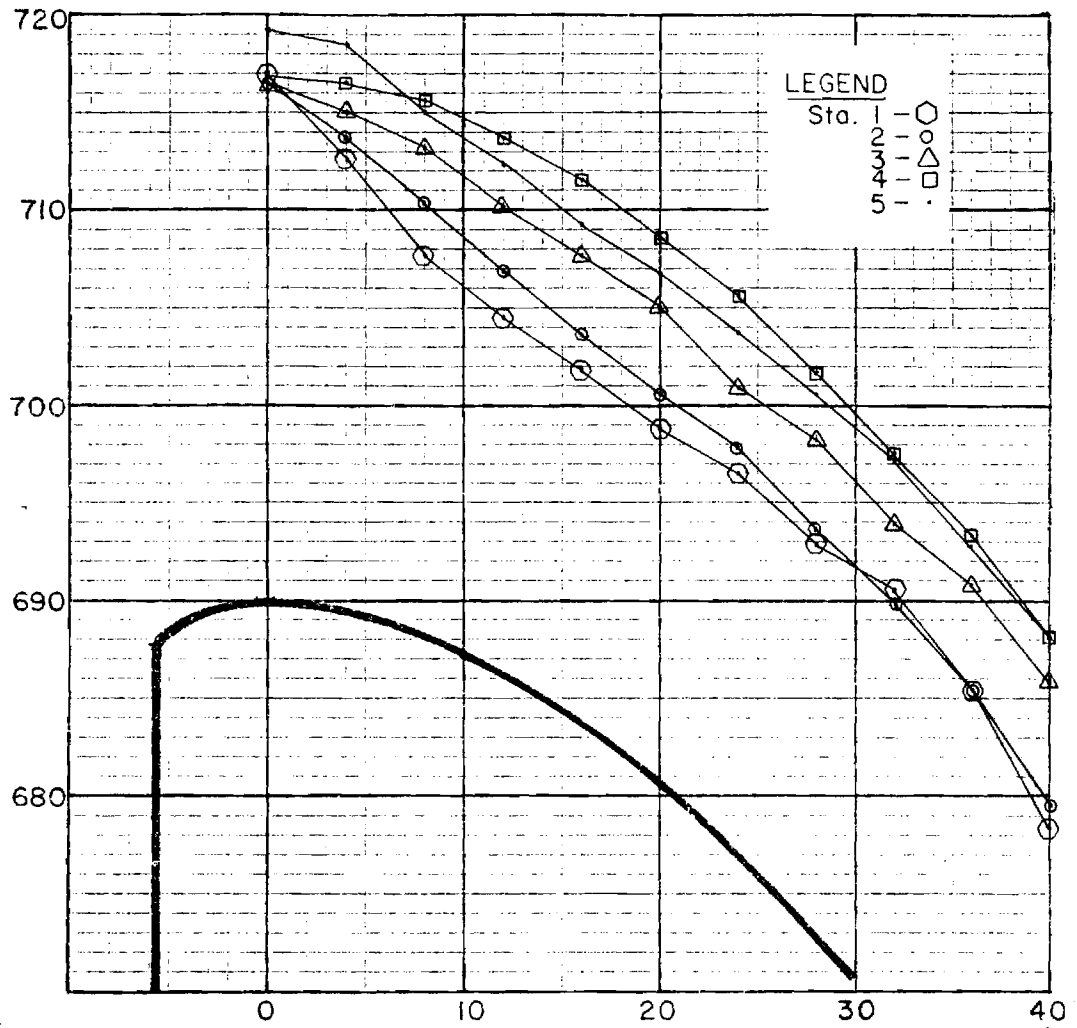

FIGURE 53.
 ROCKY MOUNTAIN PROJECT
 MAIN SPILLWAY MODEL STUDY
 1:40 SCALE MODEL

MODEL III, WATER SURFACE PROFILE

BAY NO. I
 Q = 69,560 cfs
 Res. El. = 721.0'

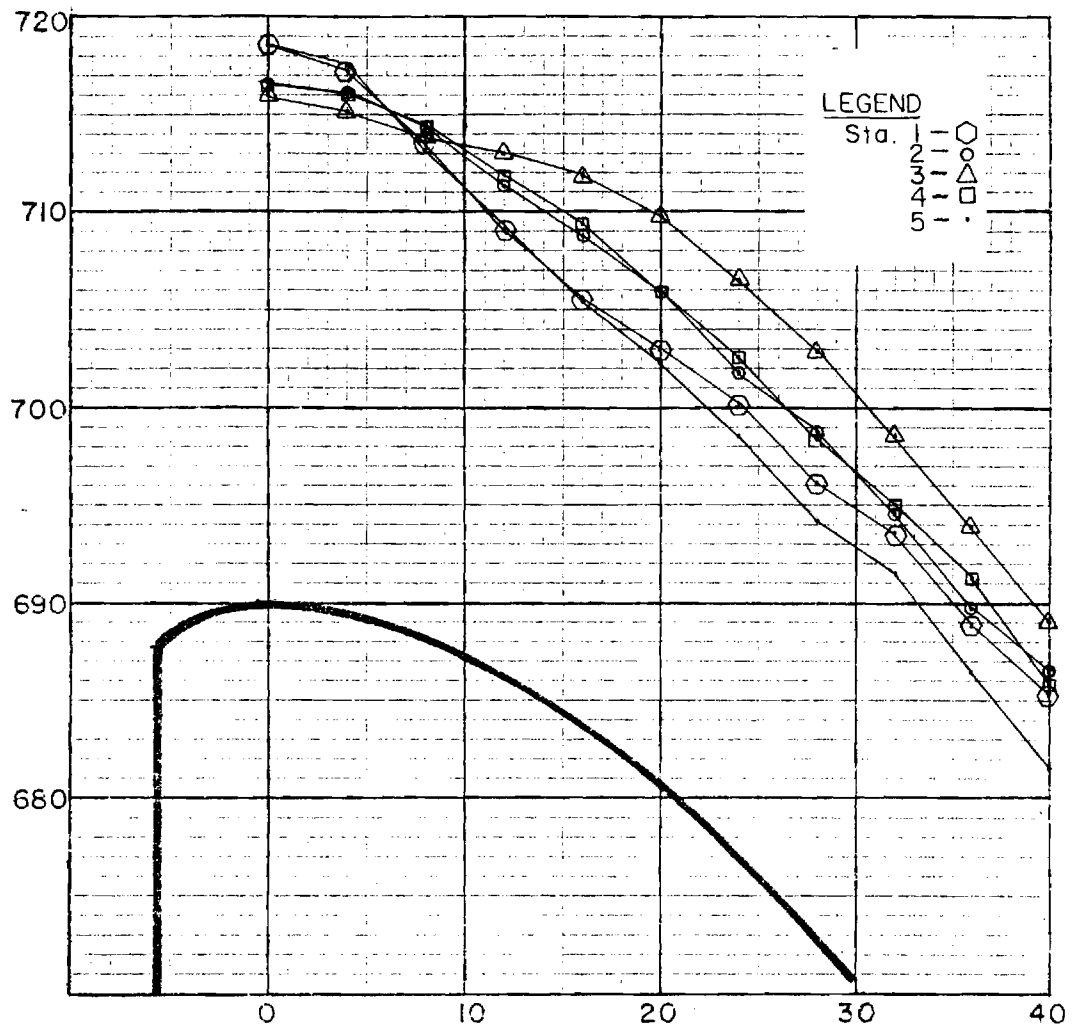

FIGURE 54.
 ROCKY MOUNTAIN PROJECT
 MAIN SPILLWAY MODEL STUDY
 1:40 SCALE MODEL

MODEL III, WATER SURFACE PROFILE

BAY NO. 2
 Q = 69,560 cfs
 Res. El. = 721.0'

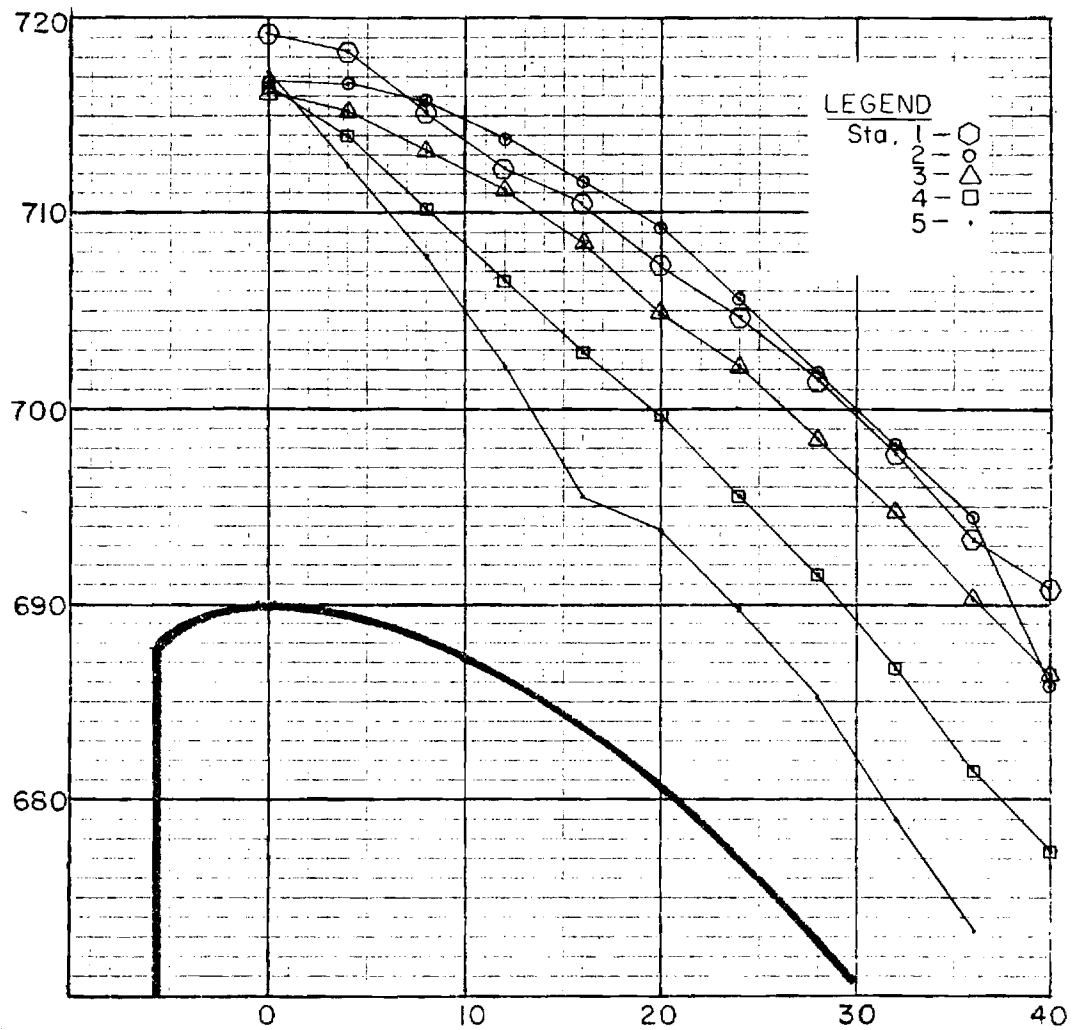

FIGURE 55.
 ROCKY MOUNTAIN PROJECT
 MAIN SPILLWAY MODEL STUDY
 1:40 SCALE MODEL

MODEL III, WATER SURFACE PROFILE

BAY NO. 3
 Q = 69,560 cfs
 Res. El. = 721.0'

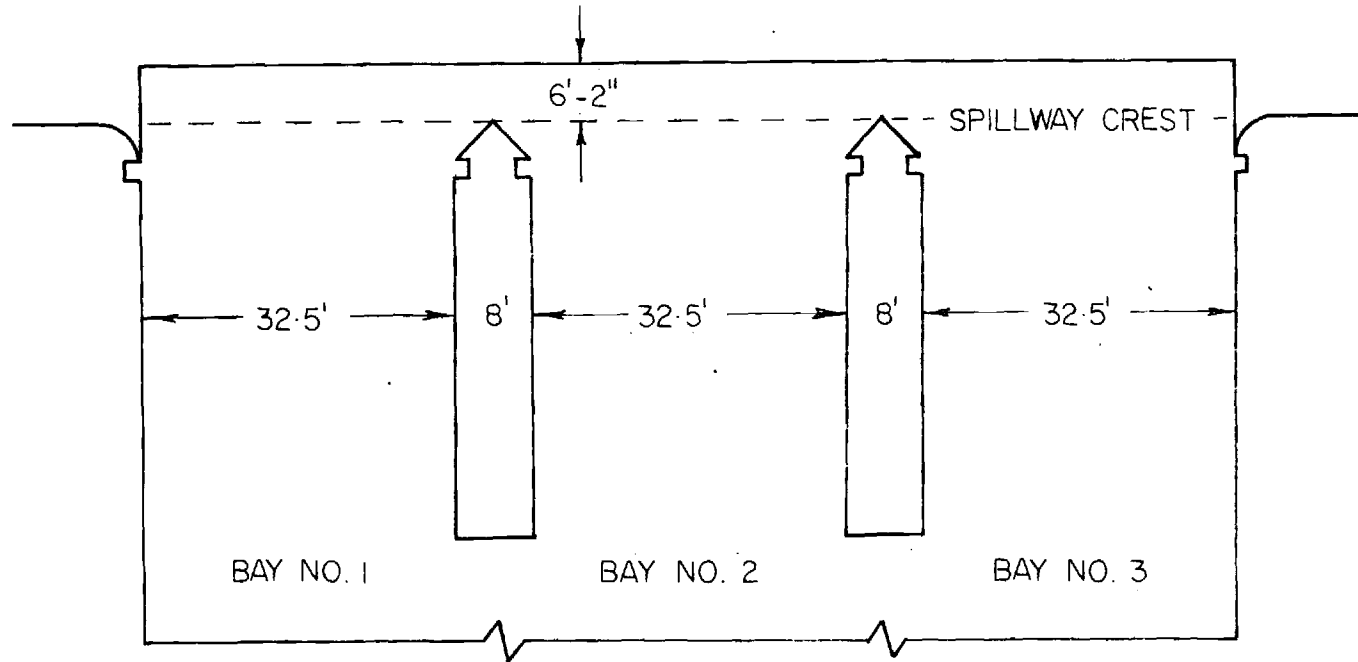

FIGURE 56.
ROCKY MOUNTAIN PROJECT
MAIN SPILLWAY MODEL STUDY
1:40 SCALE MODEL

MODEL V, PLAN VIEW

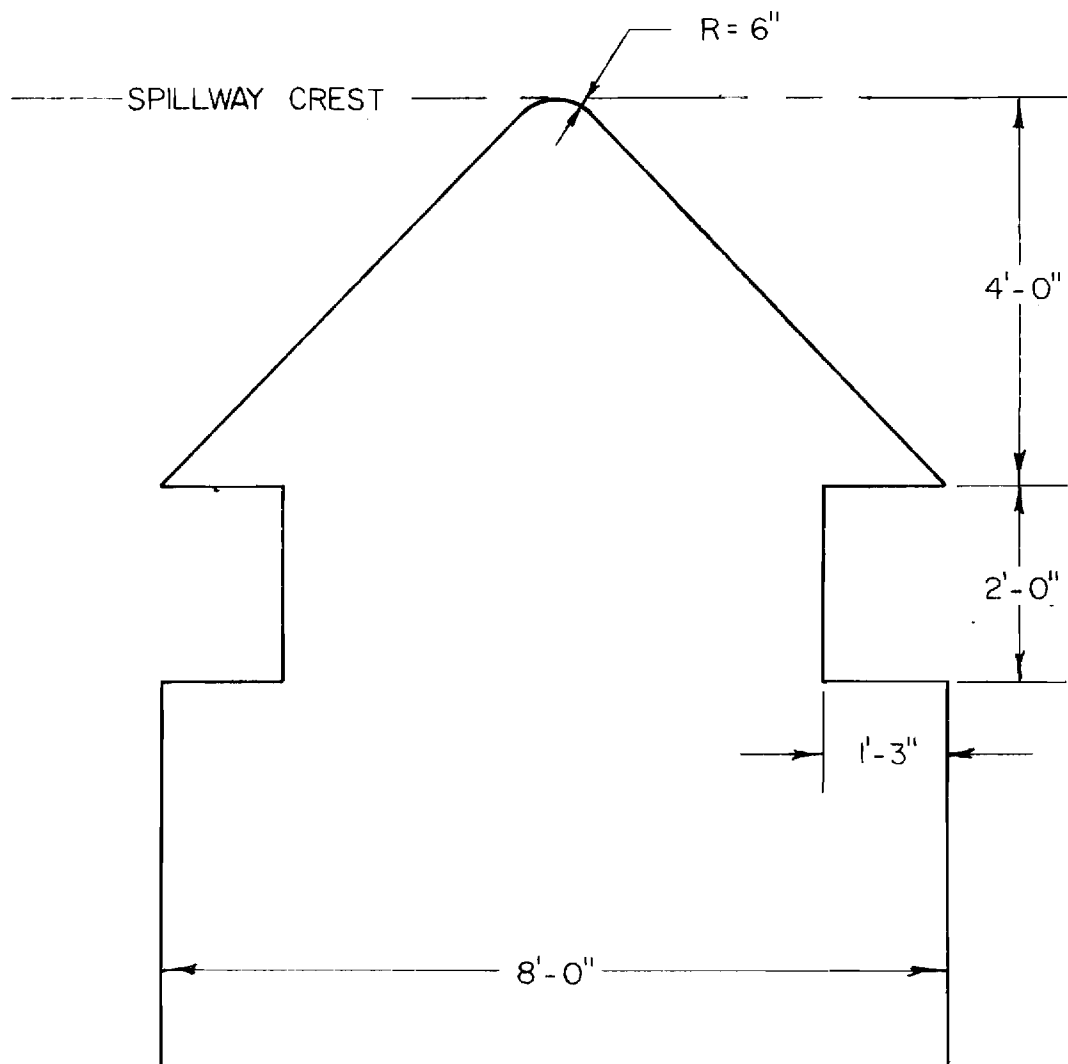

FIGURE 57.
 ROCKY MOUNTAIN PROJECT
 MAIN SPILLWAY MODEL STUDY
 1:40 SCALE MODEL

MODEL V, DETAIL OF INTERIOR PIER

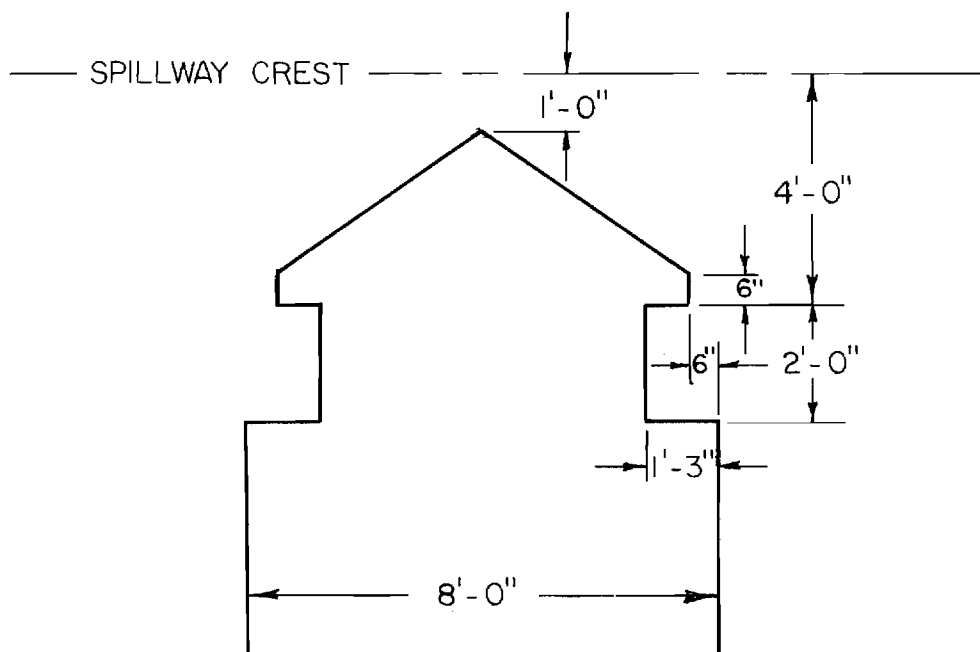

FIGURE 58.
 ROCKY MOUNTAIN PROJECT
 MAIN SPILLWAY MODEL STUDY
 1:40 SCALE MODEL

MODEL VIII
 DETAIL OF INTERIOR PIER

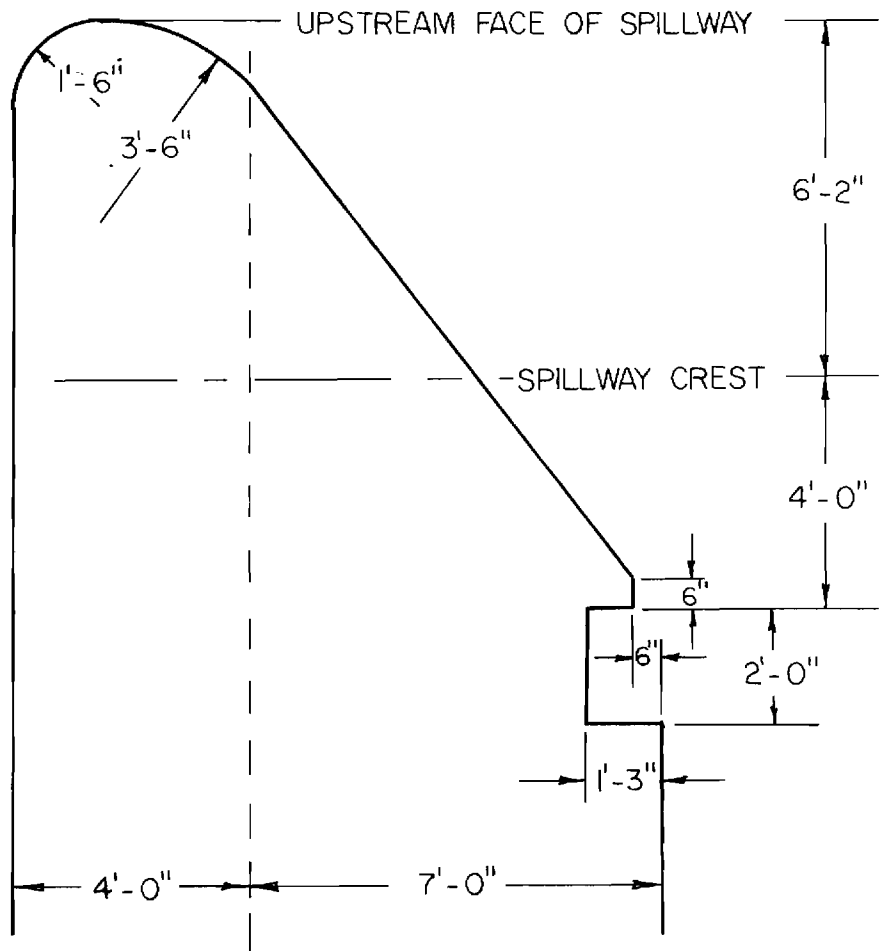

FIGURE 59.
 ROCKY MOUNTAIN PROJECT
 MAIN SPILLWAY MODEL STUDY
 1:40 SCALE MODEL

MODEL VIII
 DETAIL OF END PIER

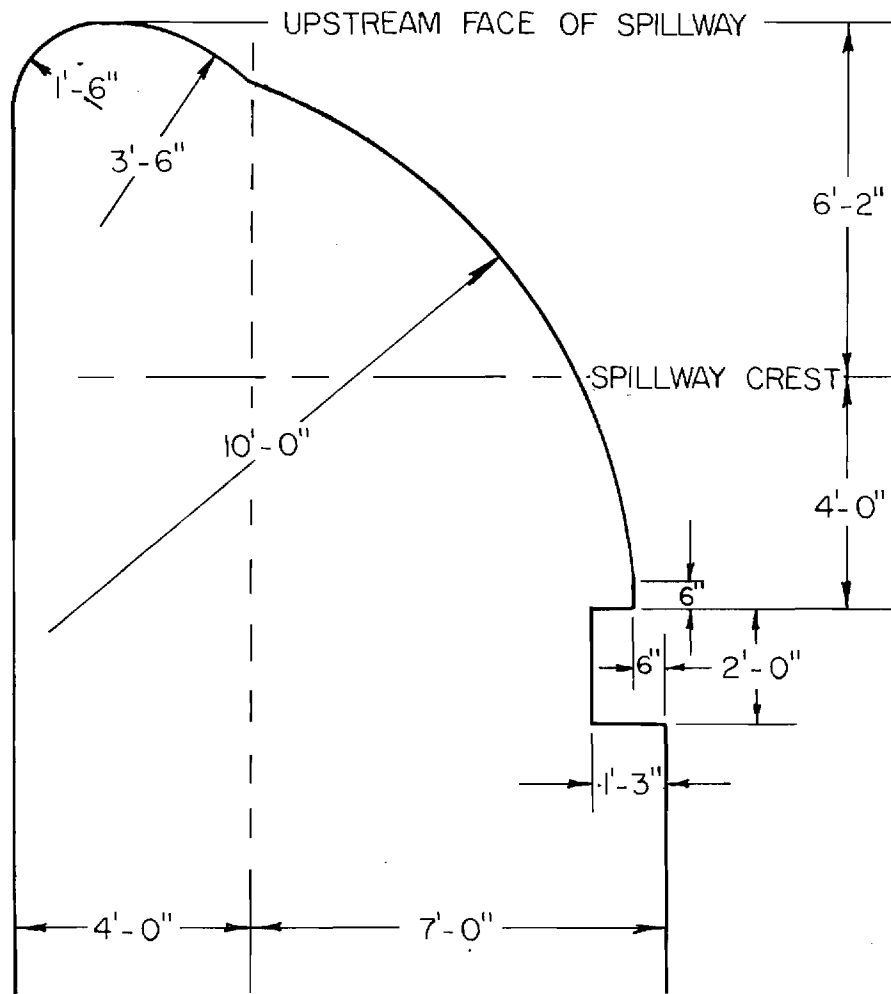

FIGURE 60.
 ROCKY MOUNTAIN PROJECT
 MAIN SPILLWAY MODEL STUDY
 1:40 SCALE MODEL

MODEL IX
 DETAIL OF END PIER

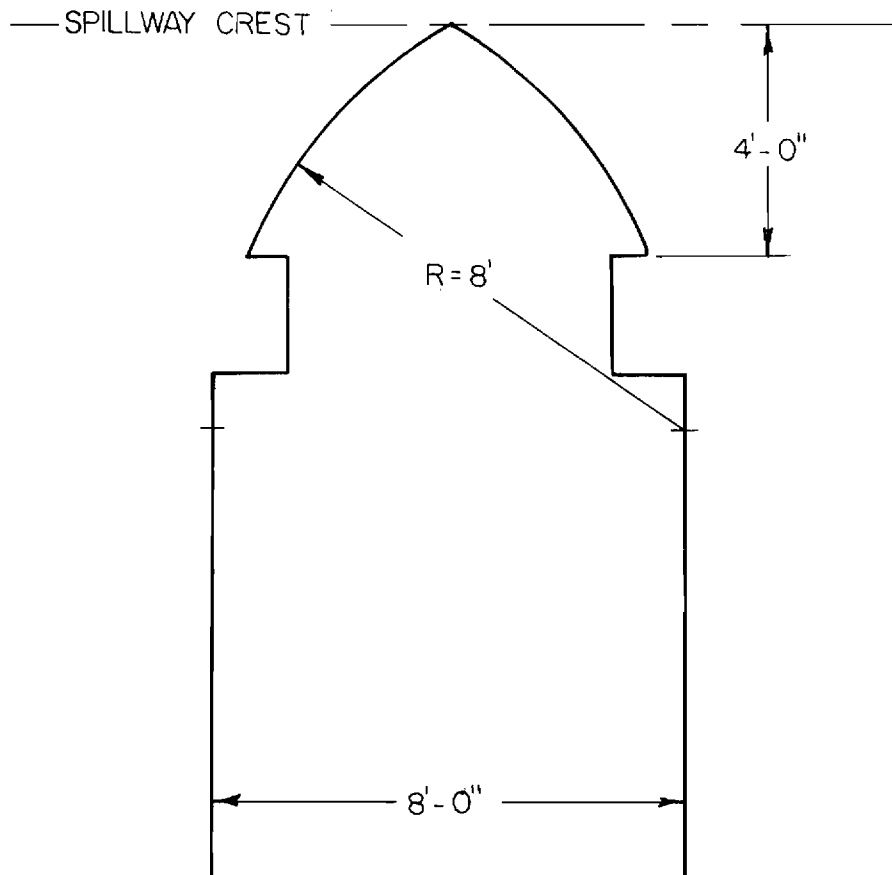

FIGURE 6I.
ROCKY MOUNTAIN PROJECT
MAIN SPILLWAY MODEL STUDY
1:40 SCALE MODEL

MODEL X, DETAIL OF INTERIOR PIER

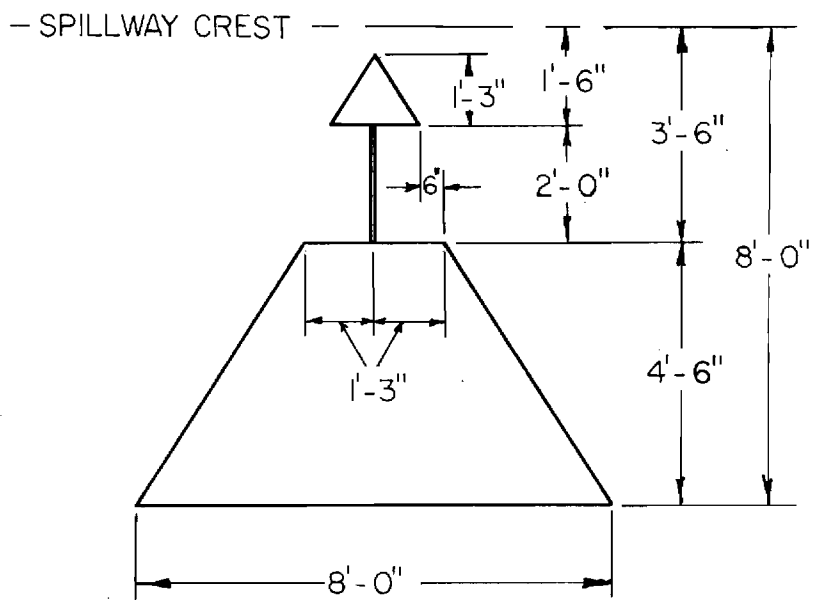

FIGURE 62.
 ROCKY MOUNTAIN PROJECT
 MAIN SPILLWAY MODEL STUDY
 1:40 SCALE MODEL

MODEL XII, DETAIL OF INTERIOR PIER

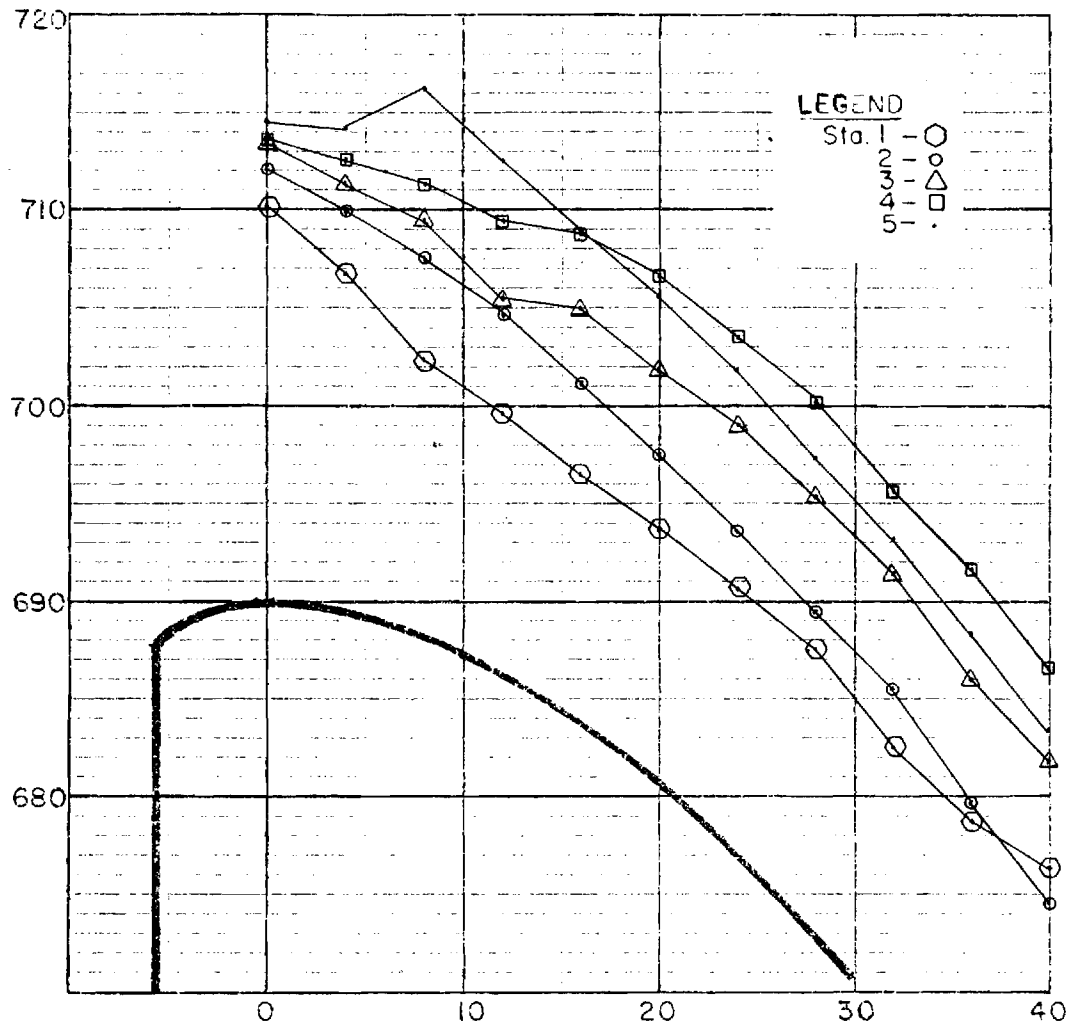

FIGURE 63.
 ROCKY MOUNTAIN PROJECT
 MAIN SPILLWAY MODEL STUDY
 1:40 SCALE MODEL

MODEL XII, WATER SURFACE PROFILE

BAY NO. 1
 Q = 63,720 cfs
 Res. El. = 718.8'

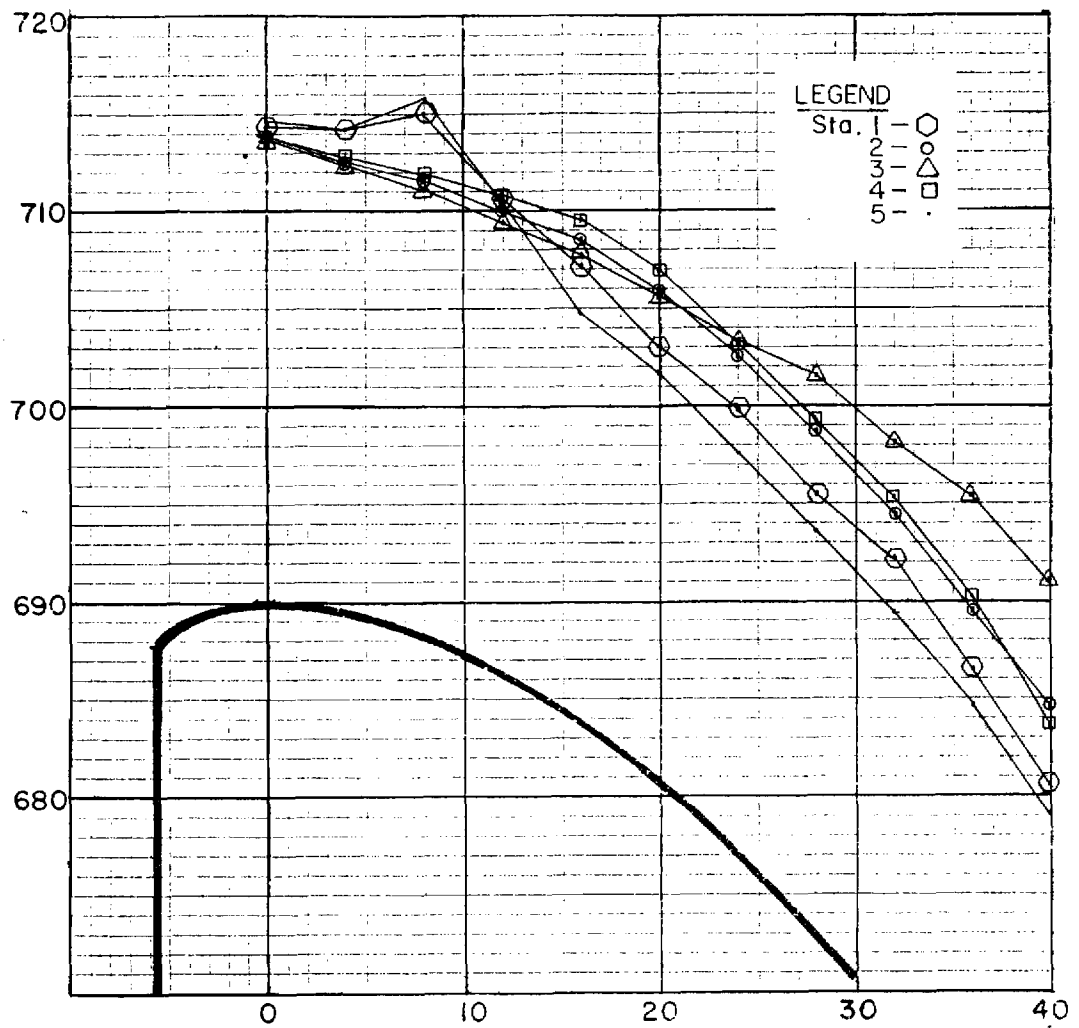

FIGURE 64.
 ROCKY MOUNTAIN PROJECT
 MAIN SPILLWAY MODEL STUDY
 1:40 SCALE MODEL

MODEL XII, WATER SURFACE PROFILE

BAY NO. 2
 Q = 63,720 cfs
 Res. El. = 718.8'

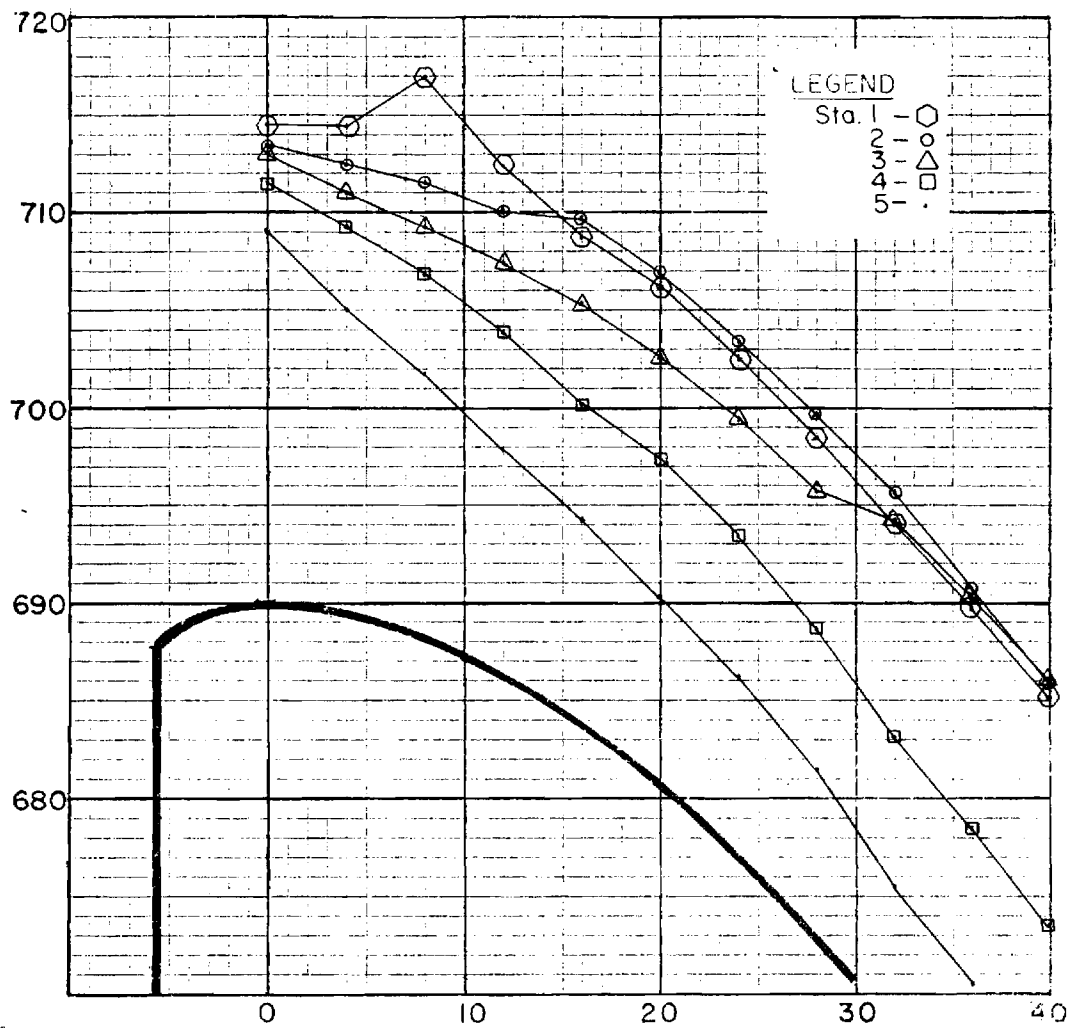

FIGURE 65.
 ROCKY MOUNTAIN PROJECT
 MAIN SPILLWAY MODEL STUDY
 1:40 SCALE MODEL

MODEL XII, WATER SURFACE PROFILE

BAY NO. 3
 Q = 63,720 cfs
 Res. El. = 718.8'

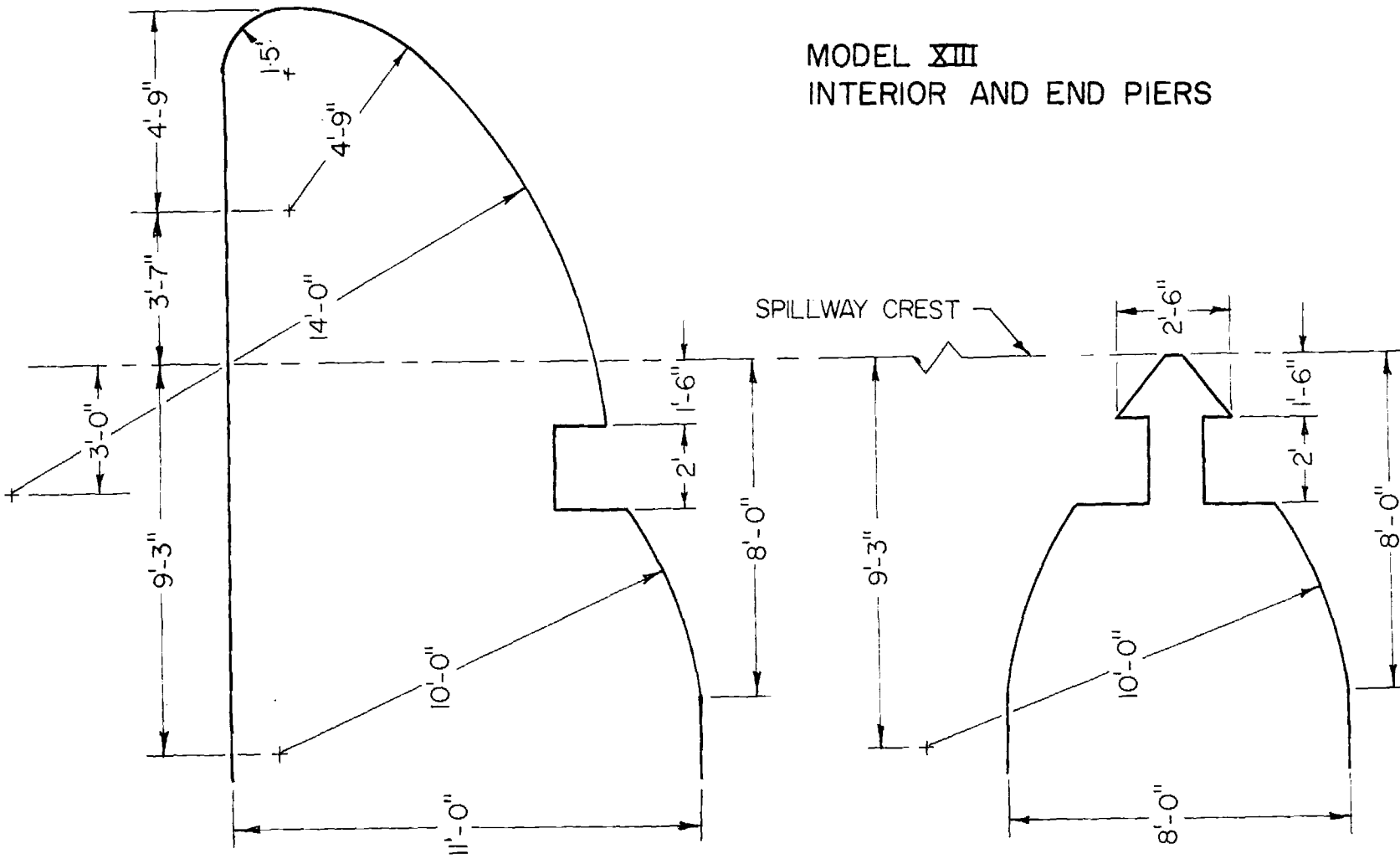

FIGURE 66.
ROCKY MOUNTAIN PROJECT
MAIN SPILLWAY MODEL STUDY
1:40 SCALE MODEL

MODEL XIII
INTERIOR AND END PIERS

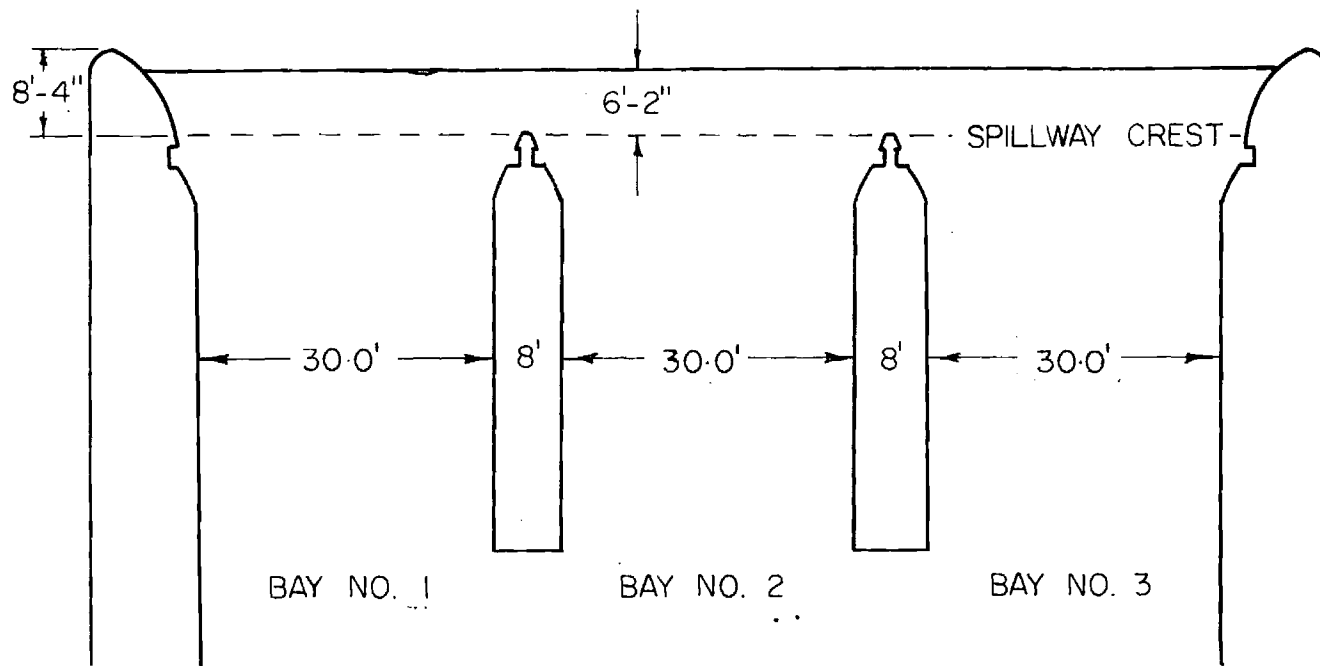

FIGURE 67.
 ROCKY MOUNTAIN PROJECT
 MAIN SPILLWAY MODEL STUDY
 1:40 SCALE MODEL

MODEL XIII, PLAN VIEW

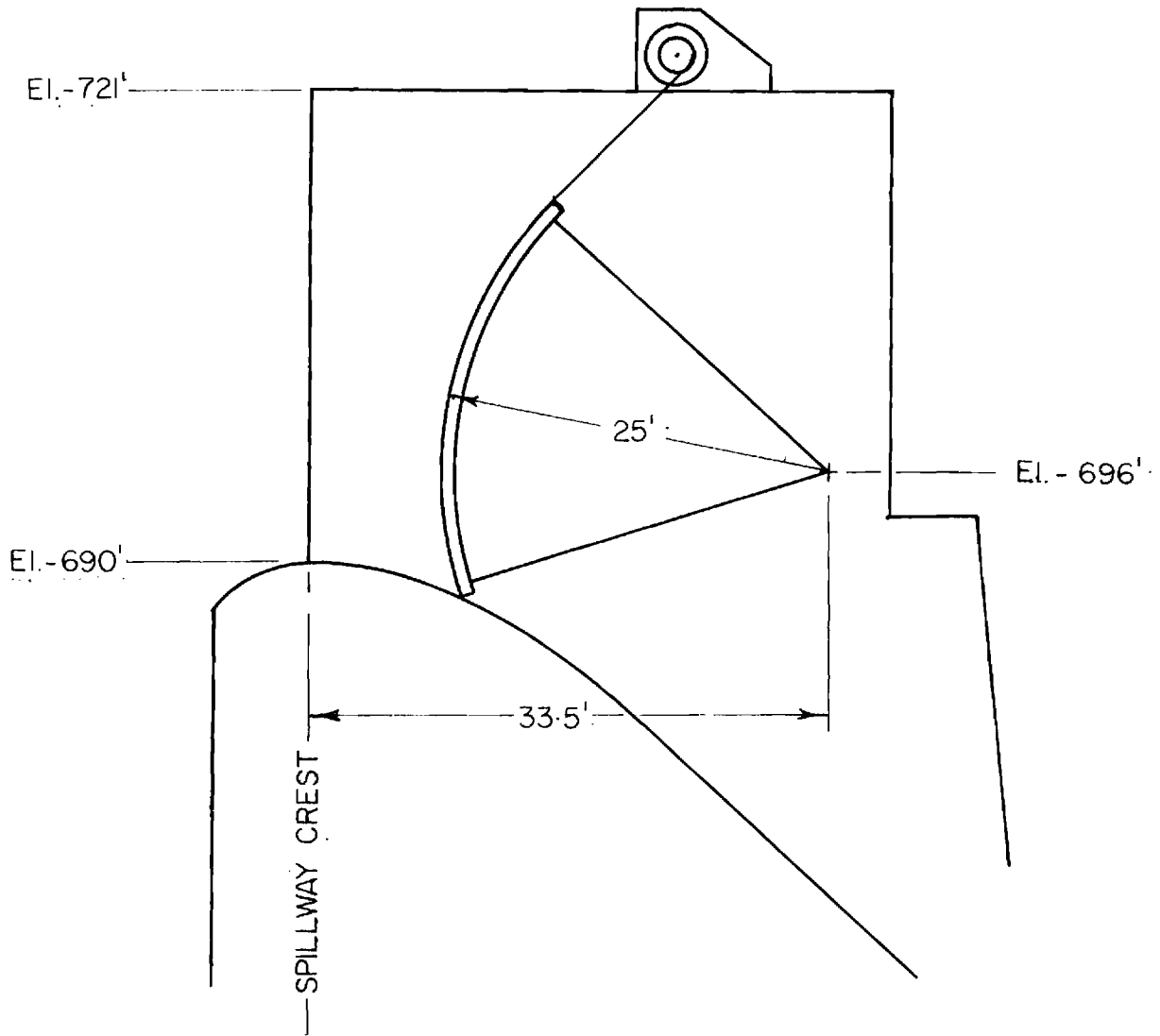

FIGURE 68.
 ROCKY MOUNTAIN PROJECT
 MAIN SPILLWAY MODEL STUDY
 1:40 SCALE MODEL

MODEL XIII
 GATE TRUNION DETAIL

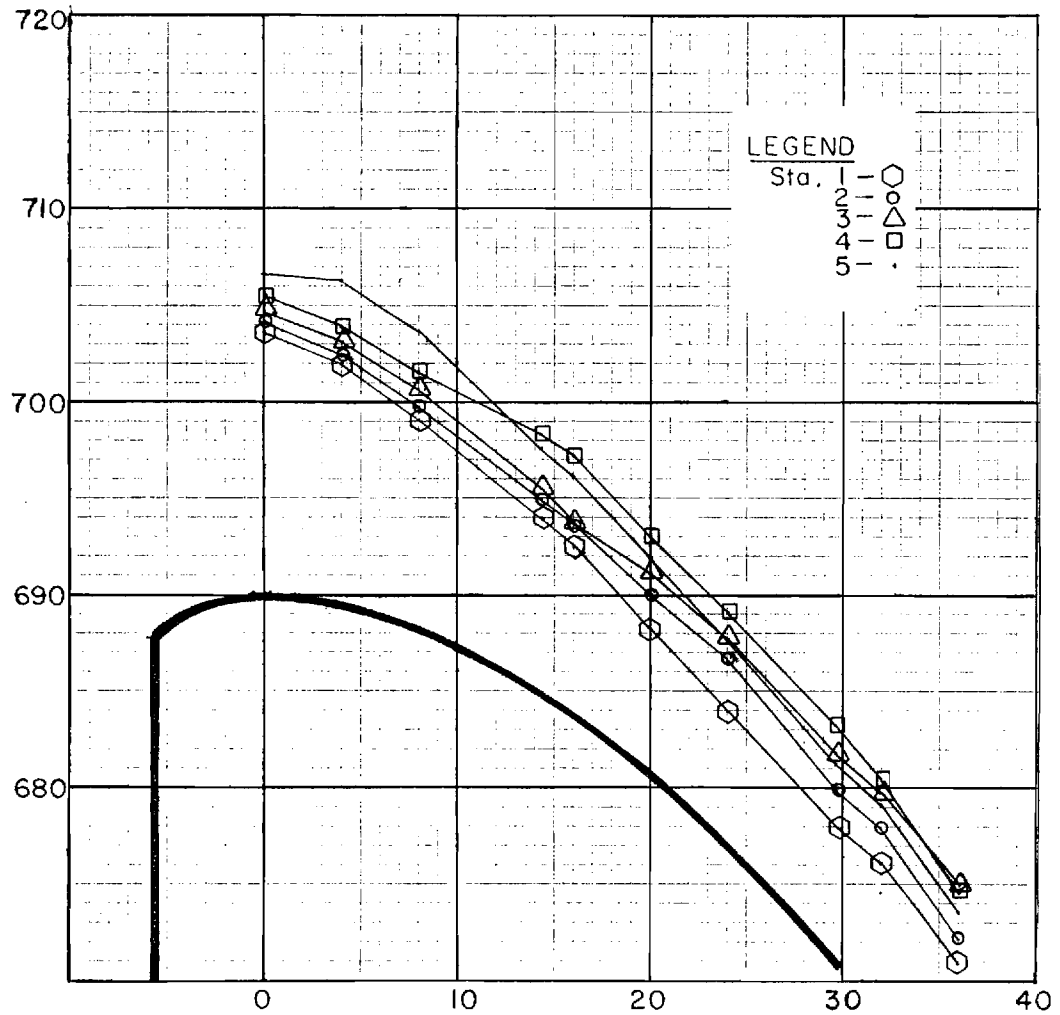

FIGURE 69.
 ROCKY MOUNTAIN PROJECT
 MAIN SPILLWAY MODEL STUDY
 1:40 SCALE MODEL

MODEL XIII, WATER SURFACE PROFILE

BAY NO. I
 Q = 40,700 cfs
 Res. El. = 712.5'

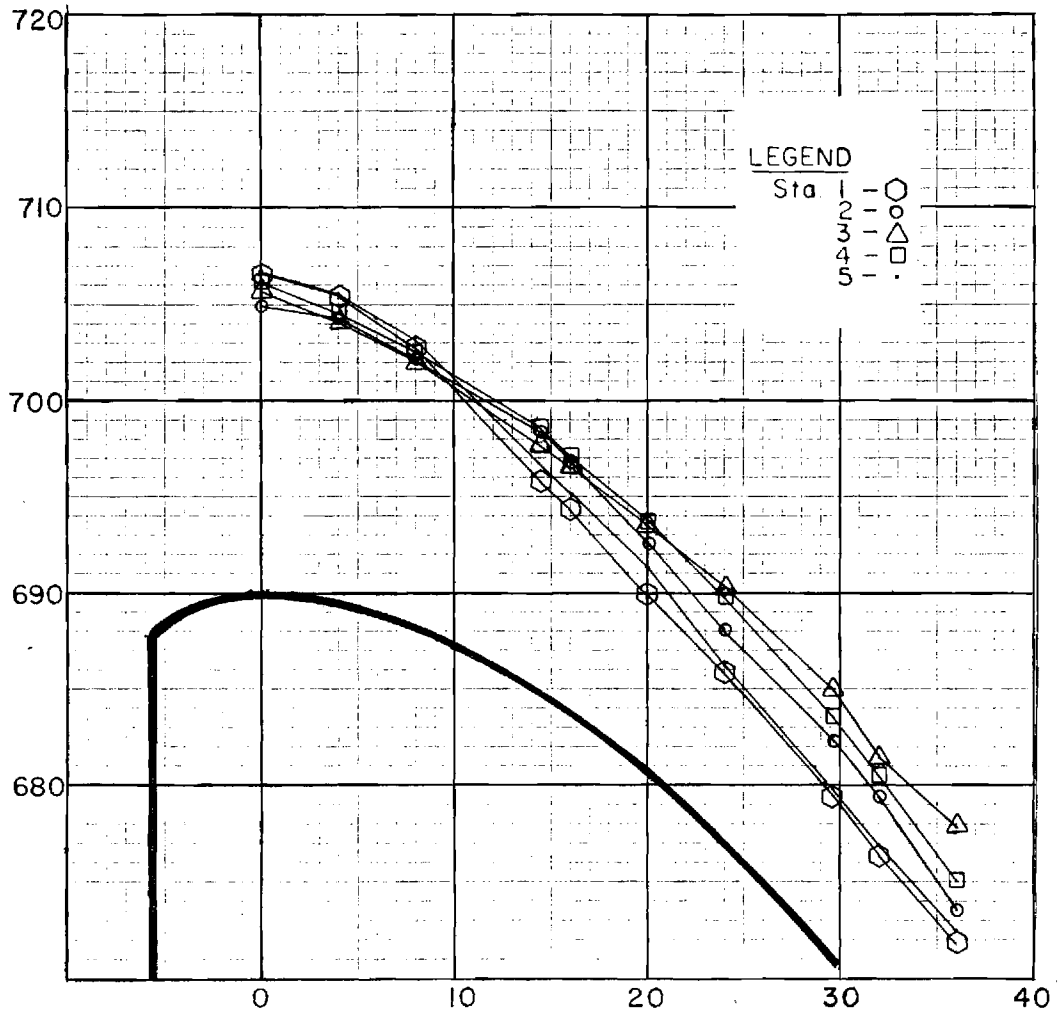

FIGURE 70.
 ROCKY MOUNTAIN PROJECT
 MAIN SPILLWAY MODEL STUDY
 1:40 SCALE MODEL

MODEL XIII, WATER SURFACE PROFILE

BAY NO. 2
 Q = 40,700 cfs
 Res. El. = 712.5'

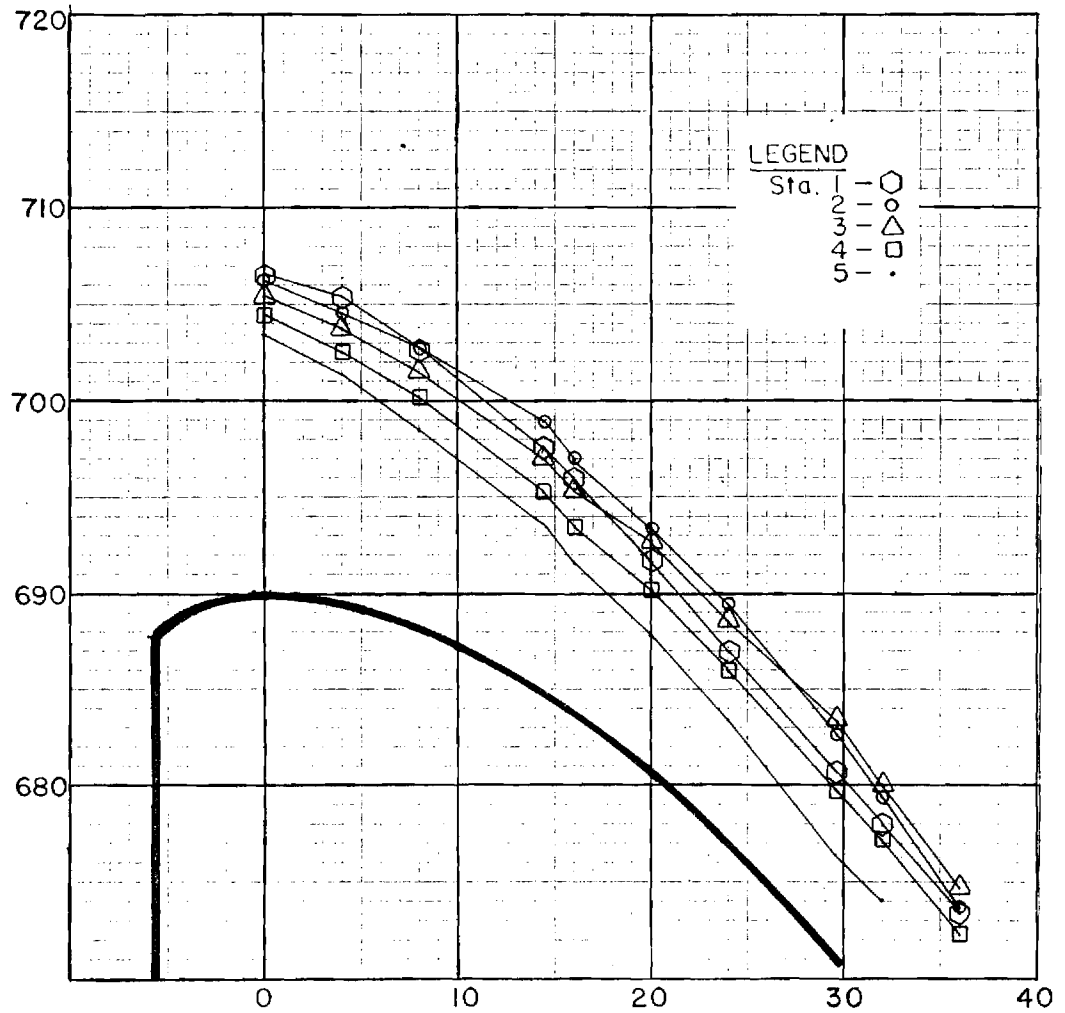

FIGURE 71.
 ROCKY MOUNTAIN PROJECT
 MAIN SPILLWAY MODEL STUDY
 1:40 SCALE MODEL

MODEL XIII, WATER SURFACE PROFILE

BAY NO. 3
 Q = 40,700 cfs
 Res. El. = 712.5'

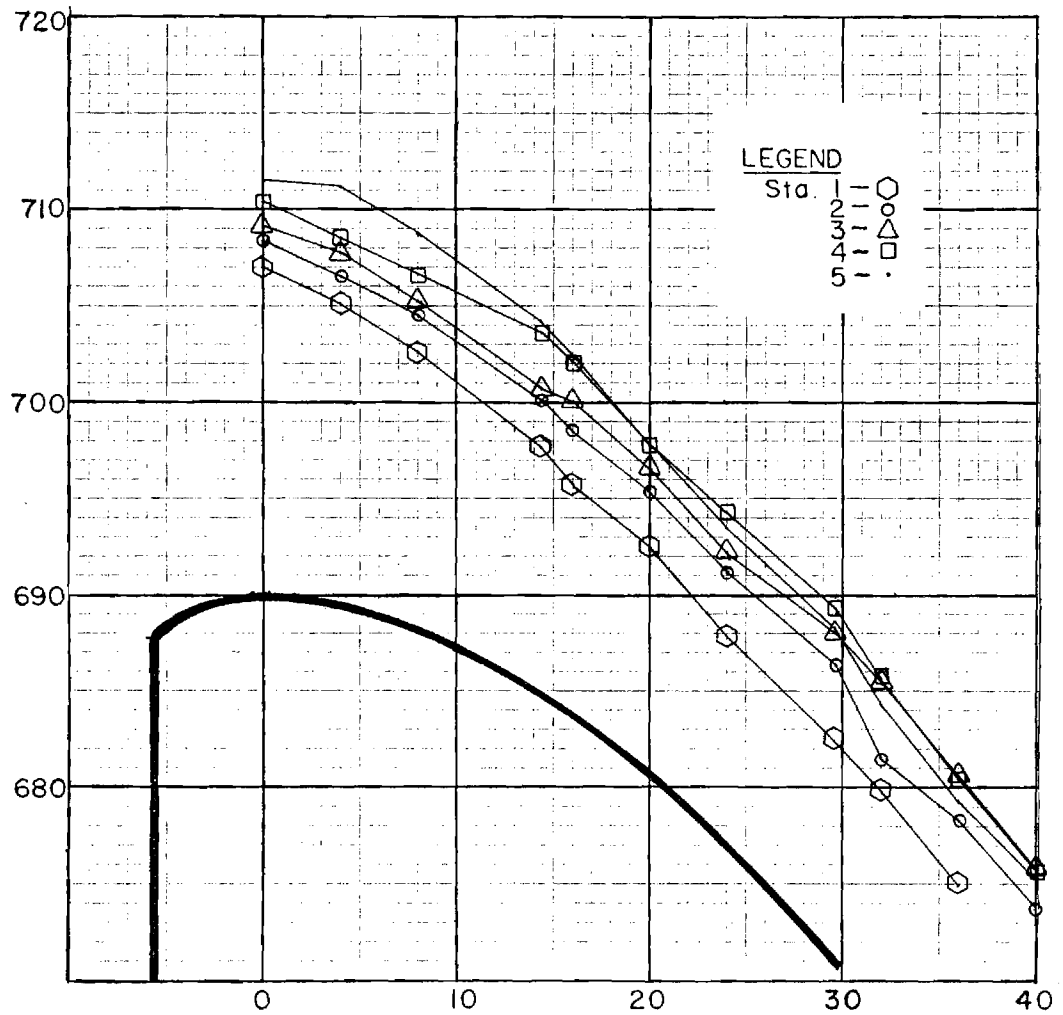

FIGURE 72.
 ROCKY MOUNTAIN PROJECT
 MAIN SPILLWAY MODEL STUDY
 1:40 SCALE MODEL

MODEL XIII, WATER SURFACE PROFILE

BAY NO. 1
 Q = 60,000 cfs
 Res. El. = 718.4'

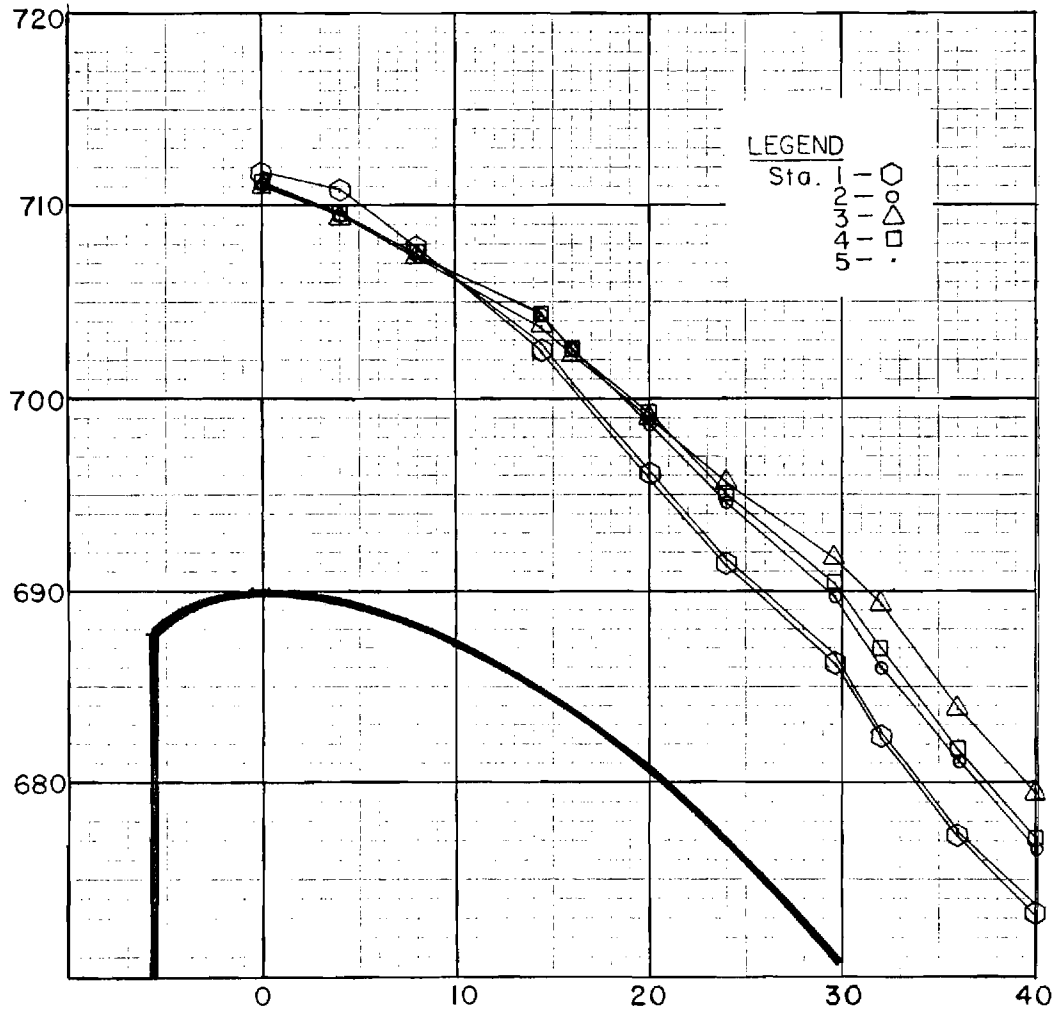

FIGURE 73.
 ROCKY MOUNTAIN PROJECT
 MAIN SPILLWAY MODEL STUDY
 1:40 SCALE MODEL

MODEL XIII, WATER SURFACE PROFILE

BAY NO. 2
 Q = 60,000 cfs
 Res. El. = 718.4'

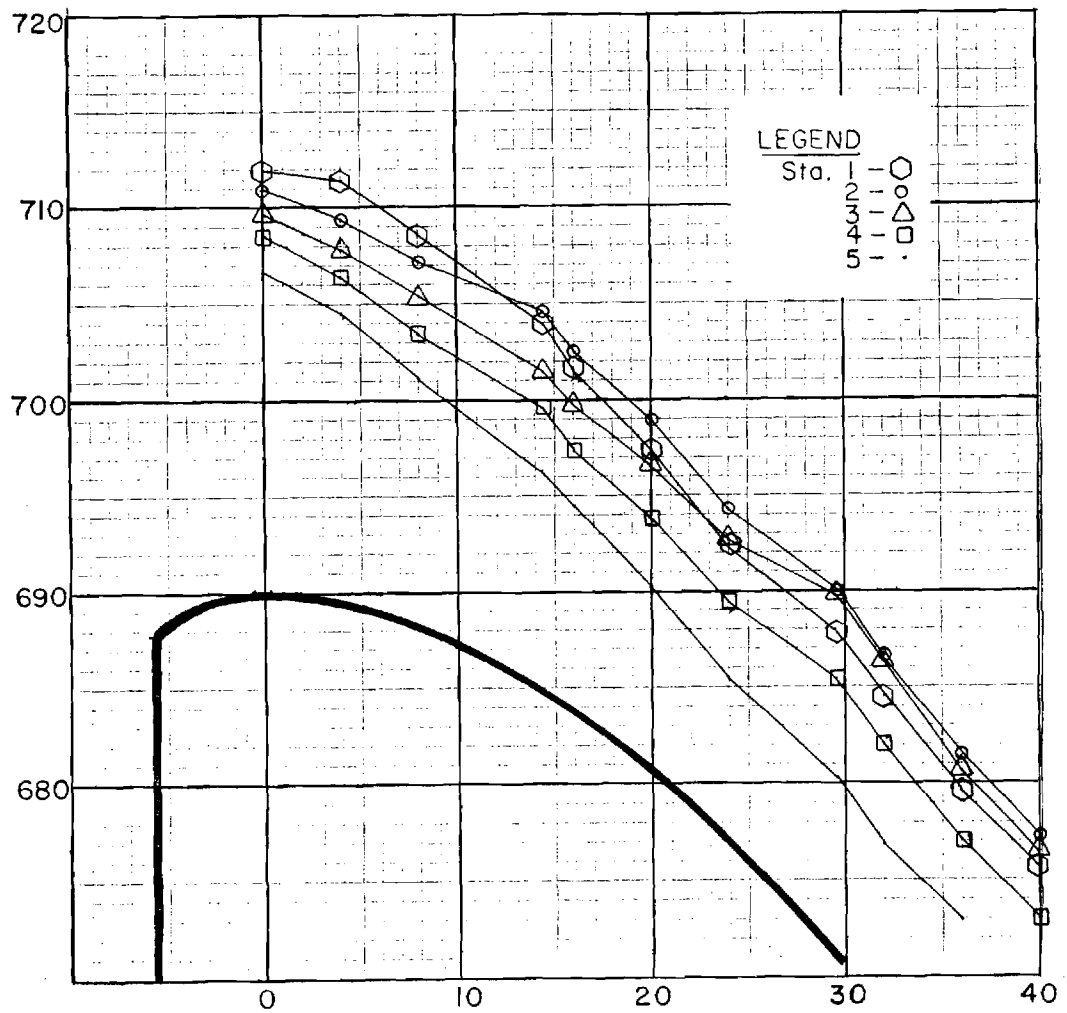

FIGURE 74.
 ROCKY MOUNTAIN PROJECT
 MAIN SPILLWAY MODEL STUDY
 1:40 SCALE MODEL

MODEL XIII, WATER SURFACE PROFILE

BAY NO. 3
 Q = 60,000 cfs
 Res. El. = 718.4'

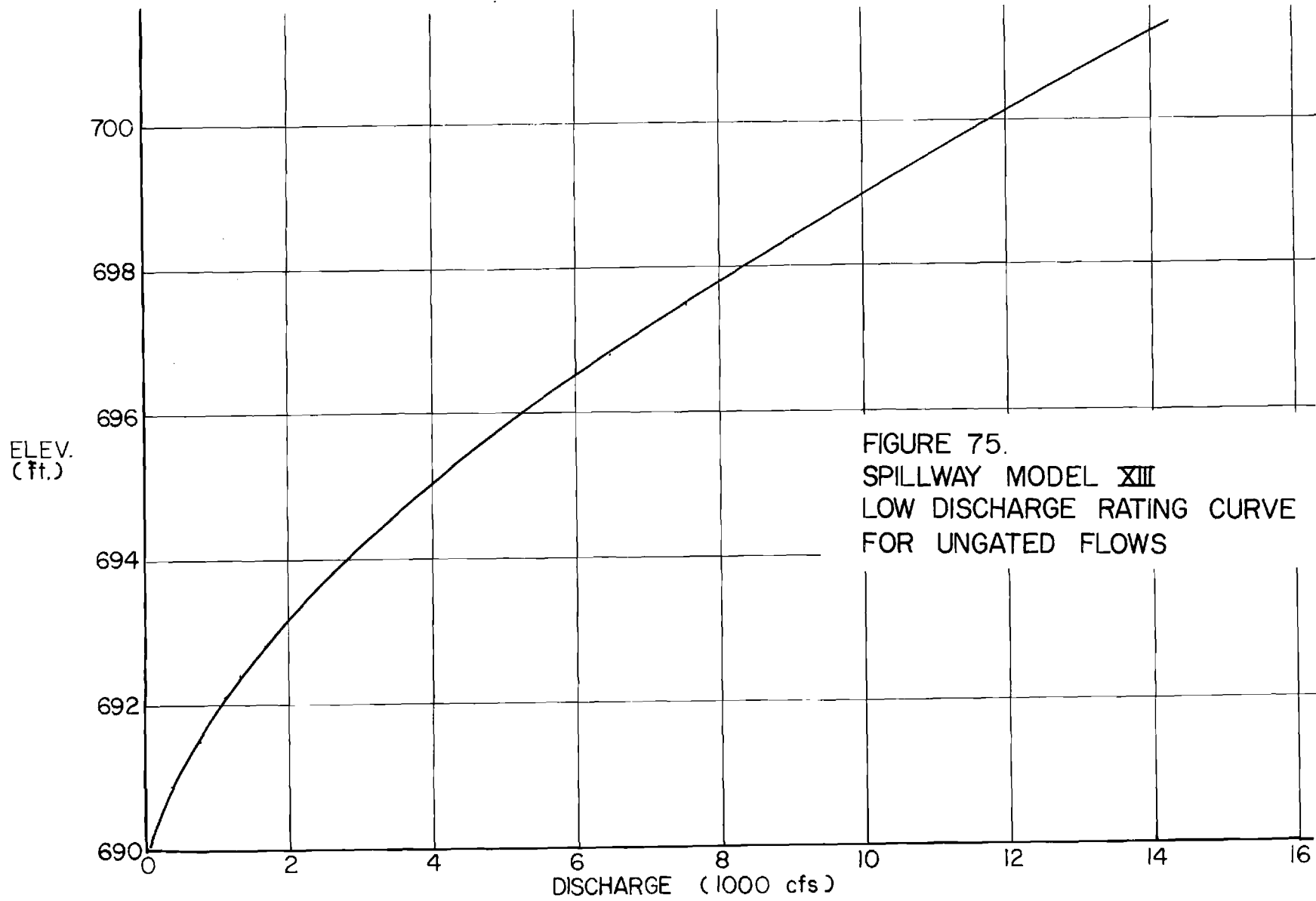

FIGURE 75.
SPILLWAY MODEL XIII
LOW DISCHARGE RATING CURVE
FOR UNGATED FLOWS

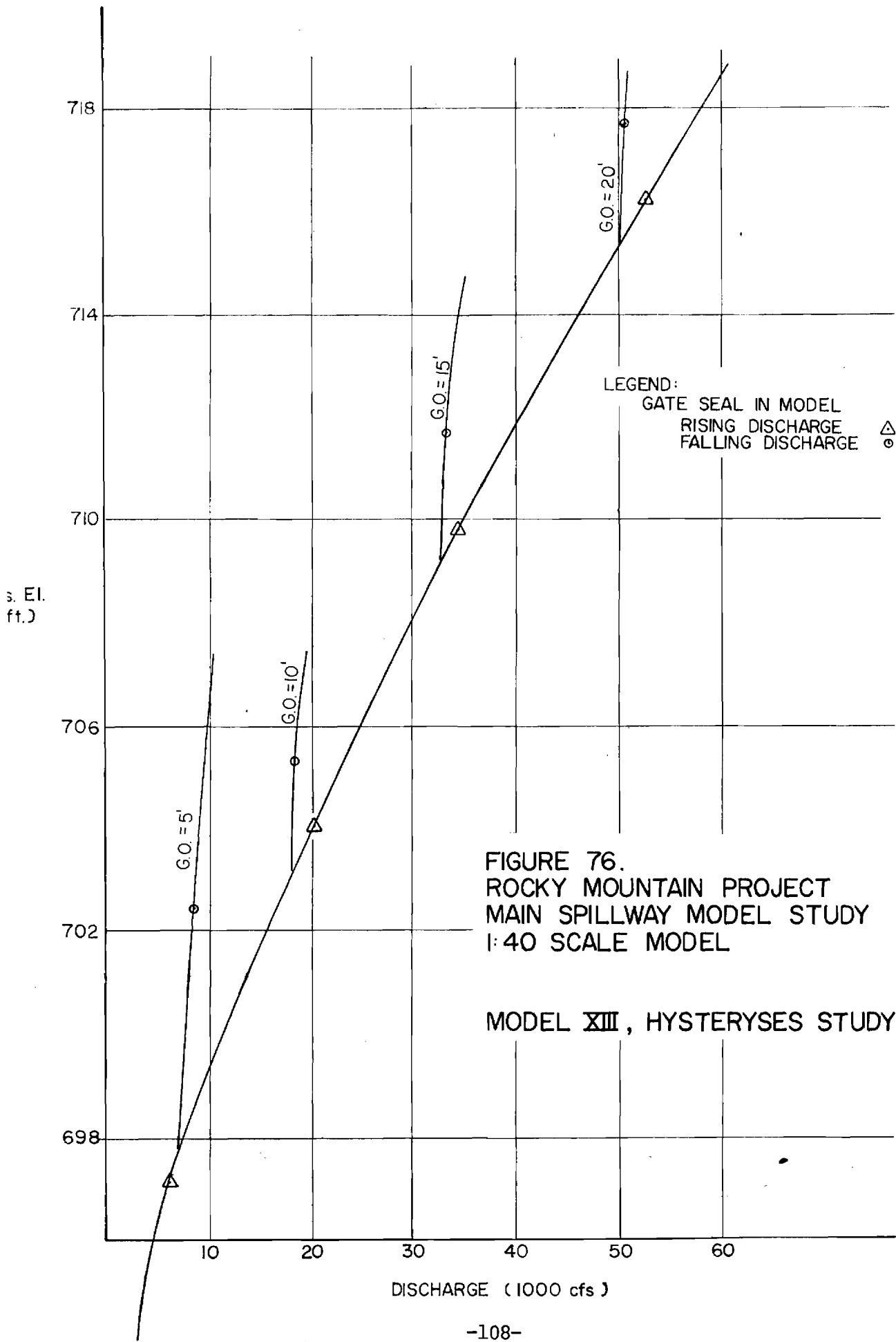

FIGURE 76.
 ROCKY MOUNTAIN PROJECT
 MAIN SPILLWAY MODEL STUDY
 1:40 SCALE MODEL

MODEL XIII, HYSTERYSES STUDY

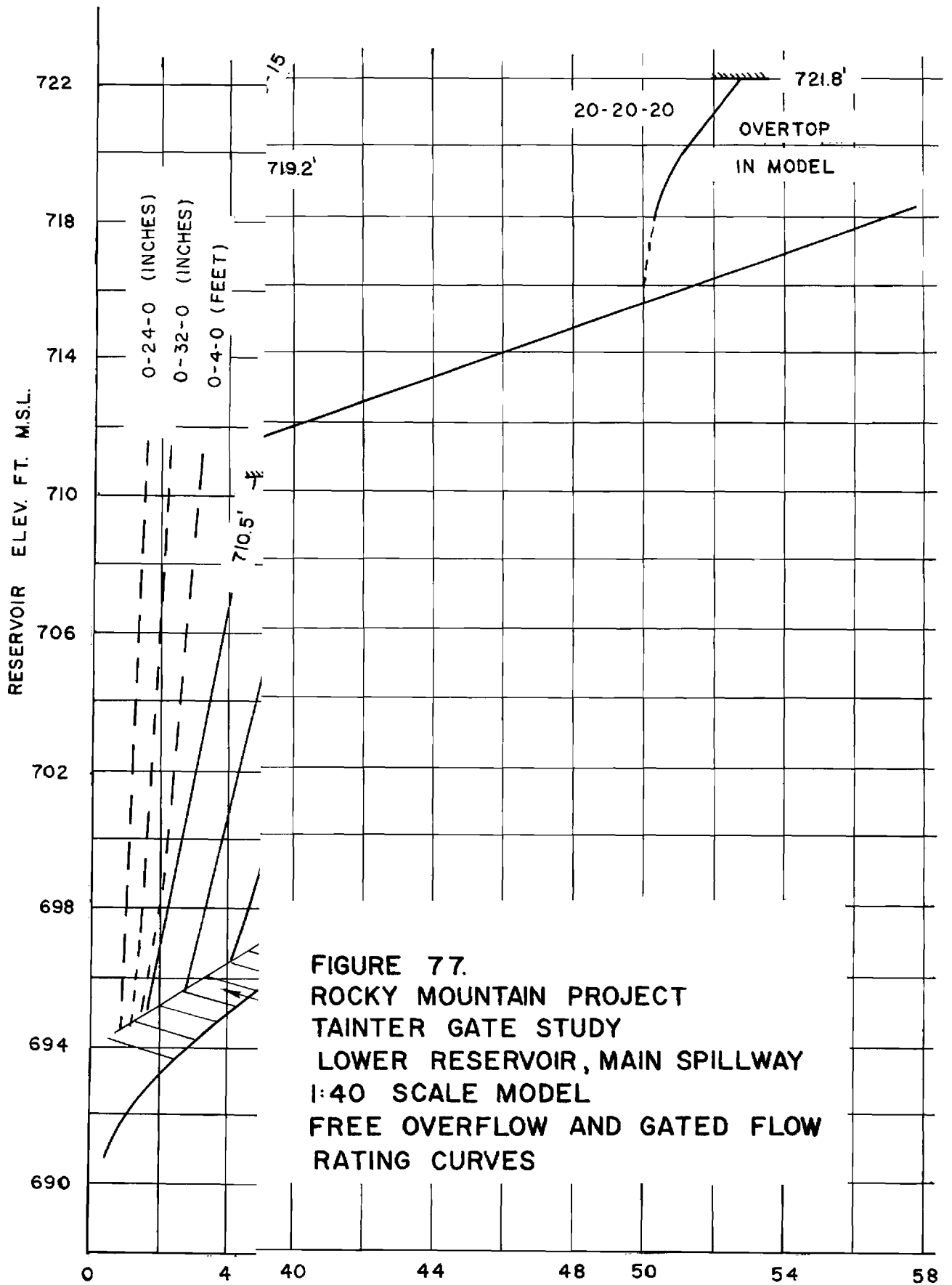

FIGURE 77.
 ROCKY MOUNTAIN PROJECT
 TAINTER GATE STUDY
 LOWER RESERVOIR, MAIN SPILLWAY
 1:40 SCALE MODEL
 FREE OVERFLOW AND GATED FLOW
 RATING CURVES

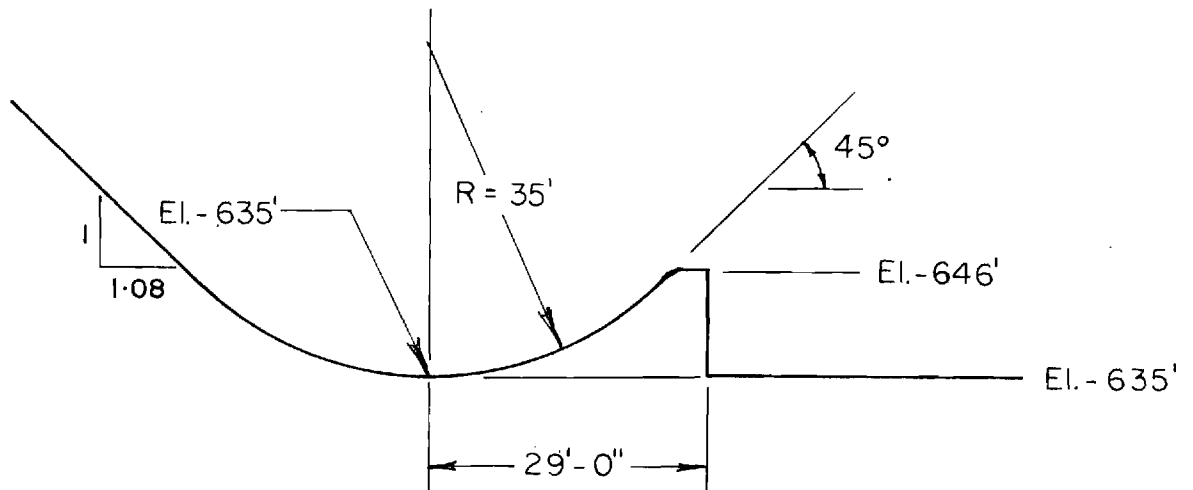

FIGURE 78.
 ROCKY MOUNTAIN PROJECT
 MAIN SPILLWAY MODEL STUDY
 1:40 SCALE MODEL

BUCKET TYPE DISSIPATOR
 45° EXIT ANGLE
 INVERT ELEV. : 635'
 EXIT LIP ELEV. : 646'

-III-

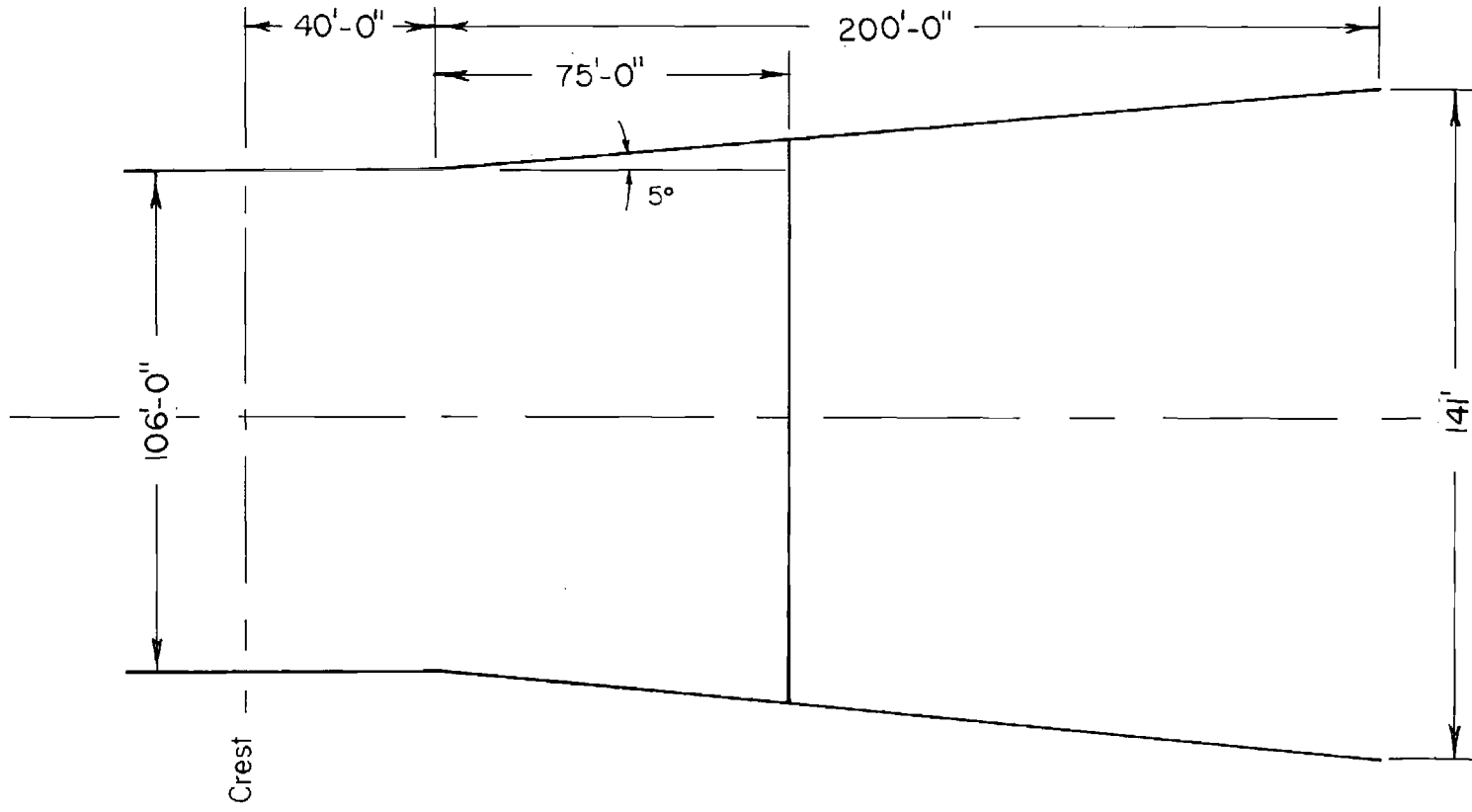

FIGURE 79.
ROCKY MOUNTAIN PROJECT
MAIN SPILLWAY MODEL STUDY
1:40 SCALE MODEL

BUCKET TYPE DISSIPATOR WINGWALLS
PLAN VIEW, 5° FLARE ANGLE

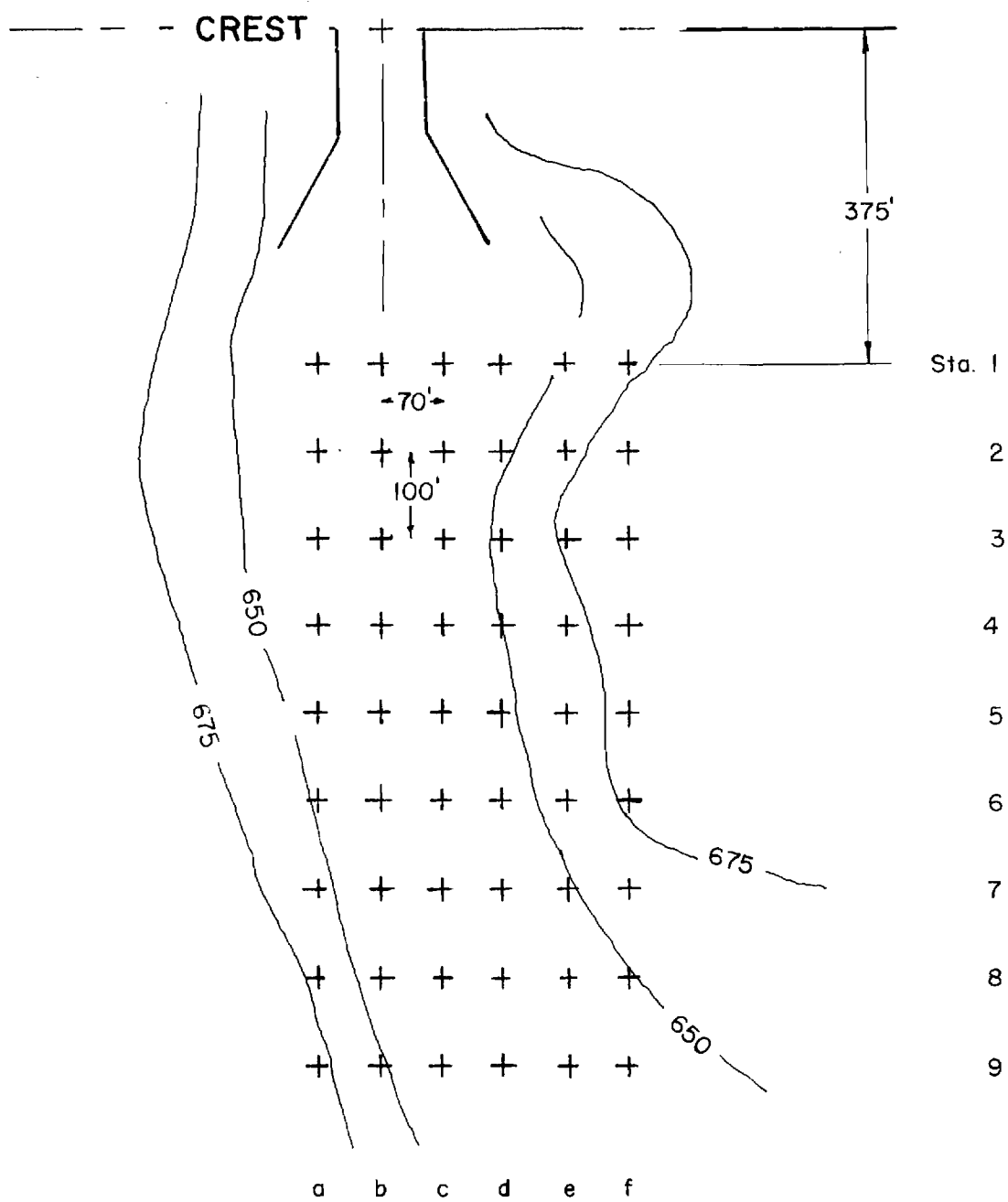

FIGURE 80.
 ROCKY MOUNTAIN PROJECT
 MAIN SPILLWAY MODEL STUDY
 1:40 SCALE MODEL

TAILRACE VELOCITY PROFILE,
 DEFINITION SKETCH

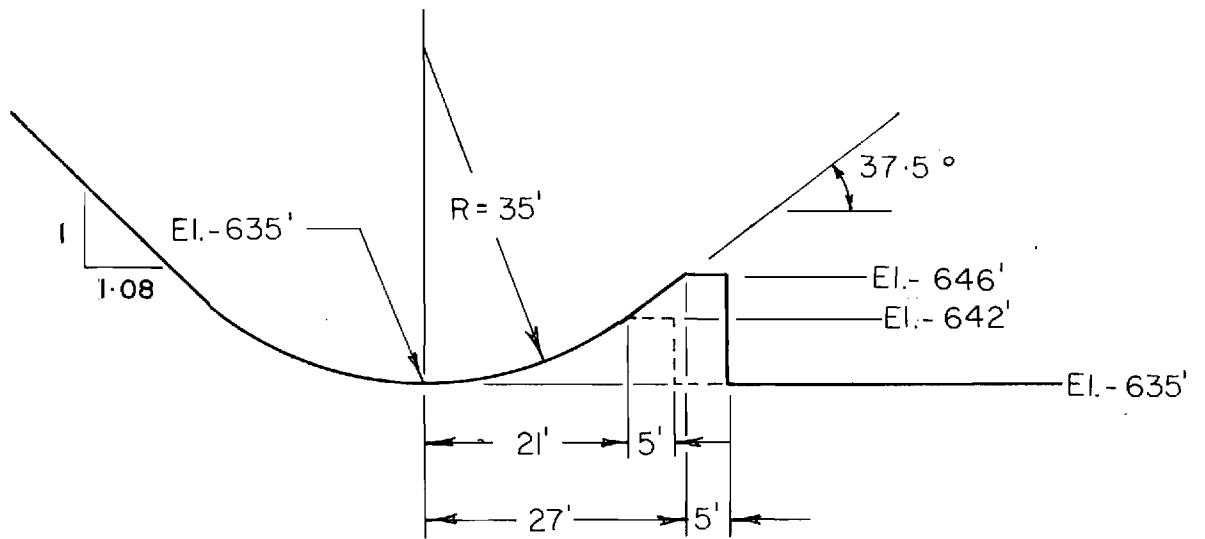

FIGURE 81.
 ROCKY MOUNTAIN PROJECT
 MAIN SPILLWAY MODEL STUDY
 1:40 SCALE MODEL

BUCKET TYPE DISSIPATOR
 37.5° EXIT ANGLE
 INVERT ELEV. : 635'
 EXIT LIP ELEV. : 642', 646'

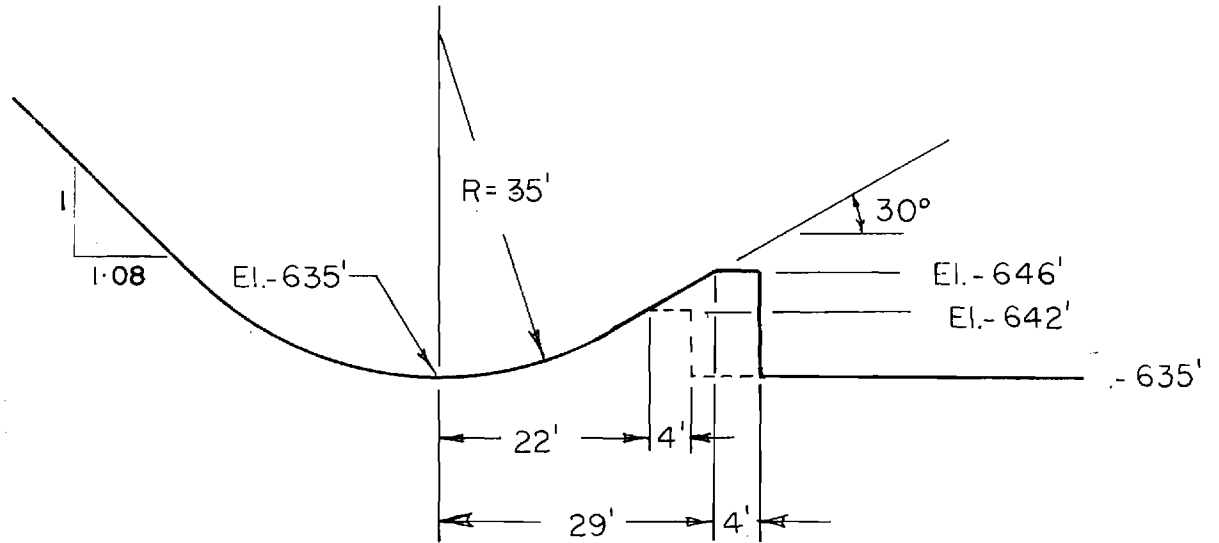

FIGURE 82.
ROCKY MOUNTAIN PROJECT
MAIN SPILLWAY MODEL STUDY
1:40 SCALE MODEL

BUCKET TYPE DISSIPATOR
30° EXIT ANGLE
INVERT ELEV. : 635'
EXIT LIP ELEVS. : 640', 642', 646'

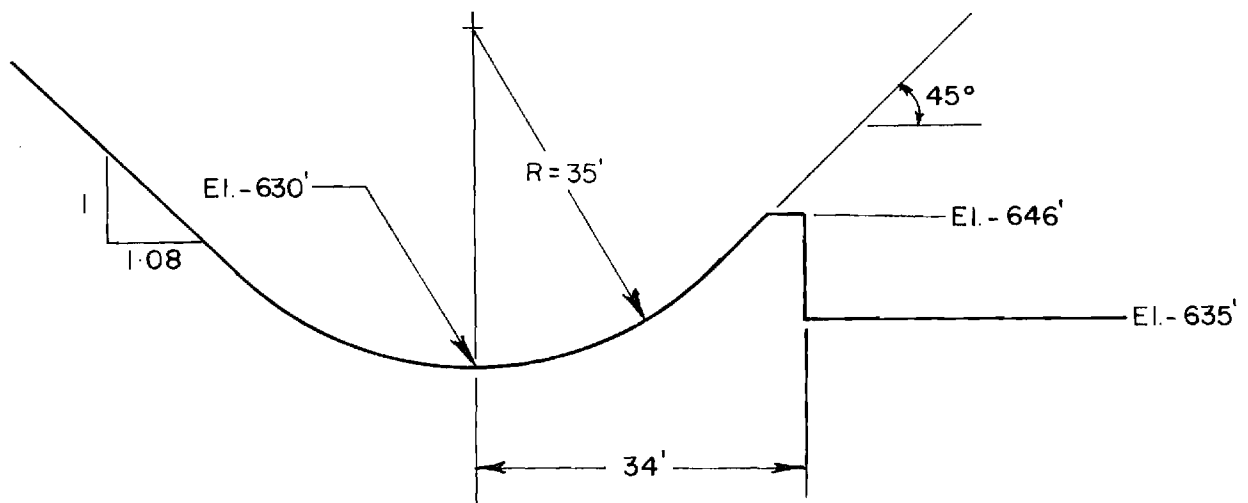

FIGURE 83.
 ROCKY MOUNTAIN PROJECT
 MAIN SPILLWAY MODEL STUDY
 1:40 SCALE MODEL

BUCKET TYPE DISSIPATOR
 45° EXIT ANGLE
 INVERT ELEV. : 630'
 EXIT LIP ELEV. : 646'

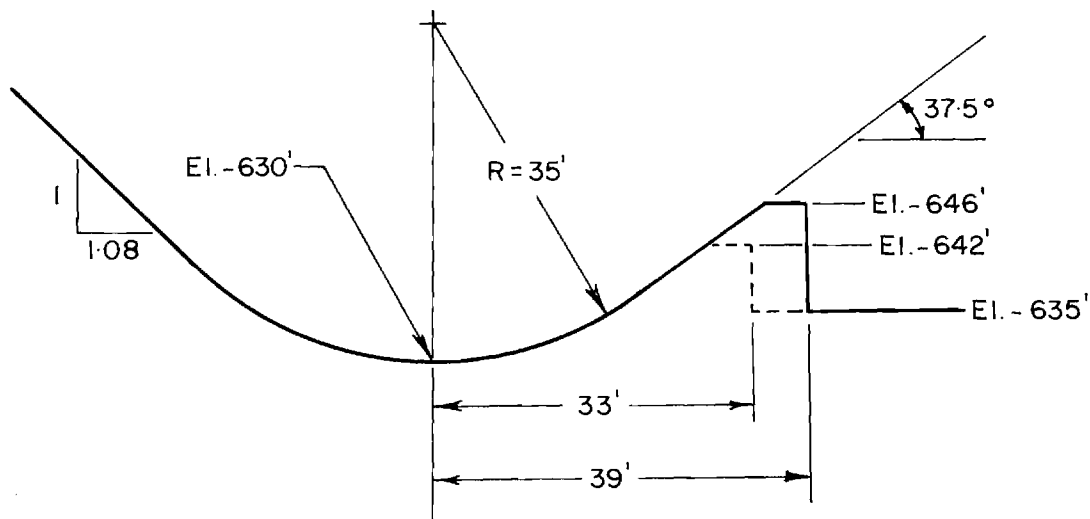

FIGURE 84.
 ROCKY MOUNTAIN PROJECT
 MAIN SPILLWAY MODEL STUDY
 1:40 SCALE MODEL

BUCKET TYPE DISSIPATOR
 37.5° EXIT ANGLE
 INVERT ELEV.: 630'
 EXIT LIP ELEV.: 642', 646'

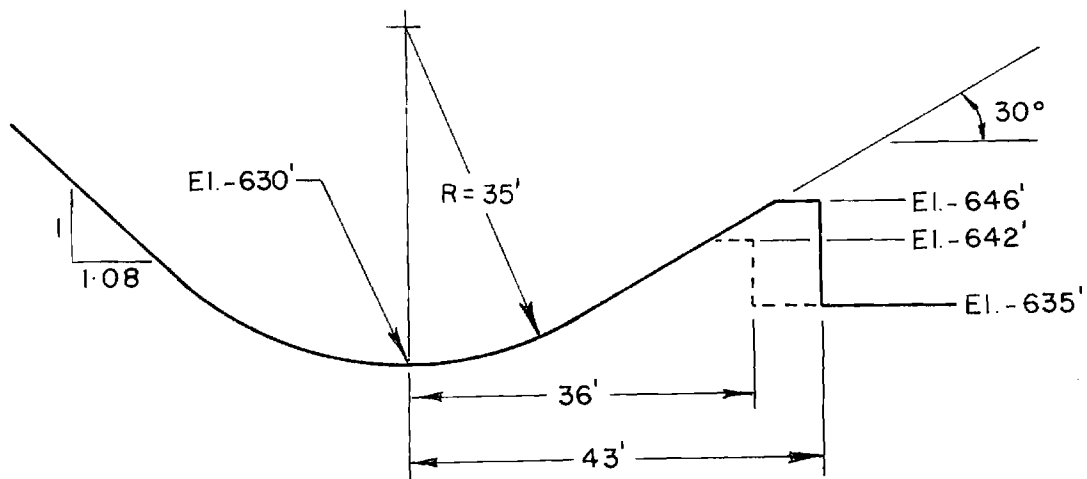

FIGURE 85.
 ROCKY MOUNTAIN PROJECT
 MAIN SPILLWAY MODEL STUDY
 1:40 SCALE MODEL

BUCKET TYPE DISSIPATOR
 30° EXIT ANGLE
 INVERT ELEV. : 630'
 EXIT LIP ELEVS. : 642', 646'

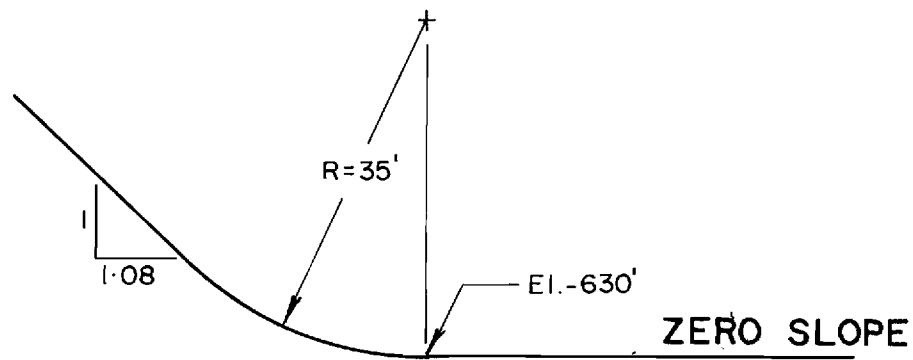

FIGURE 86.
 ROCKY MOUNTAIN PROJECT
 MAIN SPILLWAY MODEL STUDY
 1:40 SCALE MODEL

BUCKET TYPE DISSIPATOR
 0° RAMP ANGLE
 INVERT ELEV. - 630'
 EXIT LIP ELEV. - 630'

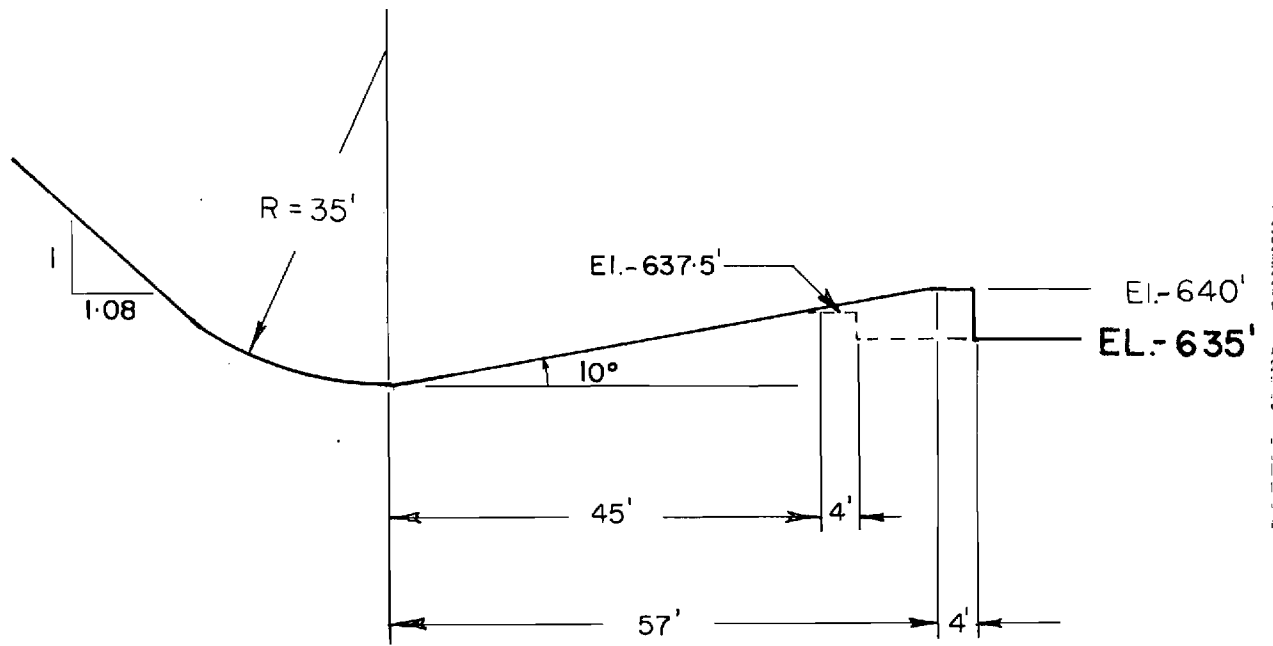

FIGURE 87.
 ROCKY MOUNTAIN PROJECT
 MAIN SPILLWAY MODEL STUDY
 1:40 SCALE MODEL

BUCKET TYPE DISSIPATOR
 10° RAMP ANGLE
 INVERT ELEV. - 630'
 EXIT LIP ELEV. - 637.5', 640'

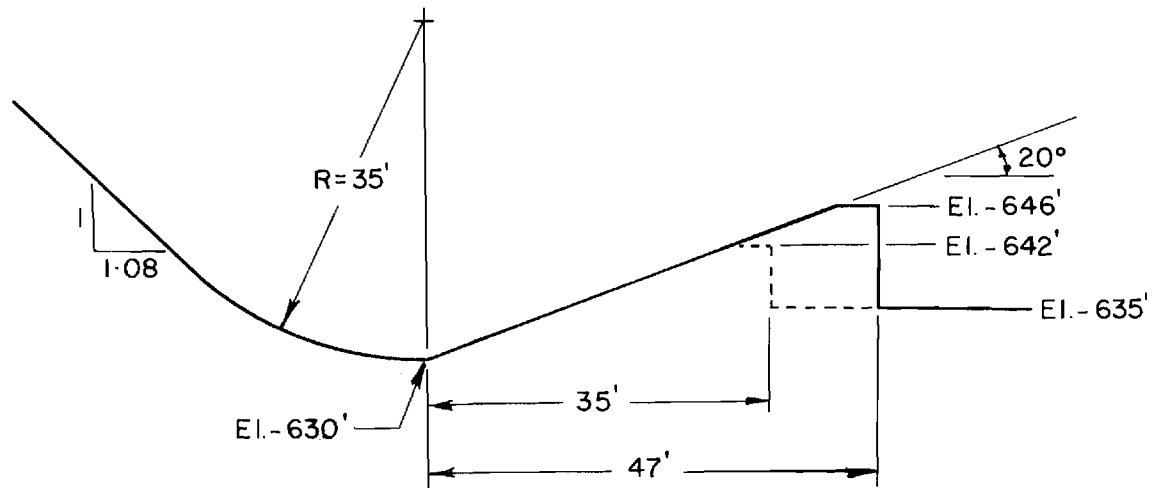

FIGURE 88.
 ROCKY MOUNTAIN PROJECT
 MAIN SPILLWAY MODEL STUDY
 1:40 SCALE MODEL

BUCKET TYPE DISSIPATOR
 20° RAMP ANGLE
 INVERT ELEV. - $630'$
 EXIT LIP ELEV. - $642', 646'$

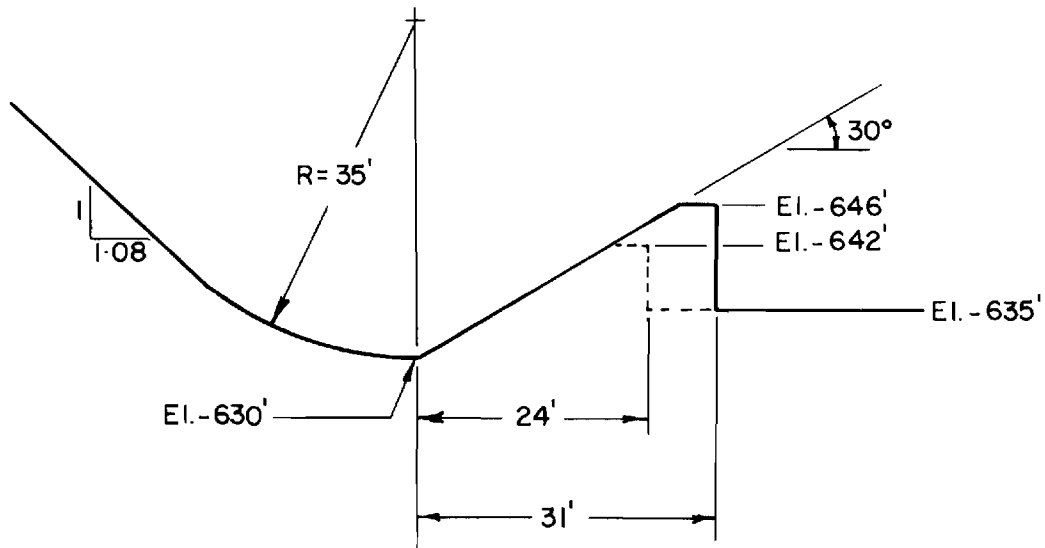

FIGURE 89.
 ROCKY MOUNTAIN PROJECT
 MAIN SPILLWAY MODEL STUDY
 1:40 SCALE MODEL

BUCKET TYPE DISSIPATOR
 30° RAMP ANGLE
 INVERT ELEV. - 630'
 EXIT LIP ELEV. - 642', 646'

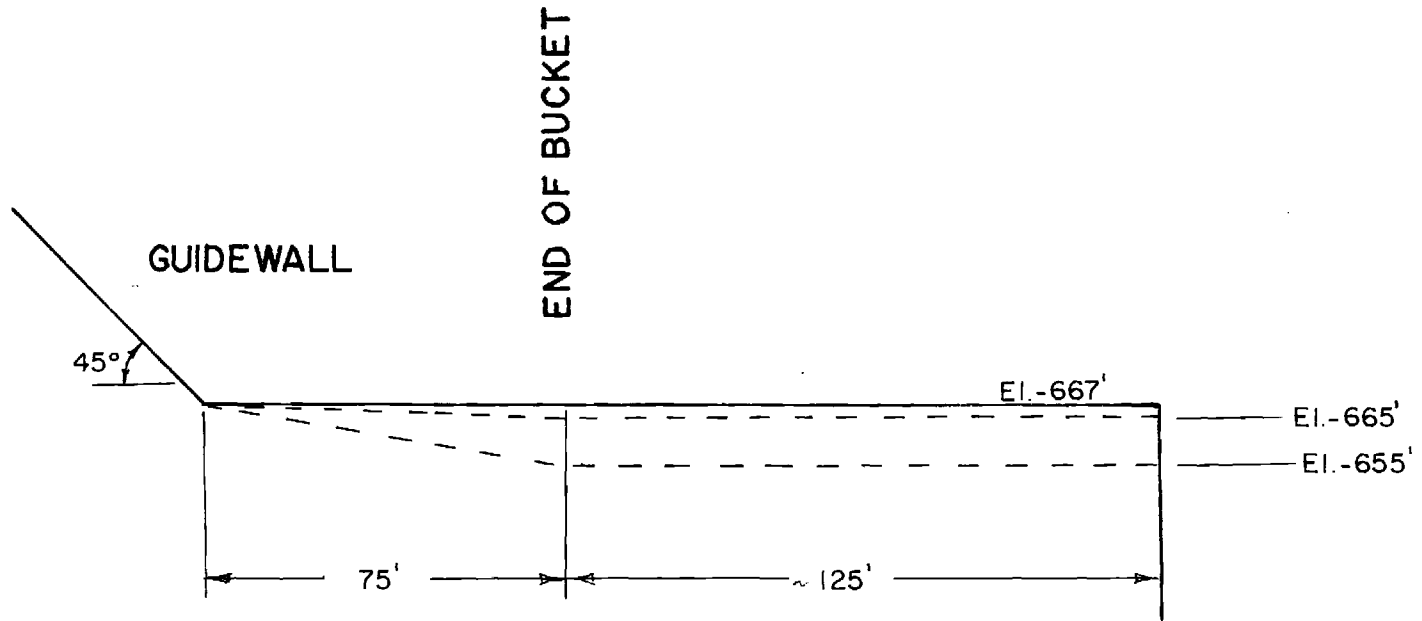

FIGURE 90.
ROCKY MOUNTAIN PROJECT
MAIN SPILLWAY MODEL STUDY
1:40 SCALE MODEL

BUCKET TYPE DISSIPATOR WINGWALLS
TYPICAL ELEVATION VIEWS

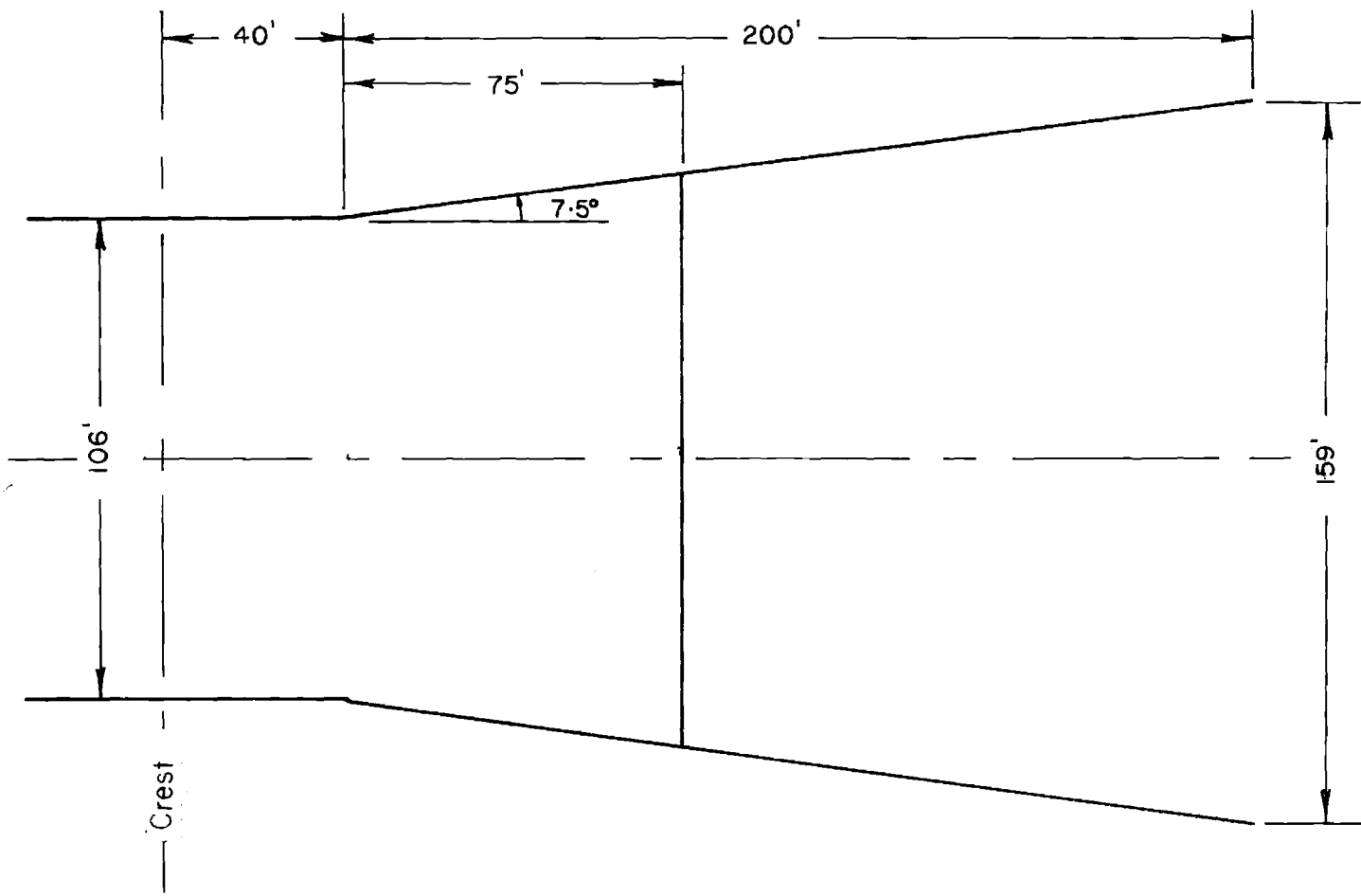

FIGURE 91.
 ROCKY MOUNTAIN PROJECT
 MAIN SPILLWAY MODEL STUDY
 1:40 SCALE MODEL

BUCKET TYPE DISSIPATOR WINGWALLS
 PLAN VIEW, 7.5° FLARE ANGLE

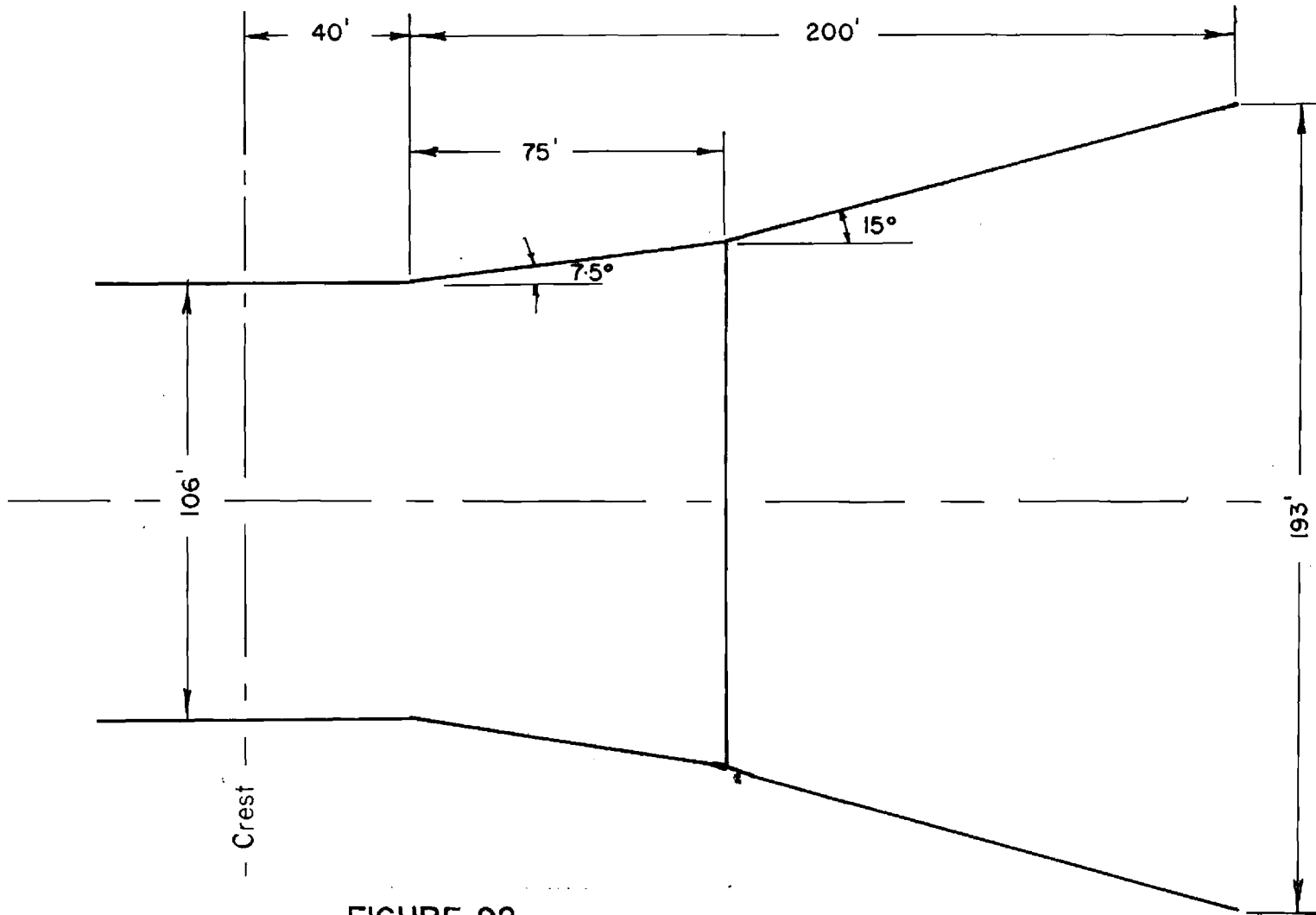

FIGURE 92.
 ROCKY MOUNTAIN PROJECT
 MAIN SPILLWAY MODEL STUDY
 1:40 SCALE MODEL

BUCKET TYPE DISSIPATOR WINGWALLS
 PLAN VIEW; 7.5°, 15° FLARE ANGLES

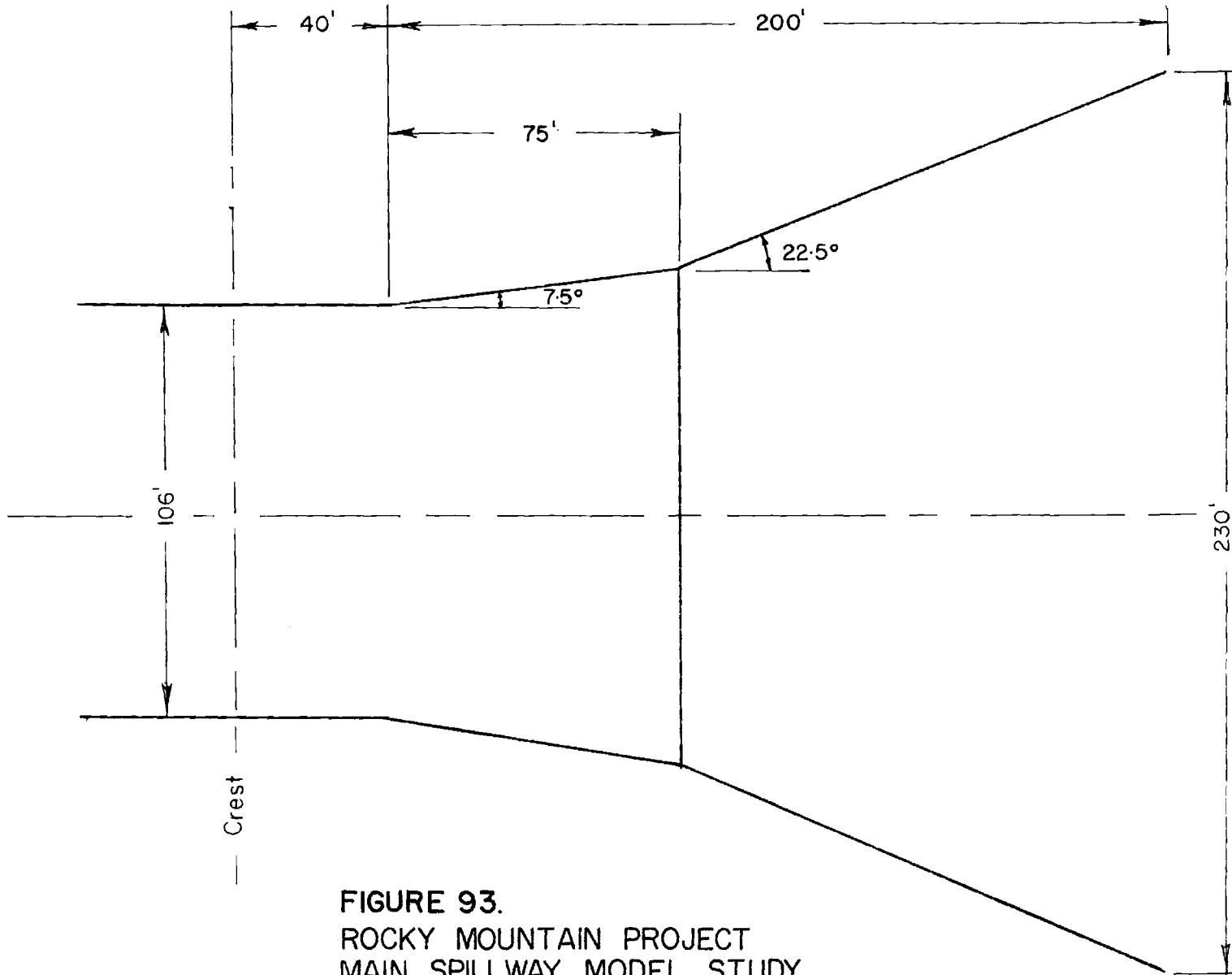

FIGURE 93.
ROCKY MOUNTAIN PROJECT
MAIN SPILLWAY MODEL STUDY
1:40 SCALE MODEL

BUCKET TYPE DISSIPATOR WINGWALLS
PLAN VIEW; 7.5°, 22.5° FLARE ANGLES

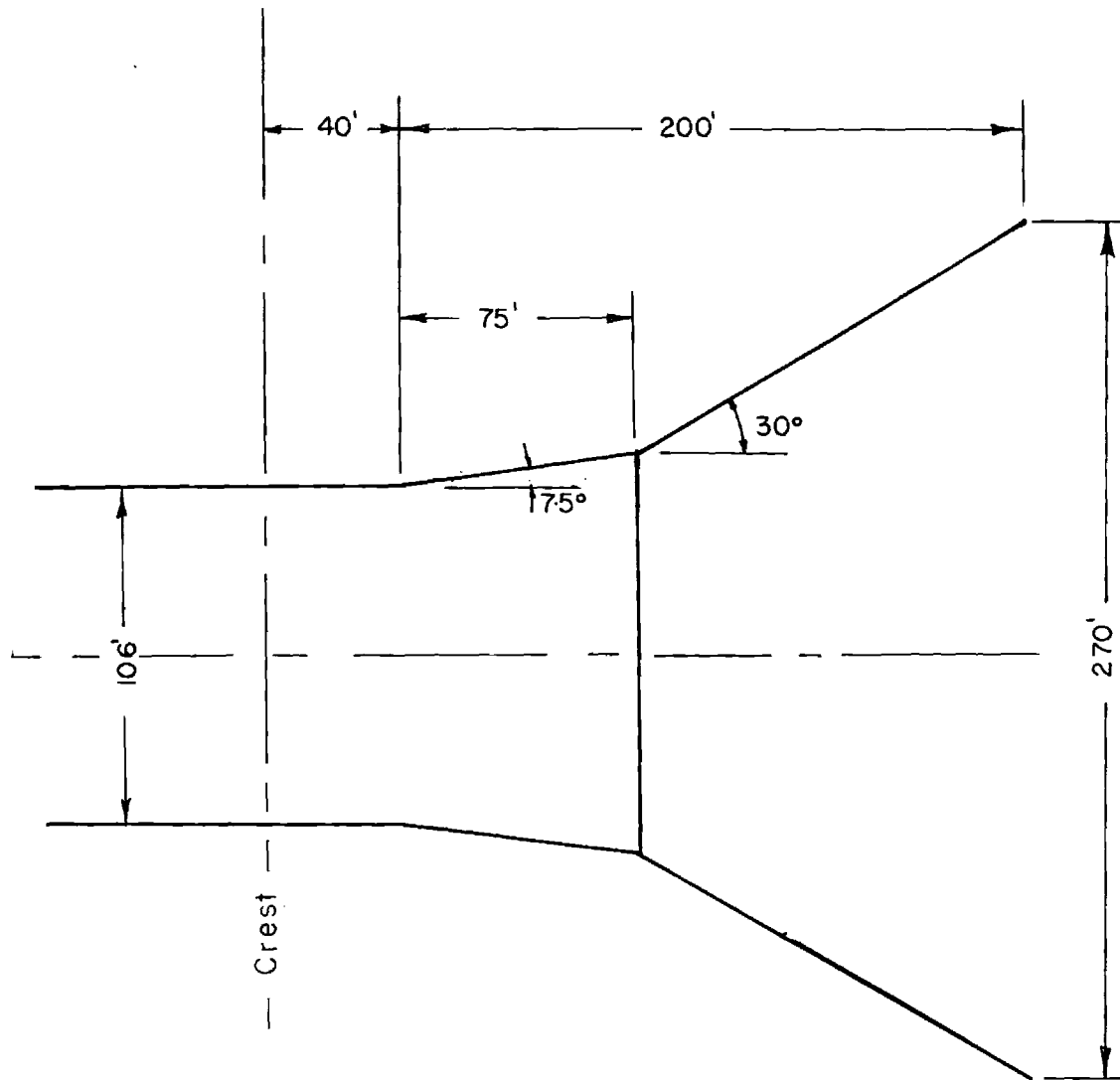

FIGURE 94.
 ROCKY MOUNTAIN PROJECT
 MAIN SPILLWAY MODEL STUDY
 1:40 SCALE MODEL

BUCKET TYPE DISSIPATOR WINGWALLS
 PLAN VIEW; 7.5°, 30° FLARE ANGLES

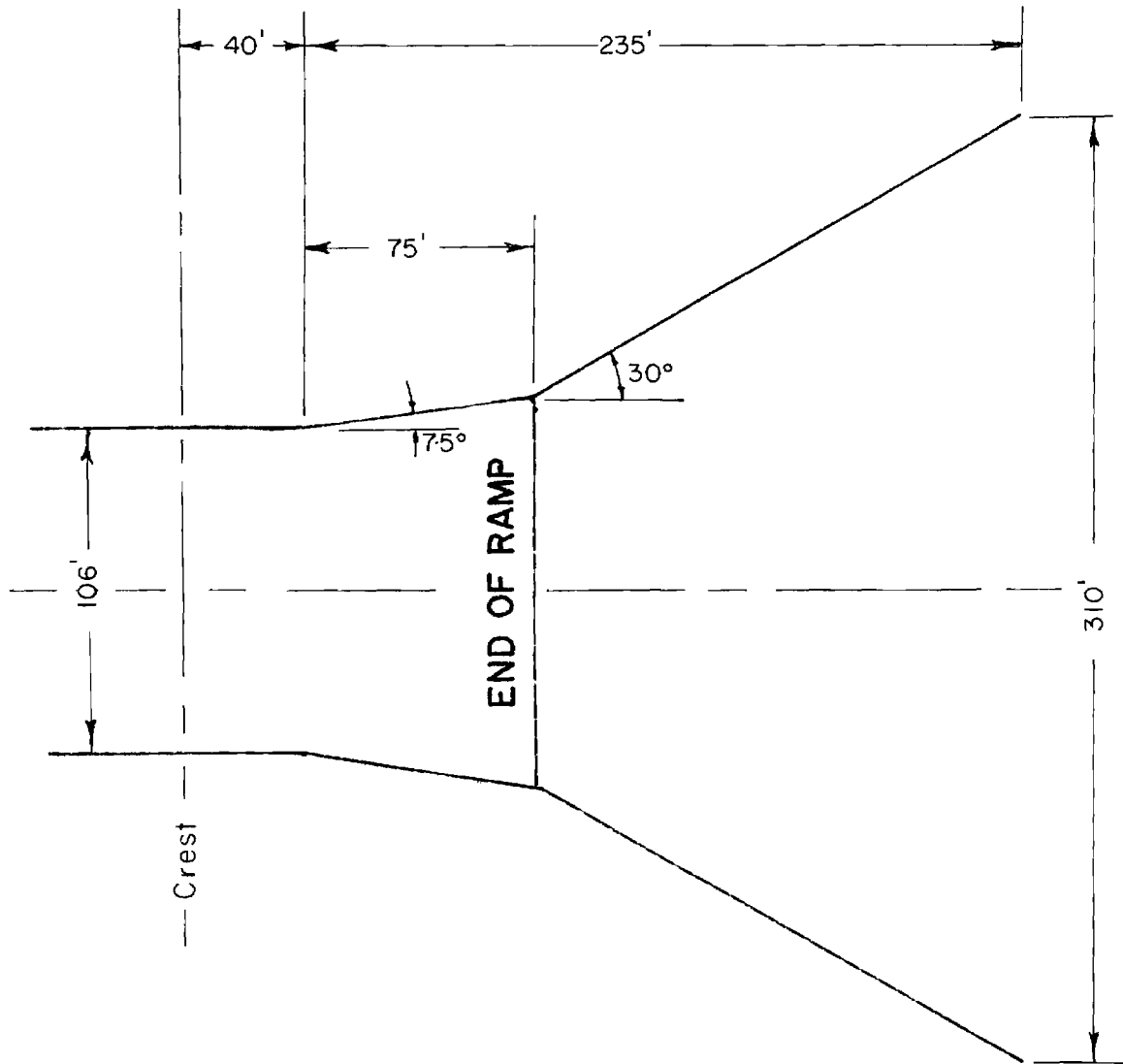

FIGURE 95.
 ROCKY MOUNTAIN PROJECT
 MAIN SPILLWAY MODEL STUDY
 1:40 SCALE MODEL

BUCKET TYPE DISSIPATOR
 EXTENDED WINGWALLS
 PLAN VIEW; 7.5°, 30° FLARE ANGLES

Movable Bed in Model

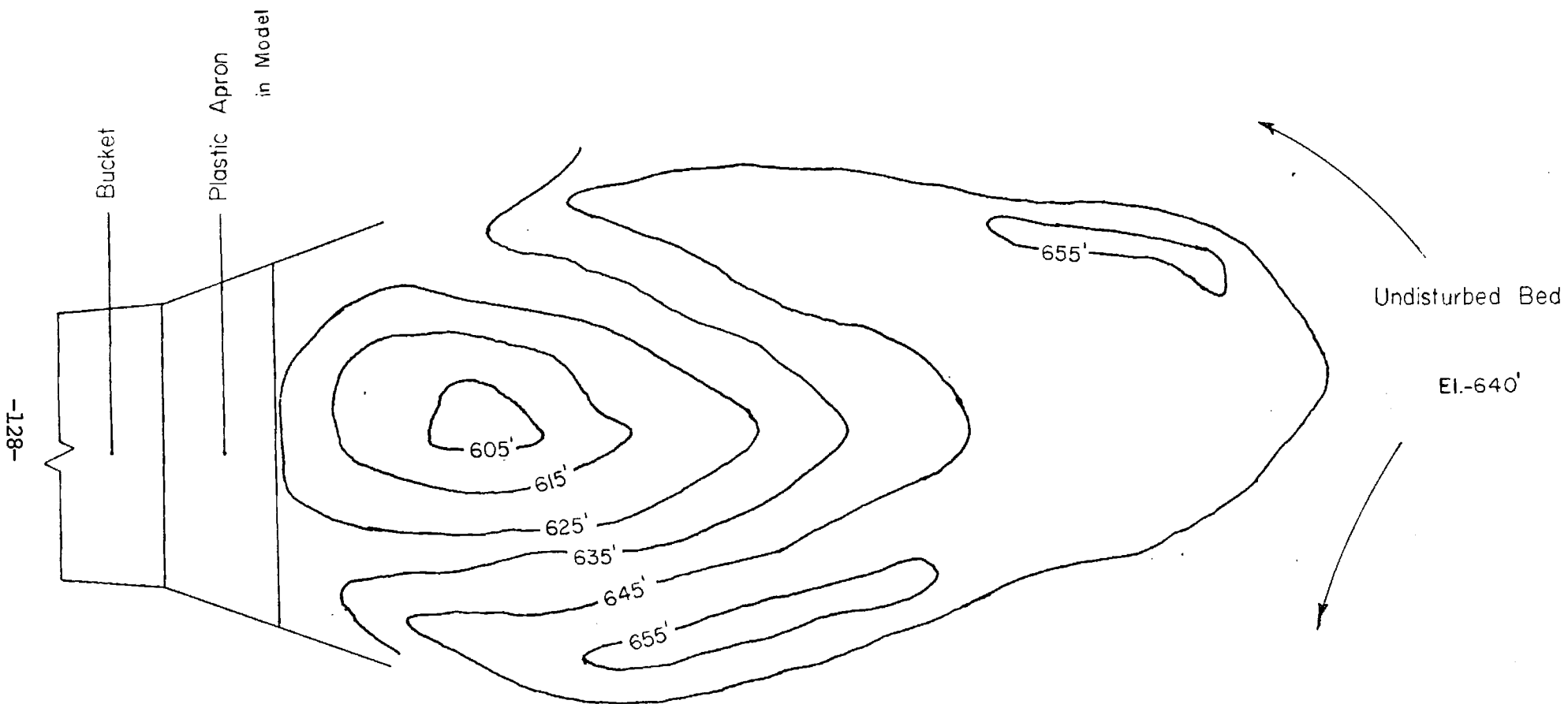

FIGURE 96.
ROCKY MOUNTAIN PROJECT
MAIN SPILLWAY MODEL STUDY
1:40 SCALE MODEL

TAILRACE SCOUR PATTERN

ROCKY MOUNTAIN PROJECT
LOWER RESERVOIR MAIN SPILLWAY
1:40 Scale Spillway Model 1

Table 1. SPILLWAY RATING, UNGATED FLOW

Head, ft	Discharge, cfs
15.1	24,800
18.0	32,280
20.8	39,950
23.2	47,050
25.6	54,310
27.7	60,730
30.3	69,040

ROCKY MOUNTAIN PROJECT
 LOWER RESERVOIR MAIN SPILLWAY
 1:40 Scale Spillway Model 1

Table 2. SPILLWAY WATER SURFACE SURVEY

Reservoir Elevation 710.8 ft.
 Flow Over Spillway 40,000 cfs

Bay Number	Distance from Crest, ft	Water Surface Elevation, ft				
		1	2	3	4	5
1	0	701.1	703.8	705.5	706.3	707.2
	4	699.8	702.3	704.0	705.1	708.4
	8	698.9	700.2	702.2	703.9	706.4
	12	696.8	698.1	700.0	702.6	702.2
	16	694.8	695.3	697.6	700.2	698.0
	20	692.0	692.3	694.4	696.7	693.7
	24	689.0	688.5	691.2	692.5	689.3
	28	685.7	684.2	687.3	687.4	684.7
	32	681.0	680.1	683.4	682.2	679.7
	36	676.8	675.0	678.6	676.8	674.5
	40	N/A	N/A	673.6	N/A	N/A
2	0	707.4	706.6	706.4	706.6	707.3
	4	708.0	705.5	705.2	705.4	708.3
	8	705.8	704.2	703.6	704.0	706.5
	12	701.5	702.9	701.9	702.9	702.1
	16	697.6	700.5	699.6	700.7	697.6
	20	694.0	697.2	697.0	697.3	693.2
	24	690.0	693.5	693.9	693.3	688.9
	28	685.2	688.5	690.3	688.6	683.6
	32	679.8	683.4	687.1	683.5	677.8
	36	675.1	678.5	683.2	677.8	N/A
	40	N/A	N/A	678.5	N/A	N/A
3	0	707.1	706.2	705.3	703.6	699.9
	4	708.8	705.1	703.8	702.0	698.9
	8	706.6	703.7	702.0	700.0	697.2
	12	701.8	702.8	699.8	697.8	695.6
	16	697.8	700.5	697.3	695.2	693.4
	20	694.1	697.1	694.5	691.8	690.8
	24	690.3	692.8	690.9	688.7	687.4
	28	686.4	687.2	687.8	684.1	684.4
	32	681.7	681.9	683.5	679.4	678.3
	36	677.2	676.7	678.8	674.4	674.4
	40	N/A	N/A	673.5	N/A	N/A

Note: Data correspond to Figure 6.

ROCKY MOUNTAIN PROJECT
 LOWER RESERVOIR MAIN SPILLWAY
 1:40 Scale Spillway Model 1

Table 3. SPILLWAY WATER SURFACE SURVEY

Reservoir Elevation 714.3 ft
 Flow Over Spillway 50,000 cfs

Bay Number	Distance from Crest, ft	Water Surface Elevation, ft				
		1	2	3	4	5
1	0	702.9	706.0	708.0	709.1	710.2
	4	701.8	704.3	706.5	708.0	711.6
	8	700.7	702.3	704.8	706.4	710.2
	12	699.1	700.3	702.7	705.8	706.0
	16	697.0	697.7	700.0	703.8	702.0
	20	694.6	694.5	697.3	700.1	697.5
	24	691.5	691.8	693.8	695.9	693.6
	28	687.7	687.8	691.4	691.7	689.2
	32	683.4	683.2	687.2	686.3	684.3
	36	679.8	678.9	682.4	681.6	677.9
2	40	675.5	674.3	675.6	676.0	672.4
	0	710.5	709.6	709.5	709.5	710.4
	4	711.5	708.6	708.3	708.7	711.6
	8	709.5	707.2	706.8	707.3	710.2
	12	705.4	706.2	705.0	706.2	705.1
	16	701.3	704.0	702.9	704.4	701.1
	20	697.2	700.8	700.4	700.7	697.2
	24	693.8	697.2	697.7	696.8	692.5
	28	689.8	693.2	695.3	692.6	688.2
	32	685.3	687.6	692.0	687.8	683.2
3	36	681.0	683.3	687.5	682.4	677.7
	40	675.0	677.5	683.8	677.2	673.4
	0	710.3	709.1	707.7	705.0	700.6
	4	712.3	708.0	706.2	703.6	699.3
	8	710.4	706.6	704.4	701.7	698.1
	12	705.4	705.9	702.4	699.5	696.0
	16	701.7	704.0	700.0	696.9	694.7
	20	697.6	700.5	697.2	694.1	691.5
	24	694.2	696.5	694.3	690.8	688.4
	28	690.4	691.4	690.8	687.2	683.9
32	686.1	686.1	687.2	682.6	679.2	
36	682.2	680.8	683.2	677.5	674.4	
40	676.2	676.0	677.9	674.8	N/A	

Note: Data correspond to Figure 6.

ROCKY MOUNTAIN PROJECT
 LOWER RESERVOIR MAIN SPILLWAY
 1:40 Scale Spillway Model 1

Table 4. SPILLWAY WATER SURFACE SURVEY

Reservoir Elevation 717.5 ft
 Flow Over Spillway 60,000 cfs

Bay Number	Distance from Crest, ft	Water Surface Elevation, ft				
		1	2	3	4	5
1	0	703.3	707.9	710.2	711.7	713.1
	4	701.9	706.0	708.8	710.6	715.3
	8	700.5	703.9	706.8	709.2	713.6
	12	698.5	701.8	704.7	707.9	709.2
	16	697.5	699.4	702.4	706.2	705.4
	20	695.2	696.6	699.7	703.7	701.3
	24	691.5	693.3	696.9	699.8	697.3
	28	687.6	690.0	693.6	695.2	692.5
	32	683.9	685.5	690.3	690.1	688.0
	36	680.2	681.0	686.2	685.4	682.8
	40	675.5	675.8	681.3	679.8	678.3
2	0	713.2	712.3	712.5	712.4	713.1
	4	714.0	711.3	711.1	711.4	714.6
	8	712.8	709.9	709.7	710.0	713.1
	12	708.1	708.6	707.9	709.2	708.1
	16	704.2	706.9	706.1	707.2	704.6
	20	700.6	704.2	703.8	704.0	700.4
	24	697.2	700.4	701.5	700.4	696.2
	28	692.8	696.6	698.6	695.9	691.4
	32	689.0	692.0	695.4	691.8	687.5
	36	684.2	687.0	692.6	686.6	682.6
	40	679.4	681.8	689.2	681.7	677.0
3	0	712.9	711.7	709.9	706.4	701.9
	4	715.3	710.3	708.3	704.9	700.4
	8	713.2	709.2	706.2	703.0	698.2
	12	708.9	707.8	704.8	701.0	697.0
	16	704.6	707.1	702.4	698.6	694.5
	20	700.8	703.8	699.6	695.8	691.8
	24	697.0	699.6	696.9	692.2	688.4
	28	693.3	694.7	693.4	688.8	684.2
	32	689.4	690.1	690.8	684.4	680.1
	36	675.0	680.2	686.9	685.2	684.6
	40	680.2	679.4	681.2	675.7	N/A

Note: Data correspond to Figure 6.

ROCKY MOUNTAIN PROJECT
 LOWER RESERVOIR MAIN SPILLWAY
 1:40 Scale Spillway Model 1

Table 5. SPILLWAY WATER SURFACE SURVEY

Reservoir Elevation 717.6 ft
 Flow Over Spillway 60,700 cfs

Bay Number	Distance from Crest, ft	Water Surface Elevation, ft				
		1	2	3	4	5
1	0	704.2	708.2	711.1	712.3	713.9
	4	702.5	706.4	709.3	711.2	716.0
	8	701.7	704.5	707.2	709.9	714.5
	12	699.5	702.4	705.4	709.1	709.5
	16	697.9	699.7	701.6	707.5	706.0
	20	694.7	696.8	700.6	702.3	702.0
	24	692.2	693.8	697.6	700.6	698.0
	28	689.3	690.0	694.8	696.3	694.3
	32	685.4	687.8	691.5	691.4	690.0
	36	680.4	681.9	687.4	686.2	684.7
2	40	675.8	677.4	682.3	680.9	679.3
	0	713.8	713.2	712.9	713.0	713.8
	4	714.7	712.0	711.9	712.0	715.2
	8	713.4	710.8	710.4	710.9	714.2
	12	708.4	709.2	708.7	709.8	709.6
	16	704.9	707.9	707.0	708.1	705.3
	20	701.0	705.0	704.4	705.1	700.7
	24	698.0	701.5	702.0	701.4	697.3
	28	694.1	679.4	699.4	697.3	692.7
	32	689.7	692.9	697.4	692.4	689.0
3	36	685.3	688.2	693.4	687.9	683.8
	40	680.3	682.8	689.0	684.0	678.0
	0	713.7	712.3	710.4	707.4	702.5
	4	715.4	711.0	709.1	705.4	700.5
	8	714.0	710.0	707.2	703.6	698.8
	12	709.6	709.6	705.2	701.4	696.4
	16	705.3	707.6	702.9	698.2	694.9
	20	702.1	704.3	700.4	696.3	691.2
	24	698.2	700.8	697.4	693.5	688.5
	28	694.7	696.2	694.8	690.0	683.0
32	690.7	690.2	691.9	685.2	680.3	
36	686.1	685.5	687.8	680.5	674.9	
40	681.4	680.2	682.5	676.6	N/A	

Note: Data correspond to Figure 6.

ROCKY MOUNTAIN PROJECT
 LOWER RESERVOIR MAIN SPILLWAY
 1:40 Scale Spillway Model 1

Table 6. SPILLWAY WATER SURFACE SURVEY

Reservoir Elevation 720.0 ft
 Flow Over Spillway 69,000 cfs

Bay Number	Distance from Crest, ft	Water Surface Elevation, ft				
		1	2	3	4	5
1	0	705.2	709.8	712.5	714.1	715.5
	4	703.3	707.6	710.8	712.9	715.8
	8	702.5	705.6	709.0	711.4	716.8
	12	700.7	703.0	707.0	709.8	713.1
	16	698.8	700.7	704.3	709.1	709.1
	20	696.8	698.2	701.8	706.8	704.9
	24	692.4	695.1	699.0	703.0	701.2
	28	689.5	691.8	696.0	699.0	696.8
	32	684.8	687.9	692.5	694.7	692.2
	36	681.4	683.5	689.7	690.0	687.6
	40	N/A	681.5	685.1	683.9	682.8
2	0	715.8	715.1	714.7	715.0	715.8
	4	718.0	714.0	713.6	713.9	715.7
	8	715.4	712.8	712.4	712.8	717.0
	12	712.2	711.5	710.9	711.6	712.4
	16	706.6	710.1	709.1	710.2	708.0
	20	703.7	707.3	706.9	707.5	704.4
	24	700.7	703.4	704.4	704.0	700.2
	28	696.4	699.8	702.0	700.3	696.0
	32	692.3	695.1	699.5	695.8	691.4
	36	688.7	691.8	696.2	691.7	687.0
	40	683.4	696.5	693.0	691.0	682.2
3	0	715.6	714.3	712.4	708.9	704.0
	4	717.7	713.2	710.7	706.9	702.1
	8	715.6	711.9	708.8	705.0	700.1
	12	712.6	711.7	707.2	702.8	697.8
	16	707.9	709.7	705.0	700.5	695.4
	20	703.8	706.6	702.5	698.1	692.8
	24	700.5	702.8	700.1	694.8	689.4
	28	697.0	697.7	698.0	691.4	685.4
	32	692.8	693.7	694.7	687.6	680.6
	36	688.9	688.1	689.6	683.0	N/A
	40	683.7	683.3	683.3	678.6	N/A

Note: Data correspond to Figure 6.

ROCKY MOUNTAIN PROJECT
LOWER RESERVOIR MAIN SPILLWAY
1:40 Scale Spillway Model II

Table 7. SPILLWAY RATING, UNGATED FLOW

Head, ft	Discharge, cfs
14.4	20,160
20.6	36,330
23.4	44,070
25.8	51,200
27.7	57,010
29.4	62,740
30.7	66,850

ROCKY MOUNTAIN PROJECT
 LOWER RESERVOIR MAIN SPILLWAY
 1:40 Scale Spillway Model II

Table 8. SPILLWAY WATER SURFACE SURVEY

Reservoir Elevation 710.8 ft
 Flow Over Spillway 36,400 cfs

Bay Number	Distance from Crest, ft.	Water Surface Elevation, ft				
		1	2	3	4	5
1	0	700.5	704.1	705.6	706.5	708.8
	4	699.4	702.4	704.1	706.0	707.4
	8	698.3	700.5	702.4	704.4	703.8
	12	697.0	698.1	700.4	701.8	699.7
	16	694.6	695.5	698.1	698.3	695.8
	20	692.0	692.3	695.1	694.3	691.8
	24	689.0	688.8	691.7	690.7	688.0
	28	685.2	684.6	687.5	685.5	683.8
	32	681.1	679.8	682.7	680.6	678.8
	36	676.9	675.3	677.4	675.1	N/A
	40	N/A	N/A	N/A	N/A	N/A
2	0	708.8	706.8	706.5	706.7	708.8
	4	707.4	706.3	705.3	706.2	707.6
	8	703.4	704.7	703.8	704.6	703.7
	12	699.5	702.2	702.0	701.9	699.6
	16	696.1	698.8	699.8	698.7	695.6
	20	692.2	695.3	697.6	695.6	691.7
	24	689.0	691.6	695.0	691.4	687.3
	28	684.7	687.0	691.4	686.7	683.1
	32	679.5	681.9	686.9	681.8	678.0
	36	674.3	676.8	681.6	676.4	N/A
	40	N/A	N/A	675.8	N/A	N/A
3	0	708.9	706.5	705.4	703.6	700.3
	4	707.6	706.0	703.9	698.0	698.8
	8	703.7	704.2	702.2	700.2	697.5
	12	699.9	701.5	700.2	697.9	696.0
	16	696.8	698.1	698.2	695.3	693.8
	20	693.3	694.4	695.4	692.1	691.4
	24	689.4	690.3	691.4	688.6	687.9
	28	685.4	685.7	687.0	684.5	684.2
	32	680.8	680.8	678.6	679.8	680.0
	36	675.2	675.3	676.7	675.3	675.7
	40	N/A	N/A	N/A	N/A	N/A

Note: Data correspond to Figure 6.

ROCKY MOUNTAIN PROJECT
 LOWER RESERVOIR MAIN SPILLWAY
 1:40 Scale Spillway Model II

Table 9. SPILLWAY WATER SURFACE SURVEY

Reservoir Elevation 714.3 ft
 Flow Over Spillway 47,000 cfs

Bay Number	Distance from Crest, ft	Water Surface Elevation, ft				
		1	2	3	4	5
1	0	703.6	705.8	708.4	709.4	712.0
	4	701.7	704.7	706.9	708.8	711.4
	8	700.4	702.7	705.0	707.5	707.6
	12	698.4	700.3	703.1	705.0	703.6
	16	697.6	698.0	700.6	701.4	699.6
	20	694.1	695.3	698.3	698.7	696.5
	24	691.1	691.6	695.0	694.1	692.1
	28	687.2	687.2	691.3	690.2	687.8
	32	683.2	683.0	686.8	684.6	683.9
	36	678.7	678.4	681.6	679.4	678.8
	40	674.6	674.6	675.6	674.2	N/A
2	0	712.0	710.0	709.6	709.9	711.9
	4	711.0	709.5	708.5	709.3	711.1
	8	707.2	707.9	707.0	707.9	707.4
	12	703.3	705.4	705.3	705.2	702.9
	16	699.7	702.3	703.5	702.6	699.6
	20	696.2	698.9	701.9	699.1	695.7
	24	692.8	695.4	699.3	695.4	692.0
	28	688.7	690.9	695.6	691.4	687.9
	32	684.6	686.5	691.4	686.4	683.5
	36	680.0	681.8	686.5	681.3	679.4
	40	675.0	675.9	681.3	676.1	672.8
3	0	711.9	709.4	708.1	705.5	701.3
	4	711.2	708.9	706.5	703.8	699.9
	8	707.7	707.5	704.8	702.2	698.1
	12	703.6	704.7	702.7	699.6	696.4
	16	700.2	701.8	700.3	697.2	694.9
	20	697.4	698.3	698.3	694.2	692.4
	24	693.6	694.4	694.8	690.7	688.2
	28	690.0	689.6	686.4	686.6	685.7
	32	684.9	684.8	686.2	682.2	680.3
	34	680.2	679.4	680.0	677.9	676.0
	40	673.6	674.4	675.7	N/A	N/A

Note: Data correspond to Figure 6.

ROCKY MOUNTAIN PROJECT
 LOWER RESERVOIR MAIN SPILLWAY
 1:40 Scale Spillway Model II

Table 10. SPILLWAY WATER SURFACE SURVEY

Reservoir Elevation 717.6 ft
 Flow Over Spillway 57,100 cfs

Bay Number	Distance from Crest, ft	Water Surface Elevation, ft				
		1	2	3	4	5
1	0	704.6	708.3	710.8	712.2	715.0
	4	702.3	706.6	709.2	711.8	714.7
	8	701.1	704.5	707.4	710.5	711.1
	12	699.6	702.6	705.5	708.2	707.4
	16	698.0	700.0	703.0	705.2	703.3
	20	695.5	696.9	701.3	701.8	698.0
	24	692.8	694.0	698.4	698.2	696.4
	28	689.5	690.2	694.4	693.5	691.8
	32	685.5	686.0	690.1	688.6	687.9
	36	681.4	682.0	685.3	684.0	683.1
2	40	685.4	678.1	679.4	678.4	678.4
	0	715.0	712.8	712.4	712.6	714.9
	4	714.6	712.5	711.3	712.4	714.6
	8	710.6	711.0	710.0	710.9	710.7
	12	706.8	708.7	708.4	708.8	706.6
	16	703.1	705.7	706.5	705.8	703.0
	20	699.8	702.5	705.4	702.8	699.4
	24	696.6	699.3	702.0	699.4	696.1
	28	693.2	695.2	699.3	695.0	691.7
	32	689.1	690.8	695.6	691.3	687.0
3	36	684.4	686.1	690.3	686.4	683.0
	40	680.0	680.9	685.3	681.0	676.9
	0	715.0	712.0	710.3	707.2	702.4
	4	714.7	711.7	708.8	705.3	700.6
	8	710.8	710.5	706.8	703.2	698.7
	12	707.0	708.2	705.1	701.3	696.9
	16	703.4	705.3	702.7	698.8	695.0
	20	700.5	702.0	701.0	695.9	692.2
	24	697.6	698.5	698.2	292.8	689.0
	28	693.1	693.6	694.3	688.9	685.2
3	32	689.4	688.8	690.1	685.0	681.1
	36	684.4	683.8	684.3	680.4	N/A
	40	679.4	678.7	679.0	N/A	N/A

Note: Data correspond to Figure 6.

ROCKY MOUNTAIN PROJECT
 LOWER RESERVOIR MAIN SPILLWAY
 1:40 Scale Spillway Model II

Table 11. SPILLWAY WATER SURFACE SURVEY

Reservoir Elevation 720.4 ft
 Flow Over Spillway 66,500 cfs

Bay Number	Distance from Crest, ft	Water Surface Elevation, ft				
		1	2	3	4	5
1	0	707.0	710.2	712.8	714.3	717.7
	4	705.3	708.3	711.1	713.9	717.4
	8	704.0	705.8	709.3	712.6	714.2
	12	700.5	703.9	707.3	710.7	710.3
	16	699.2	701.8	704.9	707.8	706.2
	20	698.1	699.0	703.0	704.4	702.3
	24	694.4	696.1	700.1	700.7	699.4
	28	692.3	692.6	697.2	697.2	695.4
	32	686.6	688.8	692.9	692.1	691.6
	36	681.6	684.3	688.7	687.4	686.5
2	40	677.8	679.1	682.0	682.0	681.5
	0	717.8	715.3	714.9	715.3	717.9
	4	717.2	714.8	714.0	714.7	717.5
	8	713.6	713.6	712.5	713.7	713.8
	12	709.7	711.4	710.9	711.3	709.5
	16	706.1	708.4	709.7	708.1	705.7
	20	703.1	705.2	708.3	705.7	701.8
	24	699.4	701.8	706.4	702.2	699.1
	28	695.8	698.4	703.0	698.5	694.8
	32	692.2	694.2	699.1	694.5	691.5
3	36	687.7	689.4	694.6	690.0	686.6
	40	684.2	685.0	689.4	685.0	682.5
	0	717.9	714.5	712.5	708.8	703.3
	4	717.2	714.0	710.7	706.4	701.4
	8	713.8	713.0	709.2	704.5	700.0
	12	710.3	710.5	706.9	702.0	697.4
	16	706.2	707.6	704.7	699.9	695.2
	20	702.9	704.5	703.0	697.1	692.2
	24	700.2	701.2	700.3	694.2	689.0
	28	696.4	696.1	696.8	690.4	685.0
3	32	692.6	692.2	692.4	686.5	680.0
	36	687.3	687.6	687.6	682.2	675.4
	40	682.9	682.0	682.3	677.5	N/A

Note: Data correspond to Figure 6.

ROCKY MOUNTAIN PROJECT
LOWER RESERVOIR MAIN SPILLWAY
1:40 Scale Spillway Model III

Table 12. SPILLWAY RATING, UNGATED FLOW

Head, ft	Discharge, cfs
14.2	20,390
15.7	24,180
20.2	35,060
23.0	43,040
25.4	49,550
27.3	55,310
28.7	59,900
30.0	63,630
30.8	66,210
32.1	70,080

ROCKY MOUNTAIN PROJECT
 LOWER RESERVOIR MAIN SPILLWAY
 1:40 Scale Spillway Model III

Table 13. SPILLWAY WATER SURFACE SURVEY

Reservoir Elevation 710.0 ft
 Flow Over Spillway 37,200 cfs

Bay Number	Distance from Crest, ft.	Water Surface Elevation, Ft.				
		1	2	3	4	5
1	0	707.1	706.7	706.5	706.7	708.4
	4	703.2	704.7	705.3	706.3	706.9
	8	698.2	701.8	703.5	704.7	703.2
	12	694.9	698.4	701.2	702.5	699.9
	16	691.4	694.8	698.7	699.6	697.0
	20	686.8	690.9	695.2	696.1	694.1
	24	682.0	686.7	691.5	692.7	690.5
	28	678.3	682.3	687.3	688.3	686.7
	32	673.0	676.8	682.6	683.7	682.4
	36	N/A	672.4	677.5	679.0	677.5
40	N/A	N/A	672.4	674.0	672.4	
2	0	708.3	706.5	706.2	706.6	708.2
	4	706.4	705.9	705.0	705.8	706.3
	8	702.4	703.7	702.6	703.9	702.0
	12	698.4	701.5	701.6	701.2	697.9
	16	695.0	698.2	699.4	698.0	694.1
	20	691.5	694.4	696.9	694.4	690.4
	24	688.3	690.4	694.1	690.2	687.0
	28	683.8	686.3	690.4	686.0	682.2
	32	679.9	681.7	686.0	681.0	677.4
	36	676.3	675.7	680.7	675.6	N/A
40	N/A	N/A	675.3	N/A	N/A	
3	0	708.6	706.9	706.6	706.5	707.0
	4	706.9	706.6	705.4	704.4	703.4
	8	703.2	705.0	703.6	701.5	699.2
	12	700.7	702.8	701.3	698.4	696.2
	16	698.2	699.8	698.3	695.0	693.2
	20	695.0	697.0	695.6	691.5	689.7
	24	692.1	693.2	691.8	687.0	684.9
	28	688.3	689.3	687.4	682.2	680.4
	32	684.8	685.0	682.9	676.5	N/A
	36	680.2	679.9	678.0	N/A	N/A
40	675.4	674.6	673.4	N/A	N/A	

Note: Data correspond to Figure 6.

ROCKY MOUNTAIN PROJECT
 LOWER RESERVOIR MAIN SPILLWAY
 1:40 Scale Spillway Model III

Table 14. SPILLWAY WATER SURFACE SURVEY

Reservoir Elevation 714.1 ft
 Flow Over Spillway 48,000 cfs

Bay Number	Distance from Crest. ft.	Water Surface Elevation, Ft.				
		1	2	3	4	5
1	0	710.5	710.0	710.1	710.3	712.4
	4	706.9	708.1	709.0	710.0	711.1
	8	702.2	705.0	707.0	706.6	707.8
	12	699.4	702.1	705.0	706.1	704.0
	16	696.6	697.9	701.8	704.0	701.2
	20	693.3	695.0	698.8	700.8	698.2
	24	688.8	690.4	695.2	697.1	695.2
	28	684.2	685.5	690.5	693.2	691.4
	32	677.4	680.4	686.6	688.6	688.0
	36	N/A	N/A	681.4	683.8	683.2
40	N/A	N/A	677.4	678.2	678.6	
2	0	712.0	710.0	709.6	710.0	711.9
	4	710.7	709.6	708.5	709.5	710.7
	8	706.5	707.6	707.2	707.7	706.3
	12	702.8	705.4	705.5	705.3	702.3
	16	699.2	702.5	703.8	701.9	698.2
	20	695.9	698.9	702.0	698.4	695.0
	24	692.1	695.0	699.0	694.4	690.3
	28	688.5	690.8	695.2	690.4	686.8
	32	684.2	686.0	690.7	685.6	681.6
	36	679.4	681.4	685.7	681.0	677.4
40	N/A	676.4	680.6	676.0	N/A	
3	0	712.4	710.3	709.9	709.9	710.3
	4	711.2	710.0	708.7	707.6	706.5
	8	707.6	708.9	707.2	704.4	702.2
	12	705.2	707.0	704.9	701.3	698.5
	16	702.2	704.1	701.8	697.8	695.8
	20	699.5	701.0	698.9	694.2	693.5
	24	696.2	697.8	695.3	690.0	689.6
	28	692.8	694.2	691.4	685.6	684.2
	32	689.0	689.4	687.0	680.7	677.0
	36	684.9	684.4	682.2	675.0	N/A
40	680.9	679.9	677.7	N/A	N/A	

Note: Data correspond to Figure 6.

ROCKY MOUNTAIN PROJECT
 LOWER RESERVOIR MAIN SPILLWAY
 1:40 Scale Spillway Model III

Table 15. SPILLWAY WATER SURFACE SURVEY

Reservoir Elevation 718.0 ft
 Flow Over Spillway 57,600 cfs

Bay Number	Distance from Crest. ft.	Water Surface Elevation, Ft.				
		1	2	3	4	5
1	0	714.6	713.8	713.7	713.9	714.1
	4	709.9	711.0	712.4	713.6	715.2
	8	713.1	708.0	710.7	712.5	712.0
	12	701.9	704.4	711.7	710.4	708.4
	16	699.3	700.6	705.2	708.2	705.3
	20	696.4	697.6	702.0	705.0	703.0
	24	692.3	693.6	698.2	701.7	699.5
	28	689.3	688.5	694.5	698.3	696.6
	32	686.2	683.3	690.5	693.4	692.9
	36	677.8	677.0	686.0	689.6	688.3
	40	N/A	N/A	680.2	683.5	683.5
2	0	715.9	713.7	713.2	713.6	715.5
	4	714.4	713.2	712.2	713.1	714.3
	8	710.2	711.6	710.8	711.4	710.3
	12	706.0	709.1	709.4	708.8	706.0
	16	702.7	706.1	708.4	705.8	702.4
	20	699.8	703.0	706.2	702.0	698.7
	24	696.4	699.5	703.4	698.9	695.0
	28	693.0	695.2	699.7	695.0	691.0
	32	688.8	691.5	695.4	690.2	687.4
	36	684.3	685.9	690.8	685.7	682.7
	40	679.2	681.4	685.0	680.6	677.0
3	0	716.4	713.9	713.7	713.5	713.9
	4	715.4	714.0	712.3	711.1	709.4
	8	712.1	712.7	710.7	707.6	705.2
	12	709.1	710.7	708.3	704.1	701.1
	16	706.7	708.4	705.3	700.8	697.8
	20	704.0	705.4	702.4	697.4	694.7
	24	701.0	702.1	698.7	693.8	691.0
	28	697.8	698.6	695.2	689.6	686.7
	32	694.0	694.8	691.9	685.2	681.5
	36	690.1	689.9	687.2	680.3	676.7
	40	685.8	685.0	682.2	N/A	N/A

Note: Data correspond to Figure 6.

ROCKY MOUNTAIN PROJECT
 LOWER RESERVOIR MAIN SPILLWAY
 1:40 Scale Spillway Model III

Table 16. SPILLWAY WATER SURFACE SURVEY

Reservoir Elevation 720.9 ft
 Flow Over Spillway 66,500 cfs

Bay Number	Distance from Crest, ft.	Water Surface Elevation, Ft.				
		1	2	3	4	5
1	0	716.8	716.3	716.9	716.9	719.0
	4	712.4	713.4	715.3	716.3	718.3
	8	708.6	710.0	713.0	715.4	714.9
	12	705.1	707.1	710.4	713.9	711.8
	16	701.6	703.7	707.4	711.1	709.3
	20	699.3	700.9	704.6	708.1	706.6
	24	695.8	697.6	701.2	705.1	703.6
	28	687.8	693.0	698.0	701.5	700.1
	32	688.1	689.3	693.7	697.5	696.5
	36	683.3	684.6	690.1	693.0	692.7
2	40	678.1	678.9	685.1	687.8	688.0
	0	718.4	716.5	716.0	716.3	718.5
	4	717.1	716.0	715.0	717.5	717.3
	8	713.6	714.2	713.7	714.3	713.1
	12	709.1	711.4	712.1	711.7	709.2
	16	706.0	708.7	710.4	708.8	705.2
	20	703.3	706.1	709.5	705.6	701.8
	24	699.2	702.2	706.4	702.2	697.8
	28	695.8	698.4	703.0	698.5	694.8
	32	692.4	694.6	698.8	694.5	691.8
3	36	689.8	689.8	693.2	689.6	686.6
	40	684.8	685.5	689.4	685.1	681.7
	0	718.8	716.9	716.5	716.4	716.9
	4	718.0	716.4	715.0	713.6	712.1
	8	715.2	715.5	713.2	710.2	707.3
	12	712.5	713.8	710.9	706.6	701.9
	16	709.8	710.5	707.9	702.9	697.1
	20	707.0	708.4	704.8	700.2	692.6
	24	703.6	705.4	701.8	695.8	689.7
	28	701.0	702.2	698.1	691.7	681.4
3	32	697.0	697.9	695.1	687.3	676.2
	36	693.8	693.8	691.3	682.7	N/A
	40	689.7	689.0	687.4	N/A	N/A

Note: Data correspond to Figure 6.

ROCKY MOUNTAIN PROJECT
 LOWER RESERVOIR MAIN SPILLWAY
 1:40 Scale Spillway Model III

Table 17. SPILLWAY WATER SURFACE SURVEY
 Reservoir Elevation 721.0 ft
 Flow Over Spillway 69,600 cfs

Bay Number	Distance from Crest. ft.	Water Surface Elevation, Ft.				
		1	2	3	4	5
1	0	717.0	716.4	716.5	716.8	719.3
	4	712.7	713.7	715.0	716.5	718.5
	8	707.8	710.2	713.3	715.6	715.0
	12	704.7	706.8	710.0	713.8	712.2
	16	701.8	703.6	707.7	711.4	709.2
	20	698.8	700.5	705.0	708.6	706.7
	24	696.6	697.9	700.9	705.5	703.7
	28	692.9	693.6	698.2	701.7	700.4
	32	690.5	689.9	693.9	697.4	697.2
	36	685.4	685.4	690.8	693.2	692.7
40	678.3	679.6	685.8	688.1	688.1	
2	0	718.6	716.4	716.0	716.5	718.6
	4	717.2	716.1	715.1	716.0	717.4
	8	713.6	714.3	713.8	714.4	713.2
	12	709.0	711.3	713.0	711.7	709.2
	16	705.7	708.8	711.8	709.4	705.4
	20	703.0	705.9	709.7	706.0	702.2
	24	700.2	701.7	706.5	702.6	698.4
	28	696.1	698.7	702.9	698.4	694.2
	32	693.6	694.4	698.6	695.0	691.5
	36	688.8	689.7	693.9	691.2	686.4
40	685.2	686.4	689.0	685.8	681.4	
3	0	719.2	716.8	716.2	716.4	717.2
	4	718.3	716.7	715.2	714.0	712.6
	8	715.2	715.8	713.2	710.2	707.8
	12	712.3	713.9	711.1	706.6	702.1
	16	710.4	711.6	708.5	702.9	695.6
	20	707.3	709.2	704.8	699.7	693.7
	24	704.7	705.5	702.2	695.6	689.8
	28	701.4	701.9	698.4	691.4	685.2
	32	697.7	698.1	694.7	686.7	679.0
	36	693.2	694.6	690.2	681.4	673.2
40	685.8	685.8	686.3	677.3	N/A	

Note: Data correspond to Figure 6.

ROCKY MOUNTAIN PROJECT
LOWER RESERVOIR MAIN SPILLWAY
1:40 Scale Spillway Model IV

Table 18. SPILLWAY RATING, UNGATED FLOW

Head, ft	Discharge, cfs
15.6	23,520
18.6	30,360
20.6	35,930
23.2	42,950
25.4	49,470
27.2	55,250
29.0	60,570
30.7	65,200
31.8	68,870
32.6	71,500

ROCKY MOUNTAIN PROJECT
LOWER RESERVOIR MAIN SPILLWAY
1:40 Scale Spillway Model V

Table 19. SPILLWAY RATING, UNGATED FLOW

Head, ft	Discharge, cfs
16.6	25,370
20.7	35,480
23.5	43,290
25.8	49,890
27.3	54,220
29.0	59,380
30.6	64,350
32.2	69,200
33.2	72,860

ROCKY MOUNTAIN PROJECT
LOWER RESERVOIR MAIN SPILLWAY
1:40 Scale Spillway Model VI

Table 20. SPILLWAY RATING, UNGATED FLOW

Head, ft	Discharge, cfs
14.4	21,430
18.7	31,750
21.6	39,530
24.1	47,310
26.1	53,110
27.9	58,650
29.6	63,900
31.0	68,550
32.2	72,890

ROCKY MOUNTAIN PROJECT
LOWER RESERVOIR MAIN SPILLWAY
1:40 Scale Spillway Model VII

Table 21. SPILLWAY RATING, UNGATED FLOW

Head, ft	Discharge, cfs
14.4	20,390
19.1	32,180
22.2	40,640
24.7	47,610
26.6	53,690
28.3	59,140
30.0	64,120
31.6	68,970
32.8	72,860

ROCKY MOUNTAIN PROJECT
LOWER RESERVOIR MAIN SPILLWAY
1:40 Scale Spillway Model VIII

Table 22. SPILLWAY RATING, UNGATED FLOW

Head, ft	Discharge, cfs
12.1	16,650
17.0	27,600
20.7	37,110
23.5	44,640
25.5	50,750
27.6	56,770
29.1	61,940
30.5	66,730
31.9	70,960

ROCKY MOUNTAIN PROJECT
LOWER RESERVOIR MAIN SPILLWAY
1:40 Scale Spillway Model IX

Table 23. SPILLWAY RATING, UNGATED FLOW

Head, ft	Discharge, cfs
12.2	17,530
17.8	30,360
21.1	39,200
23.6	46,380
25.6	52,600
27.5	58,150
29.3	63,210
30.8	67,900
32.0	71,840

ROCKY MOUNTAIN PROJECT
LOWER RESERVOIR MAIN SPILLWAY
1:40 Scale Spillway Model X

Table 24. SPILLWAY RATING, UNGATED FLOW

Head, ft	Discharge, cfs
15.6	24,800
19.3	34,640
22.8	44,710
25.2	52,600
27.1	58,400
28.8	63,470
30.3	67,900
31.6	71,840

ROCKY MOUNTAIN PROJECT
LOWER RESERVOIR MAIN SPILLWAY
1:40 Scale Spillway Model XI

Table 25. SPILLWAY RATING, UNGATED FLOW

Head, ft	Discharge, cfs
15.6	24,800
19.3	34,640
22.8	44,710
25.1	51,030
26.6	56,470
28.4	61,920
29.8	66,700
31.3	71,360

ROCKY MOUNTAIN PROJECT
LOWER RESERVOIR MAIN SPILLWAY
1:40 Scale Spillway Model XII

Table 26. SPILLWAY RATING, UNGATED FLOW

Head, ft	Discharge, cfs
16.2	25,920
19.9	36,730
22.6	44,320
24.6	50,780
26.3	56,510
27.9	61,710
29.5	66,510
30.7	70,980

ROCKY MOUNTAIN PROJECT
 LOWER RESERVOIR MAIN SPILLWAY
 1:40 Scale Spillway Model XII

TABLE 27. SPILLWAY WATER SURFACE SURVEY

Reservoir Elevation 718.8 ft
 Flow Over Spillway 63,700 cfs

Bay Number	Distance from Crest, ft.	1	2	3	4	5
1	0	710.1	712.2	713.4	713.6	714.4
	4	706.8	710.0	711.3	712.5	714.2
	8	702.4	707.4	709.4	711.2	716.2
	12	699.7	704.7	705.5	709.4	712.6
	16	696.6	701.1	705.0	708.8	709.0
	20	693.7	697.6	701.9	706.6	705.6
	24	690.4	693.4	699.0	703.4	701.9
	28	687.4	689.5	695.3	700.1	697.3
	32	682.4	685.5	691.3	695.6	693.1
	36	678.8	679.7	686.0	691.6	688.2
	40	676.3*	674.6*	681.7	686.6	683.3
2	0	714.3	713.8	713.6	713.8	714.4
	4	714.2	712.6	712.4	712.7	714.2
	8	715.0	711.6	711.1	711.8	715.7
	12	710.6	710.0	709.5	710.7	710.4*
	16	707.1	708.6	707.7	709.6	704.8*
	20	703.0	706.0	705.8	707.0	701.8*
	24	699.9	702.5	703.3	703.2	697.6
	28	695.5	698.7	701.6	699.2	693.6
	32	692.1	694.4	698.1	695.2	689.4
	36	686.4	689.6	695.4	690.2	684.7
	40	680.5	684.7	691.0	683.8	679.1
3	0	714.6	713.6	713.0	711.4	709.0
	4	714.5	712.6	711.0	709.3	705.0
	8	717.0	711.5	709.3	706.9	701.8
	12	712.3	710.0	707.4	703.9	697.9
	16	708.7	709.8	705.3	700.1	694.2*
	20	706.1	707.0	702.5	697.4	690.3
	24	702.4	703.4	699.4	693.3	686.1
	28	698.4	699.8	695.8	688.7	681.4
	32	694.0	695.8	694.1	683.1	675.4
	36	689.9	690.7	690.4	678.6	670.3
	40	685.1	685.8	685.9	673.6	667.0*

Note: Data correspond to Figure 6.

ROCKY MOUNTAIN PROJECT
 LOWER RESERVOIR MAIN SPILLWAY
 1:40 Scale Spillway Model XII

Table 28. SPILLWAY WATER SURFACE SURVEY

Reservoir Elevation 720.8 ft
 Flow Over Spillway 70,600 cfs

Bay Number	Distance from Crest, ft.	1	2	3	4	5
1	0	711.0	713.2	714.6	715.2	716.2
	4	707.5	710.6	713.	713.9	716.0
	8	703.4	709.0	711.1	712.7	717.9
	12	700.6	705.6	709.2	711.4	714.5
	16	697.8	701.7	706.7	711.0	710.9
	20	694.8	698.7	703.3	707.8	707.3
	24	690.1	695.3	698.4	705.1	703.8
	28	686.8	690.0	696.5	701.5	699.7
	32	683.0	686.0	692.6	697.4	695.3
	36	679.3	680.6	688.0	692.2	690.1
	40	N/A*	N/A*	682.9	685.4	685.8
2	0	716.0	715.6	715.4	715.4	715.9
	4	715.8	714.2	714.0	714.2	715.7
	8	717.0	712.9	712.8	713.1	717.3
	12	712.7	711.8	711.3	712.0	713.0
	16	709.2	710.3	709.6	711.6	706.1
	20	704.8	707.9	707.3	709.0	N/A*
	24	702.1	704.7	705.6	705.7	N/A*
	28	698.2	700.8	702.9	701.7	695.5
	32	694.0	697.0	700.8	697.4	691.9
	36	689.0	691.8	697.1	690.4	686.2
	40	685.2	688.1	693.8	687.2	682.2
3	0	716.0	715.2	714.3	712.7	709.9
	4	716.3	714.0	712.7	710.5	706.2
	8	718.2	712.8	710.6	707.6	702.2
	12	714.2	714.2	709.1	705.5	699.0
	16	711.2	712.0	706.5	701.8	694.7
	20	708.2	708.6	703.8	697.9	690.9
	24	705.1	705.5	701.4	694.6	686.8
	28	700.1	701.8	697.4	689.3	681.8
	32	697.0	697.4	695.0	685.0	676.2
	36	691.8	693.1	691.5	680.2	N/A*
	40	687.1	688.6	687.6	673.6	N/A*

Note: Data correspond to Figure 6.

ROCKY MOUNTAIN PROJECT
LOWER RESERVOIR MAIN SPILLWAY
1:40 Scale Spillway Model
30 Ft. Bay Width

Table 29. SPILLWAY RATING, UNGATED FLOW

Head, ft	Discharge, cfs
18.3	30,360
21.5	39,980
24.9	49,910
28.1	60,220
30.9	69,250

ROCKY MOUNTAIN PROJECT
 LOWER RESERVOIR MAIN SPILLWAY
 1:40 Scale Hydraulic Model

Table 30. SPILLWAY WATER SURFACE SURVEY
 SPILLWAY MODEL XIII

Bay Number	Distance from Crest, ft.	Water Surface Elevation, ft.				
		1	2	3	4	5
1	0	704	704	705	706	707
	4	702	702	704	704	706
	8	699	700	701	702	704
	12	604	695	695	698	698
	16	603	694	694	697	696
	20	688	690	691	693	692
	24	684	687	688	689	688
	28	678	680	682	683	681
	32	676	678	680	680	679
	36	671	672	675	675	674
2	40	667	669	670	670	669
	0	707	706	706	706	707
	4	705	704	704	704	706
	8	703	702	702	703	703
	12	696	698	698	699	697
	16	694	697	697	697	695
	20	690	693	694	694	691
	24	686	688	690	690	686
	28	680	682	685	683	680
	32	677	679	681	680	677
3	36	672	674	678	675	673
	40	668	670	673	671	668
	0	707	706	705	705	703
	4	706	705	704	703	701
	8	704	703	701	700	699
	12	698	699	697	695	694
	16	696	697	695	694	692
	20	692	695	693	690	688
	24	687	689	689	686	683
	28	681	683	683	680	676
32	678	679	680	677	674	
36	673	674	675	672	669	
40	670	670	670	669	666	

COMMENTS:

Q = 40,700 cfs.
 Reservoir Elevation = 712 ft.

ROCKY MOUNTAIN PROJECT
 LOWER RESERVOIR MAIN SPILLWAY
 1:40 Scale Hydraulic Model

Table 31. SPILLWAY WATER SURFACE SURVEY
 SPILLWAY MODEL XIII

Bay Number	Distance from Crest, ft.	Water Surface Elevation, ft.				
		1	2	3	4	5
1	0	707	708	709	711	712
	4	705	707	708	709	711
	8	703	705	705	707	709
	12	698	700	701	704	704
	16	696	698	700	702	702
	20	692	695	697	698	698
	24	688	691	692	694	694
	28	682	686	688	689	688
	32	680	681	685	686	684
	36	675	678	681	680	679
2	40	672	674	676	676	675
	0	712	711	711	711	712
	4	711	710	709	710	711
	8	708	707	707	708	708
	12	702	704	704	704	703
	16	701	703	702	703	701
	20	696	699	699	699	697
	24	691	695	696	695	692
	28	686	690	692	690	687
	32	682	686	689	687	683
36	680	681	684	682	677	
3	40	673	677	680	677	674
	0	712	711	710	709	708
	4	711	709	708	706	705
	8	709	707	705	704	701
	12	704	705	701	700	696
	16	702	702	700	697	695
	20	697	699	700	694	690
	24	693	694	693	689	685
	28	688	690	690	685	680
	32	685	687	686	682	677
36	680	681	681	677	673	
40	676	677	676	673	669	

COMMENTS:

Q = 60,000 cfs.
 Reservoir Elevation = 718 ft.

ROCKY MOUNTAIN PROJECT
LOWER RESERVOIR MAIN SPILLWAY
1:40 Scale Hydraulic Model

Table 32. LOW DISCHARGE SPILLWAY RATING, UNGATED FLOWS
SPILLWAY MODEL XIII

Reservoir Elevation, ft	Discharge, cfs
690.9	360
691.0	510
691.5	770
692.1	1,120
692.4	1,330
692.6	1,510
692.8	1,670
694.2	3,010
695.8	4,940
696.8	6,480
697.5	7,540
698.4	9,040
698.8	9,590
701.2	14,100

ROCKY MOUNTAIN PROJECT
 LOWER RESERVOIR MAIN SPILLWAY
 1:40 Scale Hydraulic Model

Table 33. Gated Spillway Discharges - Hysteresis Study
 Spillway Model XIII
 Gate Openings = 20 ft.

Discharge cfs	Status	Reservoir Elevation ft.	Comments
48450	1 ¹⁰ UG 3 ^{10*}	714.8	Rising Discharges
49040	1 ¹⁰ UG 3 ^{10*}	715.0	"
40610	1 ¹⁰ UG 3 ^{10*}	715.2	"
50035	1 ¹⁰ UG 3 ^{10*}	715.4	"
50720	1 ²⁵ UG 3 ^{25*}	715.6	"
51130	1 ⁵⁰ UG 3 ^{50*}	715.7	"
51790	1 ⁵⁰ UG 3 ^{50*}	716.0	"
52305	1 ⁷⁵ UG 3 ^{75*}	716.2	"
52685	Crested	721.2	Flow Topped Tainters
51920	Crested	720.4	Falling Discharges
51525	Crested	720.1	Flow Topped Tainters
50995	Crested	719.4	"
50585	Gated	718.1	"
50175	1 ²⁵ UG 3 ²⁵	715.4	"

*

Partly sealed tainter gates: numbers indicate partial sealing in respective bay, superscripted numbers indicate estimated percentage of sealing of tainter gates: UG = ungated flow.

ROCKY MOUNTAIN PROJECT
 LOWER RESERVOIR MAIN SPILLWAY
 1:40 Scale Hydraulic Model

Table 34. Gated Spillway Discharges - Hysteresis Study
 Spillway Model XIII
 Gate Openings = 20 ft.

Discharge cfs	Status	Reservoir Elevation ft.	Comments
51130	1 ⁵⁰ UG 3 ^{50*}	715.7	Rising Discharges
51790	1 ⁵⁰ UG 3 ^{50*}	715.9	"
52045	1 ⁶⁰ UG 3 ^{60*}	716.0	"
52305	1 ⁷⁵ UG 3 ^{75*}	716.1	"
52430	1 ⁷⁵ 2 ⁷⁵ 3 ^{75*}	716.2	"
52685	Crested	721.2	"
52175	Crested	720.9	Falling Discharges
51655	Crested	720.0	"
51260	Gated	719.6	"
50860	Gated	718.9	"
50720	Gated	718.1	"
50450	Gated	717.7	"
50175	1 ²⁵ UG 3 ^{25*}	715.3	"

*
 Partly sealed tainter gates: numbers indicate partial sealing in respective bay, superscripted numbers indicate estimated percentage of sealing of tainter gates: UG = ungated flow.

ROCKY MOUNTAIN PROJECT
 LOWER RESERVOIR MAIN SPILLWAY
 1:40 Scale Hydraulic Model

Table 35. Gated Spillway Discharges - Hysteresis Study
 Spillway Model XIII
 Gate Openings = 15 ft.

Discharge cfs	Status	Reservoir Elevation ft.	Comments
31050	Ungated	708.5	Rising Discharges
32980	1 ²⁵ UG 3 ^{25*}	709.2	"
33345	1 ²⁵ UG 3 ^{25*}	709.4	"
33700	1 ⁵⁰ UG 3 ^{50*}	709.6	"
34230	1 ⁵⁰ UG 3 ^{50*}	709.8	"
34570	Gated	714.0	"
34230	Gated	713.4	Falling Discharges
33880	Gated	712.8	"
33345	Gated	711.9	"
32980	1 ²⁵ UG 3 ^{25*}	709.2	"
33345	1 ⁵⁰ UG 3 ^{50*}	709.4	Rising Discharges
33880	1 ⁵⁰ UG 3 ^{50*}	709.7	"
34230	Gated	713.6	"
34400	Gated	713.8	"
33700	Gated	713.0	Falling Discharges
33525	Gated	712.4	"
33345	Gated	712.2	"
33165	Gated	711.7	"
32980	1 ²⁵ UG 3 ^{25*}	709.3	"

* Partly sealed tainter gates: numbers indicate partial sealing in respective bay, superscripted numbers indicate estimated percentage of sealing of tainter gates; UG = ungated flow.

ROCKY MOUNTAIN PROJECT
 LOWER RESERVOIR MAIN SPILLWAY
 1:40 Scale Hydraulic Model

Table 36. Gated Spillway Discharges - Hysteresis Study
 Spillway Model XIII
 Gate Openings = 10 ft.

Discharge cfs	Status	Reservoir Elevation ft.	Comments
14060	Ungated	701.2	Rising Discharges
15770	Ungated	702.0	"
18180	Ungated	703.2	"
18885	1 ⁴⁰ UG 3 ^{40*}	703.5	"
19360	Gated	706.7	"
18885	Gated	706.0	Falling Discharges
18795	Gated	705.7	"
18550	Gated	705.1	"
18305	Ungated	703.2	"
18640	1 ⁴⁰ UG 3 ^{40*}	703.4	Rising Discharges
19065	1 ⁴⁰ UG 3 ^{40*}	703.6	"
19330	Gated	706.6	"
18795	Gated	705.8	Falling Discharges
18640	Gated	705.5	"
18240	Ungated	703.2	"

* Partly sealed tainter gates: numbers indicate partial sealing in respective bays, superscripted numbers indicate estimated percentage of sealing of tainter gates; UG = ungated flow.

ROCKY MOUNTAIN PROJECT
 LOWER RESERVOIR MAIN SPILLWAY
 1:40 Scale Hydraulic Model

Table 37. Gated Spillway Discharges - Hysteresis Study
 Spillway Model XIII
 Gate Openings = 5 ft.

Discharge cfs	Status	Reservoir Elevation ft.	Comments
7610	1 ⁵⁰ UG 3 ^{50*}	697.6	Rising Discharges
8185	Gated	700.5	"
8980	Gated	702.5	"
8850	Gated	702.3	"
8390	Gated	701.2	Falling Discharges
7760	Gated	699.6	"
7460	Gated	698.7	"
6990	Ungated	697.3	"
9825	Gated	705.0	Falling Discharges
9230	Gated	703.1	"
8850	Gated	702.2	"
8660	Gated	701.4	"
8185	Gated	700.6	"
7905	Gated	699.8	"
7150	Ungated	697.4	"

* Partly sealed tainter gates: numbers indicate partial sealing in respective bays, superscripted numbers indicate estimated percentage of sealing of tainter gates: UG = ungated flow.

ROCKY MOUNTAIN PROJECT
 LOWER RESERVOIR MAIN SPILLWAY
 1:40 Scale Hydraulic Model

Table 38. Rating of Tainter Gates, 30-foot Bays
 Gate Openings: North 0 in.
 Center 8 in.
 South 0 in.

Reservoir Elev. ft. (MSL)	Discharge (cfs)
691.1*	209
691.4**	320
695.2**	401
702.8**	581

*Free overflow
 **Gated spillway discharge

ROCKY MOUNTAIN PROJECT
 LOWER RESERVOIR MAIN SPILLWAY
 1:40 Scale Hydraulic Model

Table 39. Rating of Tainter Gates, 30-foot Bays
 Gate Openings: North 8 in.
 Center 8 in.
 South 8 in.

Reservoir Elev. ft. (MSL)	Discharge (cfs)
691.0*	469
693.7**	766
700.0**	1,076
708.9**	1,365

*Free overflow
 **Gated spillway discharge

ROCKY MOUNTAIN PROJECT
 LOWER RESERVOIR MAIN SPILLWAY
 1:40 Scale Hydraulic Model

Table 40. Rating of Tainter Gates, 30-foot Bays
 Gate Openings: North 16 in.
 Center 16 in.
 South 16 in.

Reservoir Elev. ft (MSL)	Discharge (cfs)
691.3*	593
691.8*	882
694.1**	1,376
696.6**	1,629

*Free overflow
 **Gated spillway discharge

ROCKY MOUNTAIN PROJECT
 LOWER RESERVOIR MAIN SPILLWAY
 1:40 Scale Hydraulic Model

Table 41. Rating of Tainter Gates, 30-foot Bays
 Gate Openings: North 0 in.
 Center 24 in.
 South 0 in.

Reservoir Elev. ft (MSL)	Discharge (cfs)
692.9*	685
694.8**	803
702.0**	1,149
706.8**	1,338

*Free overflow
 **Gated spillway discharge

ROCKY MOUNTAIN PROJECT
 LOWER RESERVOIR MAIN SPILLWAY
 1:40 Scale Hydraulic Model

Table 42. Rating of Tainter Gates, 30-foot Bays
 Gate Openings: North 0 in.
 Center 32 in.
 South 0 in.

Reservoir Elev. ft (MSL)	Discharge (cfs)
693.2*	776
693.9*	999
694.6*	1,235
697.9**	1,433
699.0**	1,532
700.4**	1,624

*Free overflow
 **Gated spillway discharge

ROCKY MOUNTAIN PROJECT
 LOWER RESERVOIR MAIN SPILLWAY
 1:40 Scale Hydraulic Model

Table 43. Rating of Tainter Gates, 30-foot Bays
 Gate Openings: North 0 in.
 Center 48 in.
 South 0 in.

Reservoir Elev. ft (MSL)	Discharge (cfs)
695.2*	1,428
695.5*	1,546
695.8*	1,652
700.6**	1,846
701.8**	2,383

*Free overflow
 **Gated spillway discharge

ROCKY MOUNTAIN PROJECT
LOWER RESERVOIR MAIN SPILLWAY
1:40 Scale Hydraulic Model

Table 44. Rating of Tainter Gates, 30-foot Bays
Gate Openings: North 0 ft.
Center 4 ft.
South 0 ft.

Reservoir Elev. ft. (MSL)	Discharge (cfs)
696	1,505
709	3,015
711	3,840
711	3,990
712	4,765

ROCKY MOUNTAIN PROJECT
LOWER RESERVOIR MAIN SPILLWAY
1:40 Scale Hydraulic Model

Table 45. Rating of Tainter Gates, 30-foot Bays
Gate Openings: North 0 ft.
Center 5 ft.
South 0 ft.

Reservoir Elev. ft. (MSL)	Discharge (cfs)
696	1,845
703	3,200
704	3,370
711	4,645

ROCKY MOUNTAIN PROJECT
 LOWER RESERVOIR MAIN SPILLWAY
 1:40 Scale Hydraulic Model

Table 46. Rating of Tainter Gates, 30-foot Bays
 Gate Openings: North 1 ft.
 Center 5 ft.
 South 1 ft.

Reservoir Elev. ft. (MSL)	Discharge (cfs)
695	1,845
698	3,370
703	4,645
710	5,640
712	6,480

ROCKY MOUNTAIN PROJECT
LOWER RESERVOIR MAIN SPILLWAY
1:40 Scale Hydraulic Model

Table 47. Rating of Tainter Gates, 30-foot Bays
Gate Openings: North 2 ft.
Center 5 ft.
South 2 ft.

Reservoir Elev. ft. (MSL)	Discharge (cfs)
693	1,845
695	3,370
697	4,645
703	5,840
707	6,820
712	7,610

ROCKY MOUNTAIN PROJECT
LOWER RESERVOIR MAIN SPILLWAY
1:40 Scale Hydraulic Model

Table 48. Rating of Tainter Gates, 30-foot Bays
Gate Openings: North 3 ft.
Center 5 ft.
South 3 ft.

Reservoir Elev. ft. (MSL)	Discharge (cfs)
694	3,200
695	5,220
697	5,930
700	6,570
704	7,380
709	8,115
713	9,040

ROCKY MOUNTAIN PROJECT
LOWER RESERVOIR MAIN SPILLWAY
1:40 Scale Hydraulic Model

Table 49. Rating of Tainter Gates, 30-foot Bays
Gate Openings: North 4 ft.
Center 5 ft.
South 4 ft.

Reservoir Elev. ft. (MSL)	Discharge (cfs)
696	6,030
697	6,655
701	7,830
704	8,525
708	9,530
713	10,440
714	10,867

ROCKY MOUNTAIN PROJECT
 LOWER RESERVOIR MAIN SPILLWAY
 1:40 Scale Hydraulic Model

Table 50. Rating of Tainter Gates, 30-foot Bays
 Gate Openings: North 5 ft.
 Center 5 ft.
 South 5 ft.

Reservoir Elev. ft. (MSL)	Discharge (cfs)
695	4,880
695	5,640
696	6,030
696	6,395
697	7,460
700	8,115
705	9,470
709	10,970
711	11,530
714	12,150
715	12,700

ROCKY MOUNTAIN PROJECT
LOWER RESERVOIR MAIN SPILLWAY
1:40 Scale Hydraulic Model

Table 51. Rating of Tainter Gates, 30-foot Bays
Gate Openings: North 10 ft.
Center 10 ft.
South 10 ft.

Reservoir Elev. ft. (MSL)	Discharge (cfs)
701	14,500
702	16,745
703	18,720
709	20,510
711	22,150
714	23,680
717	25,115
718	26,745

ROCKY MOUNTAIN PROJECT
LOWER RESERVOIR MAIN SPILLWAY
1:40 Scale Hydraulic Model

Table 52. Rating of Tainter Gates, 30-foot Bays
Gate Openings: North 15 ft.
Center 15 ft.
South 15 ft.

Reservoir Elev. ft. (MSL)	Discharge (cfs)
708	30,365
714	35,065
719	39,200

ROCKY MOUNTAIN PROJECT
LOWER RESERVOIR MAIN SPILLWAY
1:40 Scale Hydraulic Model

Table 53. Rating of Tainter Gates, 30-foot Bays
Gate Openings: North 20 ft.
Center 20 ft.
South 20 ft.

Reservoir Elev. ft. (MSL)	Discharge (cfs)
706	24,895
708	30,365
710	35,065
711	39,200
714	46,385
715	49,590
716	52,595
722	55,440

ROCKY MOUNTAIN PROJECT
LOWER RESERVOIR MAIN SPILLWAY
1:40 Scale Hydraulic Model

Table 54. Summary of Dissipator Test Conditions

Bucket Invert Elevations:	635, 630 feet
Exit Lip Angles :	45°, 37.5°, 30° 20°, 10°, 0°
Exit Lip Elevations :	646, 642, 640 feet
Guidewall Flare Angles :	5°, 7.5°, ..., 30°
Guidewall Elevations :	667, 665, 655 feet

ROCKY MOUNTAIN PROJECT
 LOWER RESERVOIR MAIN SPILLWAY
 1:40 Scale Hydraulic Model

Table 55. Flip Bucket Type Energy Dissipator, 45° Angle

Total Flow, cfs.	Tailwater Elev., ft. MSL	Bucket Radius, ft.	End Sill Elev., ft. MSL	Gate Opening	Height Max., ft.	Height Min., ft.	Impact Distance, ft.
30,000	661	25	646	ungated	56	46	93
40,000	663	25	646	ungated	55	39	103
50,000	665	25	646	ungated	56	40	110
60,000	667	25	646	ungated	56	42	117
69,000	669	25	646	ungated	58	44	120

Height is distance above 635 feet.

Impact distance is measured from end of bucket.

ROCKY MOUNTAIN PROJECT
 LOWER RESERVOIR MAIN SPILLWAY
 1:40 Scale Hydraulic Model

Table 56. Tailrace Velocity Survey

STATION	a	b	c	d	e	f
1	N/A	N/A	N/A	N/A	N/A	N/A
2	8	12	10	-7	N/A	N/A
3	8	15	11	-7	N/A	N/A
4	10	14	11	10	N/A	N/A
5	N/A	13	11	9	N/A	N/A
6	1	10	10	10	N/A	N/A
7	1	8	10	9	2	N/A
8	N/A	7	9	9	4	N/A
9	N/A	6	8	8	6	N/A

COMMENTS:

Measurements taken 5 ft. below water surface.
 Tailwater Elev. 661 ft. (MSL)
 Q = 30,000 cfs.
 Wingwalls: 7.5° angles
 Sill Exit Angle 45°
 Sill Exit Elev. 646 ft.
 Values are prototype velocities in fps.

ROCKY MOUNTAIN PROJECT
 LOWER RESERVOIR MAIN SPILLWAY
 1:40 Scale Hydraulic Model

Table 57. Tailrace Velocity Survey

STATION	a	b	c	d	e	f
1	N/A	N/A	N/A	N/A	N/A	N/A
2	5	16	13	-6	-4	N/A
3	7	15	15	7	-4	N/A
4	8	14	18	11	4	N/A
5	10	16	19	15	7	N/A
6	8	16	17	16	11	N/A
7	8	15	17	18	14	N/A
8	N/A	12	16	14	12	3
9	N/A	4	12	10	14	6

COMMENTS:

Measurements taken 5 ft. below water surface.
 Tailwater Elev. 661 ft. (MSL)
 Q = 60,000 cfs.
 Wingwalls: 7.5° angles
 Sill Exit Angle 45°
 Sill Exit Elev. 646 ft.
 Values are prototype velocities in fps.

ROCKY MOUNTAIN PROJECT
 LOWER RESERVOIR MAIN SPILLWAY
 1:40 Scale Hydraulic Model

Table 58. Flip Bucket Type Energy Dissipator, 37.5° Angle

Total Flow, cfs.	Tailwater Elev., ft. MSL	Bucket Radius, ft.	End Sill Elev., ft. MSL	Gate Opening	Height Max., ft.	Height Min., ft.	Impact Distance, ft.
30,000	661	25	646	ungated	48	39	97
40,000	663	25	646	ungated	51	35	100
50,000	665	25	646	ungated	53	40	107
60,000	667	25	646	ungated	57	39	110
69,000	669	25	646	ungated	55	40	110
30,000	661	25	642	ungated	54	44	93
40,000	663	25	642	ungated	55	36	103
50,000	665	25	642	ungated	57	40	113
60,000	667	25	642	ungated	51	38	113
69,000	669	25	642	ungated	49	39	117

Height is distance above 635 feet.

Impact distance is measured from end of bucket.

ROCKY MOUNTAIN PROJECT
 LOWER RESERVOIR MAIN SPILLWAY
 1:40 Scale Hydraulic Model

Table 59. Tailrace Velocity Survey

STATION	a	b	c	d	e	f
1	N/A	N/A	N/A	N/A	N/A	N/A
2	8	12	12	-9	N/A	N/A
3	9	14	11	-7	N/A	N/A
4	N/A	9	8	8	N/A	N/A
5	N/A	10	9	8	N/A	N/A
6	1	9	9	8	N/A	N/A
7	1	9	9	8	6	N/A
8	N/A	9	9	8	7	N/A
9	N/A	7	7	8	8	3

COMMENTS:

Measurements taken 5 ft. below water surface.
 Tailwater Elev. 661 ft. (MSL)
 Q = 30,000 cfs.
 Wingwalls: 7.5° angles
 Sill Exit Angle 37.5°
 Sill Exit Elev. 642 ft.
 Values are prototype velocities in fps.

See Definition Sketch, Figure 80.

ROCKY MOUNTAIN PROJECT
 LOWER RESERVOIR MAIN SPILLWAY
 1:40 Scale Hydraulic Model

Table 60. Tailrace Velocity Survey

STATION	a	b	c	d	e	f
1	N/A	N/A	N/A	N/A	N/A	N/A
2	7	12	12	-8	N/A	N/A
3	8	15	14	-8	N/A	N/A
4	11	9	9	7	N/A	N/A
5	N/A	6	8	7	N/A	N/A
6	4	7	8	8	N/A	N/A
7	2	8	8	9	6	N/A
8	N/A	8	8	9	6	N/A
9	N/A	7	7	8	7	3

COMMENTS:

Measurements taken 5 ft. below water surface.
 Tailwater Elev. 661 ft. (MSL)
 Q = 30,000 cfs.
 Wingwalls: 7.5° angles
 Will Exit Angle 37.5°
 Sill Exit Elev. 646 ft.
 Values are prototype velocities in fps.

See Definition Sketch, Figure 80.

ROCKY MOUNTAIN PROJECT
 LOWER RESERVOIR MAIN SPILLWAY
 1:40 Scale Hydraulic Model

Table 61. Tailrace Velocity Survey

STATION	a	b	c	d	e	f
1	N/A	N/A	N/A	N/A	N/A	N/A
2	7	21	11	-4	-4	N/A
3	6	20	9	-4	N/A	N/A
4	6	16	13	7	N/A	N/A
5	6	14	15	9	N/A	N/A
6	7	13	14	11	8	N/A
7	6	12	14	12	10	1
8	N/A	12	13	12	11	3
9	N/A	12	14	8	10	7

COMMENTS:

Measurements taken 5 ft. below water surface.
 Tailwater Elev. 667 ft. (MSL)
 Q = 60,000 cfs.
 Wingwalls: 7.5° angles
 Sill Exit Angle 37.5°
 Sill Exit Elev. 642 ft.
 Values are prototype velocities in fps.

See Definition Sketch, Figure 80.

ROCKY MOUNTAIN PROJECT
 LOWER RESERVOIR MAIN SPILLWAY
 1:40 Scale Hydraulic Model

Table 62. Tailrace Velocity Survey

STATION	a	b	c	d	e	f
1	N/A	N/A	N/A	N/A	N/A	N/A
2	9	16	12	-8	-4	N/A
3	8	16	14	8	N/A	N/A
4	10	18	17	10	N/A	N/A
5	11	17	19	13	N/A	N/A
6	10	16	16	11	7	N/A
7	5	13	10	11	8	1
8	N/A	11	9	11	8	1
9	N/A	8	10	10	10	4

COMMENTS:

Measurements taken 5 ft. below water surface.
 Tailwater Elev. 667 ft. (MSL)
 Q = 60,000 cfs.
 Wingwalls: 7.5° angles
 Sill Exit Angle 37.5°
 Sill Exit Elev. 646 ft.
 Values are prototype velocities in fps.

See Definition Sketch, Figure 80.

ROCKY MOUNTAIN PROJECT
 LOWER RESERVOIR MAIN SPILLWAY
 1:40 Scale Hydraulic Model

Table 63. Flip Bucket Type Energy Dissipator, 30° Angle

Total Flow, cfs.	Tailwater Elev., ft. MSL	Bucket Radius, ft.	Exit Lip Elev., ft. MSL	Gate Opening	Height Max., ft.	Height Min., ft.	Impact Distance, ft.
30,000	661	25	646	ungated	39	29	93
40,000	663	25	646	ungated	40	30	97
50,000	665	25	646	ungated	40	32	100
60,000	667	25	646	ungated	46	35	103
69,000	669	25	646	ungated	45	37	103
30,000	661	25	640	ungated	46	39	97
40,000	663	25	640	ungated	45	30	103
50,000	665	25	640	ungated	57	49	107
60,000	667	25	640	ungated	53	36	120
69,000	669	25	640	ungated	37	28	70-100*

*Unsteady.

Height is distance above 635 feet.

Impact distance is measured from end of bucket.

ROCKY MOUNTAIN PROJECT
 LOWER RESERVOIR MAIN SPILLWAY
 1:40 Scale Hydraulic Model

Table 64. Tailrace Velocity Survey

STATION	a	b	c	d	e	f
1	N/A	N/A	N/A	N/A	N/A	N/A
2	10	10	11	-2	N/A	N/A
3	11	12	11	-6	N/A	N/A
4	10	6	7	8	N/A	N/A
5	10	7	7	9	N/A	N/A
6	4	8	7	8	N/A	N/A
7	3	9	7	8	6	N/A
8	N/A	9	7	7	7	N/A
9	N/A	8	7	6	7	4

COMMENTS:

Measurements taken 5 ft. below water surface.
 Tailwater Elev. 661 ft. (MSL)
 Q = 30,000 cfs.
 Wingwalls: 7.5° angles
 Sill Exit Angle 30°
 Sill Exit Elev. 640 ft.
 Values are prototype velocities in fps.

See Definition Sketch, Figure 80.

ROCKY MOUNTAIN PROJECT
 LOWER RESERVOIR MAIN SPILLWAY
 1:40 Scale Hydraulic Model

Table 65. Tailrace Velocity Survey

STATION	a	b	c	d	e	f
1	N/A	N/A	N/A	N/A	N/A	N/A
2	9	11	10	-5	N/A	N/A
3	10	13	12	-7	N/A	N/A
4	10	10	6	7	N/A	N/A
5	8	10	5	7	N/A	N/A
6	2	11	6	8	N/A	N/A
7	1	10	6	8	8	N/A
8	N/A	10	7	7	7	N/A
9	N/A	9	7	6	7	4

COMMENTS:

Measurements taken 5 ft. below water surface.
 Tailwater Elev. 661 ft. (MSL)
 Q = 30,000 cfs.
 Wingwalls: 7.5° angles
 Sill Exit Angle 30°
 Sill Exit Elev. 643 ft.
 Values are prototype velocities in fps.

See Definition Sketch, Figure 80.

ROCKY MOUNTAIN PROJECT
 LOWER RESERVOIR MAIN SPILLWAY
 1:40 Scale Hydraulic Model

Table 66. Tailrace Velocity Survey

STATION	a	b	c	d	e	f
1	N/A	N/A	N/A	N/A	N/A	N/A
2	10	14	11	-4	N/A	N/A
3	9	15	11	-4	N/A	N/A
4	7	11	7	6	N/A	N/A
5	7	11	7	7	N/A	N/A
6	N/A	11	7	7	N/A	N/A
7	N/A	10	8	8	6	N/A
8	N/A	9	8	7	6	N/A
9	N/A	7	9	5	6	4

COMMENTS:

Measurements taken 5 ft. below water surface.
 Tailwater Elev. 661 ft. (MSL)
 Q = 30,000 cfs.
 Wingwalls: 7.5° angles
 Sill Exit Angle 30°
 Sill Exit Elev. 646 ft.
 Values are prototype velocities in fps.

See Definition Sketch, Figure 80.

ROCKY MOUNTAIN PROJECT
 LOWER RESERVOIR MAIN SPILLWAY
 1:40 Scale Hydraulic Model

Table 67. Tailrace Velocity Survey

STATION	a	b	c	d	e	f
1	N/A	N/A	N/A	N/A	N/A	N/A
2	6	22	16	-7	-5	N/A
3	7	17	15	-8	N/A	N/A
4	9	17	18	10	N/A	N/A
5	9	18	19	13	N/A	N/A
6	9	16	16	11	6	N/A
7	3	12	7	12	7	1
8	N/A	11	7	11	8	2
9	N/A	9	9	8	9	4

COMMENTS:

Measurements taken 5 ft. below water surface.
 Tailwater Elev. 667 ft. (MSL)
 Q = 60,000 cfs.
 Wingwalls: 7.5° angles
 Sill Exit Angle 30°
 Sill Exit Elev. 640 ft.
 Values are prototype velocities in fps.

See Definition Sketch, Figure 80.

ROCKY MOUNTAIN PROJECT
 LOWER RESERVOIR MAIN SPILLWAY
 1:40 Scale Hydraulic Model

Table 68. Tailrace Velocity Survey

STATION	a	b	c	d	e	f
1	N/A	N/A	N/A	N/A	N/A	N/A
2	12	18	4	-4	N/A	N/A
3	13	11	10	-8	-5	N/A
4	14	15	16	9	3	N/A
5	13	17	18	13	7	N/A
6	15	18	18	17	9	N/A
7	7	17	17	14	10	2
8	N/A	13	11	8	12	4
9	N/A	9	12	9	13	7

COMMENTS:

Measurements taken 5 ft. below water surface.
 Tailwater Elev. 667 ft.
 Q = 60,000 cfs.
 Wingwalls: 7.5° angles
 Sill Exit Angle 30°
 Sill Exit Elev. 646 ft.
 Values are prototype velocities in fps.

See Definition Sketch, Figure 80.

ROCKY MOUNTAIN PROJECT
 LOWER RESERVOIR MAIN SPILLWAY
 1:40 Scale Hydraulic Model

Table 69. Tailrace Velocity Survey

STATION	a	b	c	d	e	f
1	N/A	N/A	N/A	N/A	N/A	N/A
2	6.6	20.2	11.6	4.1	3.5	N/A
3	6.4	19.0	11.8	5.9	N/A	N/A
4	8.0	18.7	17.2	9.3	N/A	N/A
5	8.2	15.2	17.4	8.6	N/A	N/A
6	7.9	15.8	16.9	11.8	8.3	N/A
7	1.5	12.8	10.5	11.1	8.0	0.5
8	N/A	10.1	10.0	11.9	7.1	1.8
9	N/A	8.1	11.6	8.9	8.2	3.9

COMMENTS:

Measurements taken 5 ft. below water surface.
 Tailwater Elev. 667 ft.
 Q = 60,000 cfs.
 Wingwalls: 7.5° angles
 Sill Exit Angle 30°
 Sill Exit Elev. 643 ft.
 Values are prototype velocities in fps.

See Definition Sketch, Figure 80.

ROCKY MOUNTAIN PROJECT
 LOWER RESERVOIR MAIN SPILLWAY
 1:40 Scale Hydraulic Model

Table 70. Flip Bucket Type Energy Dissipator Water Surface Elevations

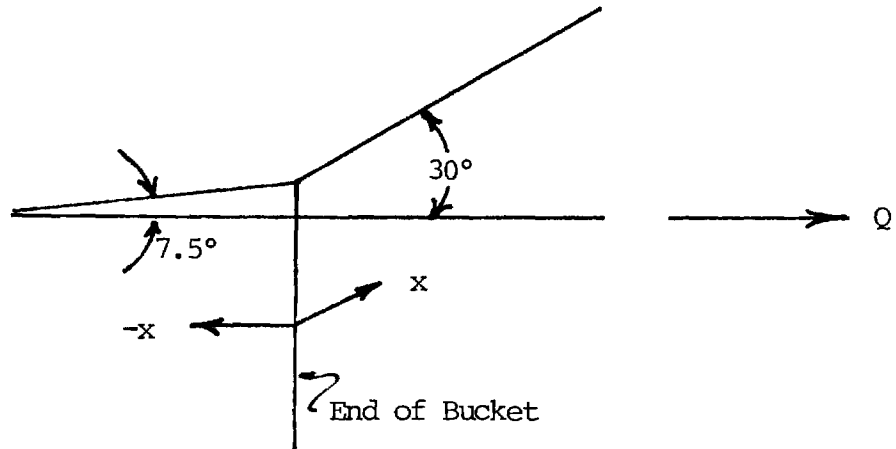

x-feet	NORTH		SOUTH	
	Inside	Outside	Inside	Outside
-50	644	659	645	659
-33	649	659	648	659
-17	654	659	654	659
0	657	659	656	659
17	657	659	656	659
33	658	659	658	659
50	657	659	657	659
67	659	659	659	659
83	659	659	659	659

Comments:

Water Surface Elevations in ft. (MSL)
 Top of Wall at 667 ft.
 Q = 20,000 cfs.
 Reservoir Elevation = 705 ft.
 Tailwater Elevation = 659 ft.

ROCKY MOUNTAIN PROJECT
 LOWER RESERVOIR MAIN SPILLWAY
 1:40 Scale Hydraulic Model

Table 71. Flip Bucket Type Energy Dissipator Water Surface Elevations

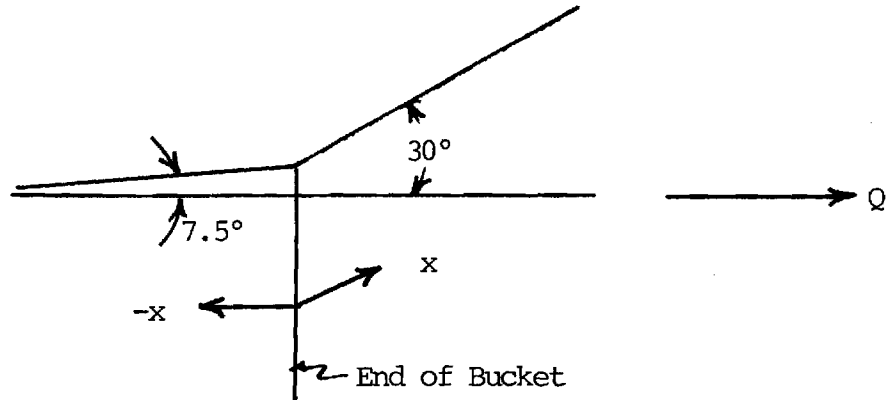

x-feet	NORTH		SOUTH	
	Inside	Outside	Inside	Outside
-50	645	661	644	661
-33	648	662	647	661
-17	652	661	651	661
0	658	661	657	661
17	658	661	658	661
33	659	661	656	661
50	659	661	657	661
67	659	661	659	661
83	659	661	659	661

Comments:

Water Surface Elevations in ft. (MSL)
 Top of Wall at 667 ft.
 Q = 30,000 cfs.
 Reservoir Elevation = 709 ft.
 Tailwater Elevation = 661 ft.

ROCKY MOUNTAIN PROJECT
 LOWER RESERVOIR MAIN SPILLWAY
 1:40 Scale Hydraulic Model

Table 72. Flip Bucket Type Energy Dissipator Water Surface Elevations

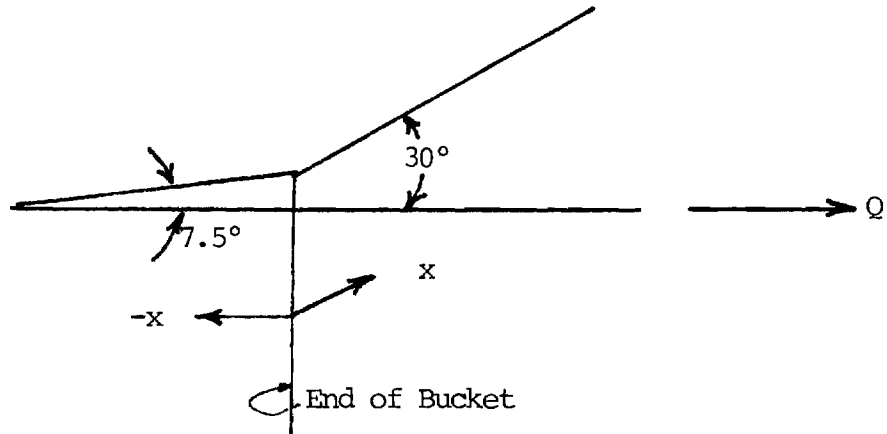

x-feet	NORTH		SOUTH	
	Inside	Outside	Inside	Outside
-50	645	664	645	664
-33	649	664	646	664
-17	653	664	650	664
0	659	664	659	664
17	661	664	661	664
33	662	664	661	664
50	662	665	662	665
67	662	664	662	664
83	662	664	662	664

Comments:

Water Surface Elevations in ft. (MSL)
 Top of Wall at 667 ft.
 Q = 45,000 cfs.
 Reservoir Elevation = 713 ft.
 Tailwater Elevation = 664 ft.

Waves spilled over both North and South walls.
 Estimated height = 5 ft.

ROCKY MOUNTAIN PROJECT
 LOWER RESERVOIR MAIN SPILLWAY
 1:40 Scale Hydraulic Model

Table 73. Flip Bucket Type Energy Dissipator Water Surface Elevations

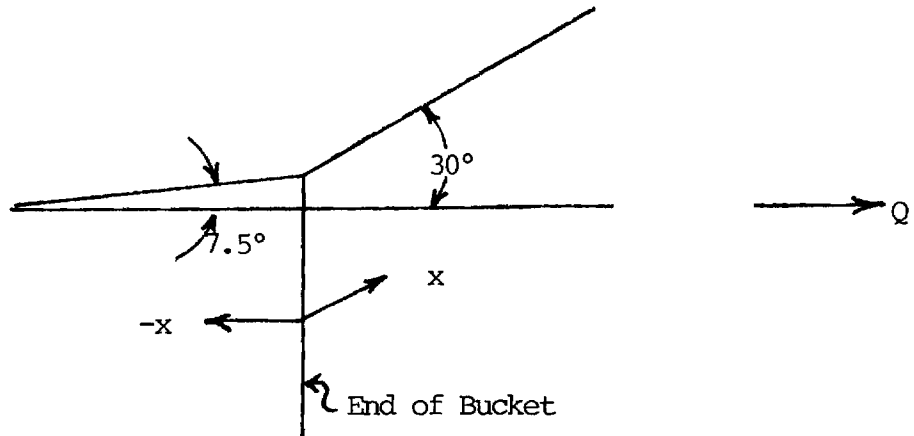

x-feet	NORTH		SOUTH	
	Inside	Outside	Inside	Outside
-50	650	667	648	667
-33	652	668	652	667
-17	654	668	653	667
0	661	668	660	667
17	664	668	663	667
33	663	668	664	667
50	665	667	666	667
67	665	667	666	667
83	666	667	666	667

Comments:

Water Surface Elevations in ft. (MSL)
 Top of Wall at 667 ft.
 Q = 60,000 cfs.
 Reservoir Elevation = 718 ft.
 Tailwater Elevation = 667 ft.

ROCKY MOUNTAIN PROJECT
 LOWER RESERVOIR MAIN SPILLWAY
 1:40 Scale Hydraulic Model

Table 74. Flip Bucket Type Energy Dissipator Water Surface Elevations

x-feet	NORTH				SOUTH			
	Inside		Outside		Inside		Outside	
	Vel., fps.	W.S., ft.	Vel., fps.	W.S., ft.	Vel., fps.	W.S., ft.	Vel., fps.	W.S., ft.
-50	N/A	646	N/A	N/A	N/A	646	N/A	N/A
-33	N/A	649	N/A	N/A	N/A	650	N/A	N/A
-17	N/A	655	N/A	N/A	N/A	654	N/A	N/A
0	N/A	659	N/A	662	N/A	658	N/A	N/A
17	7	659	N/A	662	3	659	N/A	N/A
33	7	660	N/A	662	6	659	N/A	N/A
50	5	660	N/A	662	5	660	N/A	N/A
67	4	660	0	662	5	660	N/A	N/A
83	6	660	0	662	5	661	N/A	N/A
100	6	661	1	662	4	661	N/A	N/A
117	4	661	1	662	5	662	N/A	N/A
133	2	661	1	662	3	662	N/A	N/A

Comments:

Q = 30,000 cfs.
 G.O. = ungated
 Reservoir Elevation = 708 ft.
 Tailwater Elevation = 661 ft.
 2 ft. waves at banks - 5 ft. waves at wingwalls
 Light steady splash over North wingwall
 Light intermittent splash over South wingwall
 Velocities at 20 ft. inside wingwall

ROCKY MOUNTAIN PROJECT
 LOWER RESERVOIR MAIN SPILLWAY
 1:40 Scale Hydraulic Model

Table 75. Flip Bucket Type Energy Dissipator Water Surface Elevations

x-feet	NORTH				SOUTH			
	Inside Vel., fps.	W.S., ft.	Outside Vel., fps.	W.S., ft.	Inside Vel., fps.	W.S., ft.	Outside Vel., fps.	W.S., ft.
-50	N/A	643	N/A	N/A	N/A	645	N/A	N/A
-33	N/A	648	N/A	N/A	N/A	649	N/A	N/A
-17	N/A	652	N/A	N/A	N/A	655	N/A	N/A
0	-7	657	N/A	N/A	-6	659	N/A	N/A
17	-8	658	N/A	662	-4	661	N/A	662
33	-10	660	1	662	-4	660	N/A	662
50	-5	660	2	662	-3	661	N/A	662
67	8	660	3	662	-4	661	N/A	662
83	5	661	3	662	-6	662	-1	662
100	6	661	3	662	-7	661	-2	662
117	7	661	3	662	-7	661	-4	662
133	8	662	3	662	-5	662	-7	662

Comments:

Q = 35,000 cfs.

G.O. = 15 ft. - all gates

Reservoir Elevation = 714 ft.

Tailwater Elevation = 662 ft.

2-3 ft. waves at banks - 10-12 ft. waves at wingwalls.

Light, but regular splash-over on the North wall.

Very light random splash-over on the South wall.

Moderate benching on both banks.

Extending North wall does not offer substantial improvement of benching effect or return flow.

Velocity taken 15 ft. inside wingwall.

ROCKY MOUNTAIN PROJECT
 LOWER RESERVOIR MAIN SPILLWAY
 1:40 Scale Hydraulic Model

Table 76. Flip Bucket Type Energy Dissipator Water Surface Elevations

x-feet	NORTH				SOUTH			
	Inside		Outside		Inside		Outside	
	Vel., fps.	W.S., ft.	Vel., fps.	W.S., ft.	Vel., fps.	W.S., ft.	Vel., fps.	W.S., ft.
-50	N/A	645	N/A	N/A	N/A	646	N/A	N/A
-33	N/A	647	N/A	N/A	N/A	647	N/A	N/A
-17	N/A	652	N/A	N/A	N/A	653	N/A	N/A
0	10	659	N/A	664	-4	660	N/A	N/A
17	6	659	N/A	664	-3	660	N/A	N/A
33	5	660	N/A	664	-3	660	N/A	N/A
50	-4	661	N/A	664	-3	660	N/A	N/A
67	-5	661	1	664	-6	661	N/A	N/A
83	-7	661	1	664	-6	661	N/A	N/A
100	-4	662	1	664	-7	662	N/A	N/A
117	-4	662	2	664	-8	663	N/A	N/A
133	-7	662	2	664	-6	663	2	N/A

Comments:

Q = 45,000 cfs.

G.O. = ungated

Reservoir Elevation = 713 ft.

Tailwater Elevation = 664 ft.

2-3 ft. waves at banks - 5-10 ft. waves at wingwalls

Splash over on North wall is steadier and heavier than for 30,000 cfs.

Splash over on South wall is light, but steady.

Scour beginning to appear at the end of the South wall but, is worse on the end of the North wall.

Considerable undermining of extended piece (133 ft.).

Return flow is noticed on both banks - worse on the North bank.

Extending North wall appears to help, but did not stop return flow.

Velocity at 15 ft. inside wingwall

ROCKY MOUNTAIN PROJECT
 LOWER RESERVOIR MAIN SPILLWAY
 1:40 Scale Hydraulic Model

Table 77. Flip Bucket Type Energy Dissipator Water Surface Elevations

x-feet	NORTH				SOUTH			
	Inside		Outside		Inside		Outside	
	Vel., fps.	W.S., ft.	Vel., fps.	W.S., ft.	Vel., fps.	W.S., ft.	Vel., fps.	W.S., ft.
-50	N/A	645	N/A	668	N/A	649	N/A	N/A
-33	N/A	651	N/A	668	N/A	651	N/A	N/A
-17	N/A	653	N/A	668	N/A	653	N/A	N/A
0	-10	660	N.F.	668	-8	658	N/A	N/A
17	-11	663	N.F.	668	-4	663	N/A	668
33	-9	663	N.F.	668	-4	664	N/A	668
50	-6	664	2	668	-5	663	N/A	668
67	-6	663	3	668	-6	665	N/A	668
83	-8	664	3	667	-6	664	N/A	668
100	-6	665	4	667	-6	667	N/A	668
117	-7	666	5	667	-8	666	-2	668
133	-6	665	N/A	667	-8	666	N/A	668

Comments:

Q = 60,000 cfs.

G.O. = ungated

Reservoir Elevation = 720 ft.

Tailwater Elevation = 667 ft.

3-4 ft. waves at bank - 10-12 ft. waves at wingwalls

Water runs over both walls into the spillway with splash over on both walls.

Scour at the end and behind both walls.

Strong return flow at both banks.

Velocities at 15 ft. inside wingwall

ROCKY MOUNTAIN PROJECT
 LOWER RESERVOIR MAIN SPILLWAY
 1:40 Scale Hydraulic Model

Table 78. Tailrace Velocity Survey

STATION	a	b	c	d	e	f	g
0	4	13	4	-2	N/A	N/A	N/A
1	6	14	3	-2	-1	N/A	N/A
2	6	9	3	-1	-1	N/A	N/A
3	6	9	4	-1	-2	N/A	N/A
4	6	7	6	-1	N/A	N/A	N/A
5	5	6	5	-2	N/A	N/A	N/A
6	2	5	4	3	0	N/A	N/A
7	N/A	3	5	4	2	N/A	N/A
8	N/A	4	4	4	3	2	0
9	N/A	2	3	3	3	3	0

COMMENTS:

Measurements taken at elev. 653 ft.
 Tailwater Elevation = 659 ft.
 Reservoir Elevation = 755 ft.
 Q = 20,000 cfs.
 Splash - none
 Erosion - none
 Waves - at bank 2-3 ft.
 at wingwall 5 ft.
 Jump - end of bucket
 Vortices - return flow just inside each wingwall
 return flow on north bank

See Definition Sketch, Figure 80.

ROCKY MOUNTAIN PROJECT
 LOWER RESERVOIR MAIN SPILLWAY
 1:40 Scale Hydraulic Model

Table 79. Tailrace Velocity Survey

STATION	a	b	c	d	e	f	g
0	6	20	6	3	-1	N/A	N/A
1	9	18	4	-3	-3	N/A	N/A
2	12	14	6	1	-1	N/A	N/A
3	9	14	6	1	-3	N/A	N/A
4	9	9	7	1	N/A	N/A	N/A
5	9	11	8	1	N/A	N/A	N/A
6	4	9	6	3	1	N/A	N/A
7	N/A	8	7	4	1	N/A	N/A
8	N/A	6	7	6	3	1	0
9	N/A	5	5	5	3	1	0

COMMENTS:

Measurements taken at elev. 657 ft.

Tailwater Elevation = 661 ft.

Reservoir Elevation = 759 ft.

Q = 30,000 cfs.

Splash - light, intermittent splash

Erosion - benches forming on both north and south banks

Waves - at bank 3-5 ft.

at wingwall 5-10 ft.

Jump - end of bucket

Vortices - return flow just inside each wingwall and along north bank

See Definition Sketch, Figure 80.

ROCKY MOUNTAIN PROJECT
 LOWER RESERVOIR MAIN SPILLWAY
 1:40 Scale Hydraulic Model

Table 80. Tailrace Velocity Survey

STATION	a	b	c	d	e	f	g
0	4	32	9	-3	-1	N/A	N/A
1	11	22	6	-3	-3	N/A	N/A
2	15	22	8	-3	-3	N/A	N/A
3	13	18	11	4	-3	N/A	N/A
4	11	15	11	3	N/A	N/A	N/A
5	8	11	9	6	-3	N/A	N/A
6	9	10	8	5	1	N/A	N/A
7	3	8	8	5	3	N/A	N/A
8	N/A	8	8	6	4	3	0
9	N/A	6	6	6	4	3	3

COMMENTS:

Measurements taken at elev. 658 ft.

Tailwater Elevation = 664 ft.

Reservoir Elevation = 764 ft.

Q = 45,000 cfs.

Splash - light, steady splash over both walls

Erosion - at end of north wingwall, but did not undermine; benching at both banks

Waves - at bank 3-5 ft.
 at wingwall 10 ft.

Jump - end of bucket

Vortices - Return flow mostly on south wall (inside) and strong return on north bank.

See Definition Sketch, Figure 80.

ROCKY MOUNTAIN PROJECT
 LOWER RESERVOIR MAIN SPILLWAY
 1:40 Scale Hydraulic Model

Table 81. Tailrace Velocity Survey

STATION	a	b	c	d	e	f	g
0	-5	37	9	-6	7	N/A	N/A
1	-4	25	11	3	-3	N/A	N/A
2	8	22	12	7	-3	N/A	N/A
3	9	18	16	10	-3	N/A	N/A
4	8	15	13	8	3	N/A	N/A
5	7	15	13	8	8	N/A	N/A
6	8	14	11	6	5	N/A	N/A
7	1	9	8	6	6	N/A	N/A
8	N/A	6	9	6	6	3	1
9	N/A	6	9	6	5	4	1

COMMENTS:

Measurements taken at elev. 659 ft.

Tailwater Elevation = 667 ft.

Reservoir Elevation = 769 ft.

Q = 60,000 cfs.

Splash - heavy, steady splash over both wingwalls

Erosion - Shoal has washed down to Station 6

Benching on both banks (except for heavier rock section)

Deep undermining on north wingwall

Waves - at bank 5 ft.

at wingwall 10-12 ft.

Jump - just off end of bucket

Vortices - strong return flow inside both wingwalls, and along north bank.

See Definition Sketch, Figure 80.