

GEORGIA INSTITUTE OF TECHNOLOGY
Engineering Experiment Station

PROJECT TERMINATION

Date 12/4/70

PROJECT TITLE: Human Acceleration Study
PROJECT NO: A-1216
PROJECT DIRECTOR: Dr. W. L. Bloom w/Assoc. Proj. Dir.'s: Mr. J. D. Walton, Jr.
SPONSOR: Office of Naval Research Prof. W. H. Horton
TERMINATION EFFECTIVE: November 5, 1970*
CHARGES SHOULD CLEAR ACCOUNTING BY: November 30, 1970**

*Date Final Report submitted.

**Contract expired on 9/30/70; subcontract w/Emory on 8/31/70.

Contract Closing Items Remaining: Final Invoice & Closing Documents.
Final Report of Inventions.
Incorporation of Overhead Rate.

Office of the Director

COPIES TO:

Project Director & Assoc. Proj. Dir.'s (2)
Director
Associate Director
Assistant Directors
Division Chief Dean W. O. Carlson
Branch Head Dr. A. L. Ducoffe
Accounting
Engineering Design Services

General Office Services
Photographic Laboratory
Purchasing
Report Section
Library ✓
Security
Rich Electronic Computer Center

GEORGIA INSTITUTE OF TECHNOLOGY

ATLANTA, GEORGIA 30332

OFFICE OF
THE VICE PRESIDENT
FOR ACADEMIC AFFAIRS

January 7, 1970

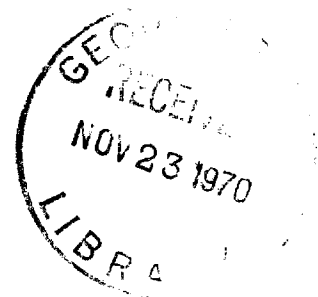

Office of Naval Research
Department of the Navy
Washington, D. C. 20360

Attention: Code 444
Director, Medicine and Dentistry Branch
Biological Sciences Division

Subject: Contract No. N00014-67-A-0159-0006, Monthly Status
Report No. 1 for period 1 December - 31 December,
1969 (Georgia Tech Project No. A-1216)

Gentlemen:

Work during the current report period was limited to organization of the project and acquainting the Georgia Tech and Emory University project personnel with the state-of-the-art of acceleration research in bioengineering.

On December 5 and 9, Captain Channing Ewing visited Georgia Tech for the purpose of reviewing his research program on the human dynamics response to impact acceleration. His discussions were accompanied by 16-mm motion pictures and 35-mm slides. These materials were left at Georgia Tech for use in discussions with the faculty and staff concerning the use of the acceleration facility. On December 9, Captain Ewing visited the Yerkes Primate Center to determine the use potential of this facility for an acceleration program.

Work during the next period will concentrate on two areas: (1) becoming familiar with available acceleration devices and determining their capability for providing the desired onset acceleration rates, and (2) conducting preliminary conferences

Monthly Status Report No. 1
Contract No. N00014-67-A-0159-0006

2

with personnel of those schools and departments at Georgia Tech and Emory University which would be expected to be principal participants in the use and operation of an acceleration facility.

Very truly yours,

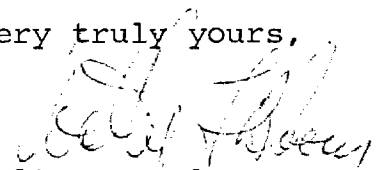
Walter L. Bloom, M.D.
Principal Investigator

Addressee: In quadruplicate

bcc: Mr. J. D. Walton
Professor W. H. Horton
Captain Channing Ewing
Dr. Daniel J. Thomas
Office of Research Administration (2)✓

GEORGIA INSTITUTE OF TECHNOLOGY

ATLANTA, GEORGIA 30332

OFFICE OF
THE VICE PRESIDENT
FOR ACADEMIC AFFAIRS

February 11, 1970



Office of Naval Research
Department of the Navy
Washington, D.C. 20360

Attention: Code 444
Director, Medicine and Dentistry Branch
Biological Sciences Division

Subject: Contract No. N00014-67-A-0159-0006, Monthly Status
Report No. 2 for the period 1 January - 31 January

Gentlemen:

Work during the current report period was conducted as follows:

1. Dr. Chyatte conducted preliminary conferences with the Chairman of the Department of Anatomy and the Chairman of the Department of Medicine at the Emory University School of Medicine and with the Director of the Yerkes Primate Research Center.

2. A visit was made by Professor Horton to the Monterey Research Laboratory, Inc. to obtain information on linear accelerators. The results of that visit are as follows:

During the period being reported, information with regard to the nature of and location of existing sled facilities was gathered. Some 70 references to research already undertaken, relative to the various technical problems involved, were located and are currently under review. Discussions were held with Monterey Research, Inc., Monterey, California, and it was established that this organization already supplied various crash simulators. However, in general, these devices did not conform to the basic requirement as defined by Captain C. L. Ewing. However, this company appears very capable

and they indicated that they could provide a machine which would satisfy, in part, the needs of the research program. This machine would be capable of generating the following specified trapezoidal acceleration pulses:

<u>Peak G Level</u>	<u>Dwell Duration(s)</u>	<u>Onset and Decay Date(s)</u>
1-3	100 ms	200-600 g/sec (5 ms risetime min)
4	100 ms	200-600 g/sec
5	100 ms	200-800 g/sec
10	50 ms	400-2000 g/sec
12	50 ms	600-2000 g/sec
14	50 ms	600-2800 g/sec
16	50 ms	1000-3200 g/sec
18	50 ms	1200-3600 g/sec

The machine would be well within the state of the art and would employ well-proven components and would cost between \$60,000 and \$80,000.

A description of the device follows.

1. Basic Machine

The machine consists of a pair of 3-inch diameter, chrome-plated guide rods on which the Single Occupant Sled is mounted. Another sled, weighing approximately the same as the Single Occupant Sled plus test subject (750 pounds total), is also mounted on the guide rails. This second sled, or Impact Sled, is accelerated at the Single Occupant Sled by a large Velocity Generator mounted on a load spreader which is attached to the foundation. Shock pulse forming programmers are mounted between the Impact Sled and the Single Occupant Sled. The Single Occupant Sled is initially at rest, has energy transferred to it from the Impact Sled, with pulse parameters being controlled by the programmers.

2. Programmers

The shock programmers act as springs with adjustable force-vs-deflection characteristics. The force-vs-deflection characteristic controls the shape, amplitude, and duration of the shock pulse. Two cylinders are used in series, one to control the onset and decay rate and one to control the dwell acceleration level. The programmers are adjusted entirely from the control console and no disassembly of any kind is required to obtain various shock pulses.

a. Onset Rate Programmer

Onset rate is controlled by an Opposing Force Gas Cylinder. This cylinder consists of two gas springs, one on the left side of the piston, and one on the right side of the piston. These two springs oppose or "buck" each other. Each of the springs has a non-linear force-vs-deflection characteristic because of the adiabatic compression and expansion of the gases. These non-linearities can be made to cancel each other in various ways by simply changing the two charge pressures, thus linear onset rates can be controlled over a wide range.

b. Dwell Acceleration Level Programmer

Dwell acceleration level is controlled by a constant force gas cylinder. The cylinder precharge pressure controls the force and, therefore, the acceleration level at which the cylinder operates. Thus, acceleration level can be varied over a wide range.

3. Operation

Prior to running the test, the Impact Sled is positioned so that it is in contact with the Velocity Generator piston rod. The Single Occupant Sled is positioned so that there is a space of approximately 1 to 2 feet between the two programmers. The programmers are precharged on the basis of the shock pulse which is to be generated with information obtained from the operating manual. The

Velocity Generator is then charged pneumatically and hydraulically. When the hydraulic pressure reaches the level required for the test to be performed, the Velocity Generator is fired. This accelerates the Impact Sled up to the required velocity and the two programmers impact, generating the required shock pulse. Since the mass of the Impact Sled is approximately equal to that of the Single Occupant Sled, and because of the highly resilient programmers, the Impact Sled velocity, after the shock pulse, is approximately zero. During the shock pulse, the Single Occupant Sled has been accelerated to approximately the same velocity which the Impact Sled had. The Single Occupant Sled is then slowed down and stopped by its brake system. After the test has been completed, the sleds are returned to their original positions. If an identical test is to be run, all precharge pressures are left at the same level; only the Velocity Generator need be recharged hydraulically. A different shock pulse may be generated by changing the precharge pressures in the programmers or by changing the hydraulic charge pressure in the Velocity Generator. The procedure for doing this will be outlined in the manual furnished with the machine.

4. Advantages of this System

a. A major advantage of this system is the great versatility of the shock programmers allowing wide variations of operating parameters. These programmers are very repeatable and highly predictable.

b. Since the programmers do not have to be disassembled to obtain any of the specified pulses, a high repetition rate with increasing velocities is possible. This repetition rate is further increased because the programmers do not exhaust their stored nitrogen to the atmosphere during shock pulses.

Additionally, contact was made with the Naval staff at Philadelphia, who deal with aircraft launch equipment, etc., and arrangements have been made to discuss with them the characteristics of the available steam catapults.

It seems likely, at the present time, that, if such a device were used as the large Velocity Generator in a scheme very similar

to that proposed by Monterey Research, the basic requirements defined by Captain C. N. Ewing could be more nearly met.

Work for the next period will be continued in the areas outlined in Monthly Status Report No. 1. In addition, it is anticipated that trips will be made to the Naval Aeronautical Engineering Laboratory in Philadelphia and to the Aerospace Crew Equipment Department at NADC, Johnsville, Pennsylvania.

Sincerely,

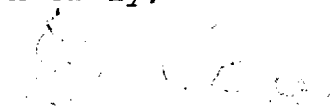
Walter L. Bloom, M.D.
Principal Investigator

WLB/mv

Addressee: In quadruplicate

GEORGIA INSTITUTE OF TECHNOLOGY

ATLANTA, GEORGIA 30332

OFFICE OF
THE VICE PRESIDENT
FOR ACADEMIC AFFAIRS

March 17, 1970



Office of Naval Research
Department of the Navy
Washington, D.C. 20360

Attention: Code 444
Director, Medicine and Dentistry Branch
Biological Sciences Division

Subject: Contract No. N00014-67-A-0159-0006, Monthly Status
Report No. 3 for the period 1 February - 28 February,
1970 (Georgia Tech Project No. A-1216)

Gentlemen:

Work during the current report period was conducted as follows:

1. On February 11th, a briefing was held with those members of the Georgia Tech faculty who were instrumental in the decision to undertake this study. The purpose of this briefing was to review the status of the program and to discuss a preliminary outline of the subject matter of the study. A copy of the outline is attached.

2. Contacts were made with all Schools, Departments, and Divisions of Georgia Tech for the purpose of obtaining a representative to participate in this study. With the exception of the School of Mathematics and the Department of Social Sciences, all units of Georgia Tech will be represented in this study.

3. Briefings were organized for March 10th and 11th for the purpose of introducing the Georgia Tech representatives identified above to the objectives of this study. A slide and motion picture presentation has been prepared for this briefing.

Work for the next period will continue as outlined previously. It is anticipated that the March 10th and 11th briefings will identify those units of Georgia Tech which will be major participants in the acceleration study. It may then be advisable to request a briefing of these participants by Captain Ewing in the specific aims and objectives of an acceleration facility envisioned in this study in order that each unit might better define its possible participation in the programs which will be carried out in such a facility. At this time, it appears that late March or early April would be appropriate for the briefing. In the meantime, campus-wide contacts will be initiated at Emory following the procedures used at Georgia Tech.

During the period being reported, a visit was made to the Naval facility at Philadelphia. Much valuable information relevant to the installation, use, and characteristics of steam catapults was obtained. This information is now being digested and an effort made to determine the best method to adapt the device to a sled which will comply with the Navy's specific requirements.

Sincerely,

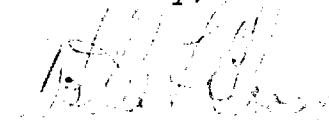

Walter L. Bloom, M.D.
Principal Investigator

WLB/mv

Addressee: In quadruplicate

AN ENGINEERING STUDY OF THE REQUIREMENTS FOR AN ACCELERATION FACILITY
FOR BIO-ENGINEERING RESEARCH AND THE FEASIBILITY
OF ESTABLISHING SUCH IN THE ATLANTA AREA

I. THE ACCELERATOR (GEORGIA TECH) - PROF. HORTON

- A. Requirements
- B. Availability
- C. Performance
 - 1. Capabilities
 - 2. Limitations
- D. Costs/Performance
 - 1. Installation
 - 2. Operation
 - 3. Staffing
 - 4. Scheduling
- E. Location/Performance



II. ACCELERATOR SUBJECT

Objective of Navy-Army Program:

Develop model of living human dynamic response to impact acceleration by:

- 1. determining response of living human to low/medium impact acceleration
- 2. determining response of living primate to low/medium/high acceleration
- 3. correlation of 1 and 2 to predict human tolerance to high impact acceleration

and to develop safety devices/systems to protect living subject in high impact acceleration environments

A. Biological

- 1. Human (Naval Aerospace Medical Institute)
 - a. Cadaver
 - (1) Storage
 - (2) Handling
 - (3) Monitoring
 - (4) Anatomy
 - b. Live
 - (1) Transportation
 - (2) Housing
 - (3) Examination
 - (a) Pre-acceleration
 - (b) Post-acceleration
- 2. Non-Human (Yerkes)
 - a. Primate
 - b. Other

- B. Non-biological (Georgia Tech)
 - 1. Instruments
 - a. Recorders
 - b. Transducers
 - c. Telemetry devices
 - d. Other
 - 2. Mechanical devices
 - 3. Other

III. EDUCATION/RESEARCH/SERVICE OPPORTUNITIES

- A. Engineering (Georgia Tech)
 - 1. Sled/Accelerator
 - a. Mechanical
 - (1) System Design
 - (2) Propulsion Systems
 - (3) Structure Dynamics
 - b. Electrical
 - (1) Controls
 - (2) Response Measurements
 - (3) Telemetry
 - 2. Sled/Subject
 - a. Mechanical
 - (1) Sled-subject interaction
 - (2) Subject-accelerometer interaction
 - (3) Other
 - b. Electrical
 - (1) Transducers
 - (2) Subject response measurements
 - (3) Telemetry
 - (4) Data display
 - (5) Data reduction
 - (6) Other
 - 3. Bioengineering
 - a. Modeling of Human Dynamic Response to Acceleration
 - b. Fluid dynamics
 - c. Neuromuscular response
 - d. Skeletal response
 - e. Other
 - 4. Related Engineering Output
 - a. Transportation safety
 - (1) Highway design
 - (2) Airport design
 - (3) Vehicle design
 - (4) Passenger safety devices
 - (a) restraint systems
 - (b) protective helmets
 - (c) other
 - (5) Dummy design/analysis
 - (6) Other

- b. Artificial organs
 - (1) bone substitutes
 - (2) other
- 5. Medical Requirements (Emory) - Dr. Chyatte

IV. ACCELERATION FACILITY (FACILITIES)

- A. Location(s) (Land)
- B. Number and Type of Accelerators
 - 1. Linear
 - 2. Rotary
 - 3. Non-Linear/Non-Rotary
- C. Applications
 - 1. Engineering
 - 2. Medical
 - 3. Bioengineering
 - 4. Other
- D. Support
 - 1. Personnel
 - a. Engineering
 - b. Medical
 - c. Service
 - 2. Facilities
 - a. Shop
 - (1) mechanical
 - (2) electrical
 - (3) other
 - b. Medical (human/non-human)
 - (1) first aid
 - (2) examination
 - (3) x-ray
 - (4) housing
 - (5) other
- E. Building and Physical Plant
- F. Administration
 - 1. Facility Operation
 - 2. Contracts
 - 3. Leasing
 - 4. Service
 - 5. Scheduling

V. RECOMMENDATIONS

- A. For Navy's Program (DoD)
- B. For Transportation (DoT)
- C. For Georgia Tech/Emory Programs
- D. For Bioengineering Center
- E. For Future Development/Expansion

GEORGIA INSTITUTE OF TECHNOLOGY

ATLANTA, GEORGIA 30332

OFFICE OF
THE VICE PRESIDENT
FOR ACADEMIC AFFAIRS

April 2, 1970



Office of Naval Research
Department of the Navy
Washington, D.C. 20360

Attention: Code 444
Director, Medicine and Dentistry Branch
Biological Sciences Division

Subject: Contract No. N00014-67-A-0159-0006, Monthly Status
Report No. 4 for the period 1 March - 31 March 1970
(Georgia Tech Project No. A-1216)

Gentlemen:

1. On March 10th and 11th, briefings were held for representatives of all schools and departments of Georgia Tech. The objectives of the study were discussed and each representative was given a questionnaire to complete and return in April. The questionnaire was designed to obtain information concerning the specific interests of each department in accelerator related research and development.

2. A briefing is being scheduled for the staff of Yerkes Primate Center on April 3rd. Briefings for the Emory campus will be scheduled later in April.

3. On April 9th, Mr. Walton will visit representatives of the Army, Navy, and Department of Transportation to become acquainted with the people in those departments who are interested in acceleration research.

4. Mr. Walton and Dr. Chyatte will visit the Philadelphia Navy Base on April 10, 1970, to discuss acceleration research with Mr. Moses Siegel and Mr. Marvin Schulman and to witness a test firing of an acceleration research sled.

5. The week of April 20th has been tentatively selected as a date for Captain Ewing's visit to Georgia Tech to discuss specific aims and objectives of the Navy's acceleration research program.

Sincerely,

Walter L. Bloom, M.D.
Principal Investigator

WLB/mv

Addressee: In quadruplicate

GEORGIA INSTITUTE OF TECHNOLOGY
ATLANTA, GEORGIA 30332

A-1216

OFFICE OF
THE VICE PRESIDENT
FOR ACADEMIC AFFAIRS

May 8, 1970

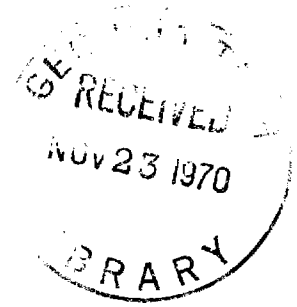

Office of Naval Research
Department of the Navy
Washington, D.C. 20360

Attention: Code 444
Director, Medicine and Dentistry Branch
Biological Sciences Division

Subject: Contract No. N00014-67-A-0159-0006, Monthly Status Report
No. 5 for the period 1 April - 30 April, 1970 (Georgia
Tech Project No. A-1216

Gentlemen:

Work during the current report period was conducted as follows:

1. On April 9th, Mr. Walton visited Lt. Col. D. T. Sanders, U.S. Army Medical Research and Development Command; Commander Paul E. Tyler, U.S. Navy Bureau of Medicine and Surgery, and Mr. Robert L. Carter, National Highway Safety Bureau in Washington, D.C. These visits were made for the purpose of becoming familiar with the activities of these organizations and to determine their interests in impact acceleration research.

2. On April 10th, Dr. Chyatte, Emory University, Professor Warner, Yerkes Primate Center, and Mr. Walton visited the Naval Air Engineering Center, Naval Base, Philadelphia, Pennsylvania. A meeting was held with Mr. Moses Siegel and Mr. Allan Honigman for the purpose of discussing acceleration devices in general and steam catapults, in particular. A meeting was also held with Mr. Marvin Schulman who described his impact acceleration facility in detail and allowed us to witness a test firing of accelerator which was being used to evaluate a particular energy absorbing device.

3. On April 23-24, Captain Channing Ewing visited Georgia Tech and Emory University for the purpose of discussing with interested faculty and staff specific aims and objectives of the Army-Navy impact acceleration program. April 23rd was spent in discussing the engineering aspects of the program with Georgia Tech faculty and staff. A meeting was held on April 24th with scientists of the Yerkes Primate Center to consider the use of primates in the proposed acceleration work. The afternoon of April 24th was spent with representatives of the Emory University Medical School to discuss the medical aims of the Army-Navy Program.

Monthly Status Report No. 5
Page 2

With regard to the engineering feasibility, the studies are completed and show that a facility which completely satisfies the Navy specifications is technically feasible and economically reasonable.

Very truly yours,

Original Signed

By W. L. BLOOM

Walter L. Bloom, M.D.
Principal Investigator

WLB/mv

Addressee: In quadruplicate

GEORGIA INSTITUTE OF TECHNOLOGY

ATLANTA, GEORGIA 30332

OFFICE OF
THE VICE PRESIDENT
FOR ACADEMIC AFFAIRS

June 3, 1970

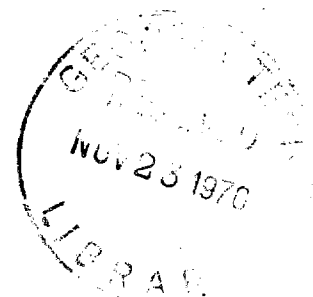

Office of Naval Research
Department of the Navy
Washington, D. C. 20360

Attention: Code 444
Director, Medicine and Dentistry Branch
Biological Sciences Division

Subject: Contract No. N00014-67-A-0159-0006, Monthly
Status Report No. 6 for the period 1 May -
31 May 1970 (Georgia Tech Project No. A-1216)

Gentlemen:

Work during the current report period was conducted
as follows:

1. On 1 May 1970 Professor Warner of Yerkes Primate Center visited the 6571st Aeromedical Research Laboratory at Holloman Air Force Base, New Mexico. The primary purpose of this visit was to become familiar with the procedures used in handling chimpanzees for impact acceleration studies. A secondary purpose was to visit the Daisy Decelerator and discuss the use of this facility for impact acceleration research. Those people visited were C. D. Gragg, Chief of Engineering, and Robert Godby, engineer, Aeromedical Research Laboratory; Edwin M. Trout, biomedical instrumentation engineer and William H. Muzzy, mechanical engineer, Dynalectric Corporation. From this visit it was learned that no decision would be made concerning the disposition or release of chimpanzees until 16 September 1970. It was also learned that all chimpanzees used on the Daisy Decelerator were subjected only to the levels of acceleration anticipated for human subjects, were trained for the experiments, and were not anesthetized when subjected to impact acceleration.

2. On 29 May a meeting was held at Yerkes Primate Center to discuss the organization of the final report. It was agreed that the basic information needed for this report had been assembled and that future activities should be directed toward completing this report as soon as possible.

Work during the next report period will be concentrated on preparing the draft of the final report. Summary reports from Professor Warner, Dr. Chyatte, Professor Horton, and Mr. Walton will be prepared by 19 June 1970. These reports will then be combined into a final draft to be completed by 6 July. It is tentatively planned that a meeting will be held with Captain Ewing and Dr. Callahan at Georgia Tech during the week of 5 July for the purpose of reviewing the results of the study and the draft of the final report.

Very truly yours,

Walter L. Bloom, M.D.
Principal Investigator

WLB:gs

Addressee: In quadruplicate

GEORGIA INSTITUTE OF TECHNOLOGY

ATLANTA, GEORGIA 30332

July 2, 1970



Office of Naval Research
Department of the Navy
Washington, D. C. 20360

Attention: Code 444
Director, Medicine and Dentistry Branch
Biological Sciences Division

Subject: Contract No. N00014-67-A-0159-0006, Monthly Status Report
No. 7 for the period 1 June - 30 June 1970 (Georgia Tech
Project No. A-1216)

Gentlemen:

Work during the current report period was concerned with concluding the study and organizing the material for the final report. Particular attention was given to identifying possible locations for the accelerator.

A meeting has been scheduled for Captain Ewing to confer with representatives of the Animal Resources Board at Yerkes Primate Center on 14 July. The purpose of this meeting is to obtain approval of the ARB to use chimpanzees for impact acceleration studies.

The draft of the final report will be completed during the next report period.

Very truly yours,

A handwritten signature in cursive script, which appears to read "Walter L. Bloom, M.D.", is written over the typed name.

Walter L. Bloom, M.D. *for*
Principal Investigator

WLB/jw

Addressee: In quadruplicate

GEORGIA INSTITUTE OF TECHNOLOGY

ATLANTA, GEORGIA 30332

OFFICE OF
THE VICE PRESIDENT
FOR ACADEMIC AFFAIRS

September 10, 1970



Office of Naval Research
Department of the Navy
Washington, D. C. 20360

Attention: Code 444
Director, Medicine and Dentistry Branch
Biological Sciences Division

Subject: Contract No. N00014-67-A-0159-0006, Monthly
Status Reports No. 8 and 9 for the period 1
July - 31 August 1970 (Georgia Tech Project
No. A-1216)

Gentlemen:

On July 14th a meeting was held at the Yerkes Primate Center for the purpose of obtaining approval of the Animal Resources Board to use chimpanzees in impact acceleration studies. Captain Channing Ewing reviewed the Navy's impact acceleration program and outlined the future plans for this program and the role that chimpanzees would play in accomplishing objectives of the Navy. This meeting proved successful and permission was given to Yerkes to use chimpanzees in impact acceleration research.

Following this meeting representatives of Yerkes visited the Daisy Track at Holloman Air Force Base, New Mexico to determine the status of the chimpanzee colony. It was learned that the track will be kept open until 1 January 1971 and that chimpanzees would not be available before that date. No decision was made as to whether or not chimpanzees would be available after 1 January.

Office of Naval Research
Page 2
September 10, 1970

The remainder of this period was spent in preparing the final report. This report will be submitted in October.

Very truly yours,

A handwritten signature in cursive script, appearing to read "Walter L. Bloom".

Walter L. Bloom, M.D.
Principal Investigator

WLB:gs

Addressee: In quadruplicate

AN ENGINEERING STUDY OF THE REQUIREMENTS FOR AN ACCELERATION FACILITY
FOR BIOENGINEERING RESEARCH AND THE FEASIBILITY OF
ESTABLISHING SUCH IN THE ATLANTA AREA

Final Report

September 1970



By

J. D. Walton, Jr. &
W. H. Horton
Georgia Institute of Technology

S. B. Chyatte, M.D., Emory University, School of Medicine
H. Warner, Emory University, Yerkes Regional Primate Research Center

Prepared for

Department of the Navy
Office of Naval Research
Biological Sciences Division
Medicine and Dentistry Branch

Under

Contract N00014-67-A-0159-0006

AN ENGINEERING STUDY OF THE REQUIREMENTS FOR AN ACCELERATION FACILITY
FOR BIOENGINEERING RESEARCH AND THE FEASIBILITY OF
ESTABLISHING SUCH IN THE ATLANTA AREA

Final Report

September 1970

By

J. D. Walton, Jr. &
W. H. Horton
Georgia Institute of Technology

S. B. Chyatte, M.D., Emory University, School of Medicine
H. Warner, Emory University, Yerkes Regional Primate Research Center

Prepared for

Department of the Navy
Office of Naval Research
Biological Sciences Division
Medicine and Dentistry Branch

Under

Contract N00014-67-A-0159-0006

TABLE OF CONTENTS

	Page
I. SUMMARY	1
II. OBJECTIVE	2
III. INTRODUCTION	3
IV. BACKGROUND	5
V. ORGANIZATION OF THE STUDY	7
VI. RESULTS	11
A. Georgia Tech	11
1. The Accelerator	11
2. Interests of the Georgia Tech Community in Impact Acceleration Research	14
3. Opportunities for Impact Acceleration Research at Georgia Tech.	19
a. Government	19
b. Industry	19
4. Contribution to Bioengineering	21
5. Contribution to Education.	22
B. Emory University	23
1. Medical School Departmental Interests.	23
2. Yerkes Regional Primate Research Center.	24
a. Animal Housing	24
b. Other Supporting Services.	25
c. Research Activities.	25

(Continued)

TABLE OF CONTENTS (Continued)

	Page
VII. PROPOSED PLANS FOR THE IMPACT ACCELERATION PROGRAM	26
A. The Navy's Program	26
B. A Plan for Georgia Tech's Program.	28
1. Test Subject	28
2. Accelerators	29
a. Commercial Unit.	29
b. Advanced Unit.	30
3. Location of the Facility	30
a. Commercial Unit.	31
b. Advanced Unit.	34
4. Supporting Facilities.	34
VIII. RECOMMENDATIONS.	36
REFERENCES.	37
APPENDIX I - GEORGIA TECH AEROSPACE ENGINEERING STUDY REPORT ON ADVANCED ACCELERATOR DESIGNS	
APPENDIX II - STUDY REPORT OF THE YERKES PRIMATE CENTER	
APPENDIX III - GEORGIA TECH SUPPORTING FACILITIES	

LIST OF TABLES

	Page
I. PRELIMINARY PROGRAM OUTLINE	9
II. LOW ACCELERATION REQUIREMENT.	12
III. HIGH ACCELERATION REQUIREMENT	13
IV. IMPACT ACCELERATION QUESTIONNAIRE	15
V. SUMMARY OF RESPONSES FROM GEORGIA INSTITUTE OF TECHNOLOGY TO IMPACT ACCELERATION QUESTIONNAIRE	16

LIST OF ILLUSTRATIONS

1. Schematic of Program to Determine Threshold of Human Injury from Impact Acceleration.	27
2. Georgia Tech Campus Showing Three Possible Locations for Commercial Accelerator.	32
3. Plan of Civil Engineering Laboratory.	33

I. SUMMARY

This study has revealed a definite interest in acceleration research at Georgia Tech and identified potential participants in the Navy's program to determine human dynamic response to impact acceleration. The program has been recognized as one which is in the area of bioengineering and would contribute to the development and growth of this area of major thrust at Georgia Tech. Research and educational opportunities have been determined and are found to be consistent with the mission of Georgia Tech.

Through the cooperative efforts of Emory University's Medical School and Yerkes Regional Primate Research Center, interinstitutional collaboration was realized in conducting this study. Potential participating departments at Emory University were identified and, in particular, the role of the Primate Center in the Navy's program was formulated. A plan for early acquisition and operation of a commercially available accelerator on the Georgia Tech campus was outlined, and a cooperative research effort with the Primate Center which would contribute to the Navy's impact acceleration program was suggested. Although the research effort thus described would advance the Navy's program to determine human dynamic response to impact acceleration, the accelerator would not be capable of providing all of the impact acceleration parameters specified by the Navy.

In the course of this study, the School of Aerospace Engineering developed a conceptual design for an accelerator which satisfies all of the Navy's specifications. Based on this development the A. E. School proposed a program to design and construct the accelerator and to undertake the operation of the facility.

II. OBJECTIVE

To determine the nature of an acceleration facility which will meet the needs of the Navy's impact injury program and to establish the feasibility of developing and operating such a facility in the Atlanta area.

III. INTRODUCTION

Modern vehicles of high thrust and maneuverability have introduced new problems in human tolerance to force due to acceleration. These forces can, and do, have a distinct effect upon the human operator, degrading both his physiological and psychological functioning. Even moderate amounts of acceleration can introduce significant disturbances into his performance of control functions.

But in considering the effects of acceleration, we are not only concerned with the magnitude, direction, and duration of acceleration exposure, there must also be detailed consideration given to the rate of onset. The total effect of the acceleration depends upon a combination of all these factors. It is known, for example, that large forces acting for short durations on soft body tissue set up shock waves which may result in lung damage, sensorial, and cerebral effects. The application of such force to the skeletal structure of the body may cause dislocation and bone fracture. Shock waves are absent if the acceleration is applied at relatively low magnitude for larger periods, but under these conditions serious physiological effects may result from the displacement of body organs or pooling of body fluids. Although much is known about such effects, much more remains to be discovered. It is clear that physiological response to impact acceleration is an important area of research, multidisciplinary research of interest to the academic community and of vital concern to the military services and civil authorities. It is an area in which there is a pressing need for advanced education.

This report reviews the results of a joint effort between the Georgia Institute of Technology, and Emory University's Medical School and Yerkes Regional Primate Research Center, to determine the nature of an acceleration

facility which will meet the needs of the Navy's impact injury program and to establish the feasibility of developing and operating such a facility in the Atlanta area.

IV. BACKGROUND

On October 31, 1968 representatives of the United States Navy visited the Georgia Institute of Technology for the purpose of discussing the Navy's requirements for an acceleration facility to study human dynamic response to impact acceleration. Such a facility was identified as a critical need in order to provide the quantitative data required to optimize the design of structures and restraint systems which would significantly reduce pilot casualties resulting from aircraft accidents. A recent study reported that, at the present time, there is no way to evaluate restraint system design because the data concerning human dynamic response to input acceleration is not known 1/. This situation exists because of the very complex, interdisciplinary nature of the research required to obtain the desired data. Therefore, the vast majority of investigating agencies have settled for grossly qualitative data related to a specific set of impact parameters.

The type of research envisioned by the Navy would require the very close collaboration of scientists and engineers from several different disciplines. In particular such an effort would require expertise in the physical and life sciences, in medicine and engineering. In addition there would be a need for expertise in the field of primate research. The fact that Georgia Tech and Emory University, including both its Medical School and the Yerkes Primate Center, are located in Atlanta, made this area a prime candidate for the possible location of an acceleration facility.

The initial contact by the Navy was made in order to determine the degree of Georgia Tech's interest in establishing and operating an impact acceleration facility and in participating in and coordinating acceleration research efforts with Emory University and Yerkes. It was the opinion of the Georgia Tech

representatives that this research should be of interest to the academic community. Also, the growing interest in bioengineering at Georgia Tech and Emory would suggest that such a cooperative research program would assist in the development of this field. Subsequent meetings with representatives from Emory University's Medical School and Primate Center determined similar interests at these institutions and a joint proposal was submitted to undertake this study, which was activated on December 1, 1969.

V. ORGANIZATION OF THE STUDY

Because of the complex nature of the research required to determine human dynamic response to impact acceleration, of the problems associated with designing and developing an advanced impact acceleration facility, and of the operation and utilization of such a facility, it was difficult always to keep in proper perspective the various interacting factors that were to be considered in this study. There was a tendency to think in terms of a fully established acceleration "center" which would provide the staff, facilities, and support equipment necessary to generate the data desired by all of the schools and departments that might be determined to have an interest in impact acceleration. Such a "center" is usually envisioned as providing a number of accelerators offering a wide range of operating parameters, occupying a new building, employing a large staff, and requiring a substantial physical plant and support. The operation would require a large and continuing research budget or substantial financial support from the State. Finally, from an institutional standpoint, the success of the "center" would depend upon an educational/research program based on the identified "interests" of faculty and staff of the participating institutions. Since the current faculty and staff are completely occupied with teaching and/or research which would not now be associated with impact acceleration, it would be difficult to differentiate between real education/research potential and casual interest on the part of the faculty or staff member. Therefore, throughout this study there was a concerted effort made to assure that any recommendations resulting from this study would be based on existing education/research activities of the faculty and staff, that the proposed acceleration facility would involve substantial institutional participation, and that the

operation of the accelerator would be consistent with the mission of Georgia Tech. In this connection, it was emphasized at the outset that Georgia Tech would not be interested merely in operating an acceleration facility for the Navy.

In order to accomplish the objectives of this study, a preliminary program outline was organized into four topical areas: 1) the accelerator, 2) the accelerator subject, 3) education, research, and service opportunities, and 4) acceleration facility. These areas together with the general subject matter considered in each area are shown in Table I. Using this preliminary outline, each of the participating institutions undertook an in-depth study to determine its own primary areas of participation, to identify education/research opportunities of interest to its faculty and staff, and to make recommendations concerning its involvement in the Navy's impact acceleration program.

TABLE I
PRELIMINARY PROGRAM OUTLINE

<p>I. THE ACCELERATOR</p> <p>A. Requirements</p> <p>B. Availability</p> <p>C. Performance</p> <ol style="list-style-type: none"> 1. Capabilities 2. Limitations <p>D. Costs/Performance</p> <ol style="list-style-type: none"> 1. Installation 2. Operation 3. Staffing 4. Scheduling <p>E. Location/Performance</p>	<p>III. EDUCATION/RESEARCH/SERVICE/ OPPORTUNITIES</p> <p>A. Engineering</p> <ol style="list-style-type: none"> 1. Sled Accelerator <ol style="list-style-type: none"> a. Mechanical <ol style="list-style-type: none"> (1) System Design (2) Propulsion System (3) Structure Dynamics b. Electrical <ol style="list-style-type: none"> (1) Controls (2) Response Measurements (3) Telemetry 2. Sled/Subject <ol style="list-style-type: none"> a. Mechanical <ol style="list-style-type: none"> (1) Sled-subject interaction (2) Subject-accelerometer interaction (3) Other b. Electrical <ol style="list-style-type: none"> (1) Transducers (2) Subject response measurements (3) Telemetry (4) Data display (5) Data reduction (6) Other 3. Related Engineering Output <ol style="list-style-type: none"> a. Transportation safety <ol style="list-style-type: none"> (1) Highway design (2) Airport design (3) Vehicle design (4) Passenger safety devices <ol style="list-style-type: none"> (a) restraint systems (b) protective helmets (c) other (5) Dummy design/analysis (6) Other
<p>II. ACCELERATOR SUBJECT</p> <p>A. Biological</p> <ol style="list-style-type: none"> 1. Human <ol style="list-style-type: none"> a. Cadaver <ol style="list-style-type: none"> (1) Storage (2) Handling (3) Monitoring (4) Anatomy b. Live <ol style="list-style-type: none"> (1) Transportation (2) Housing (3) Examination <ol style="list-style-type: none"> (a) Pre-acceleration (b) Post-acceleration 2. Non-Human <ol style="list-style-type: none"> a. Primate b. Other <p>B. Non-biological</p> <ol style="list-style-type: none"> 1. Instruments <ol style="list-style-type: none"> a. Recorders b. Transducers c. Telemetering devices d. Other 2. Mechanical devices 3. Other 	

(Continued)

TABLE I (Continued)

PRELIMINARY PROGRAM OUTLINE

III. EDUCATION/RESEARCH/SERVICE/
OPPORTUNITIES (Continued)

- B. Bioengineering
 - 1. Modeling of Human Dynamic Response to Acceleration
 - a. Fluid dynamics
 - b. Neuromuscular response
 - c. Skeletal response
 - d. Other
 - 2. Artificial organs
 - a. Bone substitutes
 - b. Other
- C. Medical Opportunities

IV. ACCELERATION FACILITY

- A. Location(s)
 - B. Number and Type of Accelerators
 - 1. Linear
 - 2. Rotary
 - 3. Non-Linear/Non-Rotary
 - C. Applications
 - 1. Engineering
 - 2. Medical
 - 3. Bioengineering
 - 4. Other
 - D. Support
 - 1. Personnel
 - a. Engineering
 - b. Medical
 - c. Service
 - 2. Facilities
 - a. Shop
 - (1) mechanical
 - (2) Electrical
 - (3) other
 - b. Medical (human/non-human)
 - (1) first aid
 - (2) examination
 - (3) x-ray
 - (4) housing
 - (5) other
 - E. Building and Physical Plant
 - F. Administration
 - 1. Facility Operation
 - 2. Contracts
 - 3. Leasing
 - 4. Service
 - 5. Scheduling
-

VI. RESULTS

This section of the report summarizes the results of the individual studies undertaken by each of the participating organizations. Where appropriate, detailed results of certain phases of the study are included as appendices.

A. Georgia Tech

The Georgia Tech study consisted of three separate efforts: 1) accelerator design, 2) interest of the Georgia Tech community in impact acceleration research, and 3) opportunities for impact acceleration research at Georgia Tech.

1. The Accelerator

At the beginning of this study the Navy specified the design requirements for its proposed impact acceleration program. These requirements were divided into Low and High Acceleration Requirements and are shown in Tables II and III respectively. The School of Aerospace Engineering conducted a survey of the capabilities of existing acceleration devices and determined that facilities did not exist which would meet the Navy's acceleration requirements. As a result of these findings, attention was turned to developing a design for an accelerator which would provide the required acceleration profiles. An engineering feasibility study showed that a facility which completely satisfies the Navy's specifications is technically feasible and economically reasonable. The detailed results of this effort are included in Appendix I together with an estimate of the cost of developing such a facility. This appendix also considers the location of the facility and proposes a program for its construction and operation.

TABLE II

LOW ACCELERATION REQUIREMENT

G	ΔG Increments	$\pm G_E$ Accuracy	Duration at Peak T	Duration at Peak $\pm T_E$ Accuracy	Duration at Peak ΔT Increments	Maximum V. (Ignoring Onset)	Accel. Distance Ft.	Maximum Stopping Distance	
								1 G Ft.	2 G Ft.
	(G)	(G)	(ms)	(ms)	(ms)				
0-10G	1	1/2	500	10	100	160 F.P.S. (107.3 mph)	40	400	200
10-20G	2	1/2	250	5	50		30	400	300
20-30G	2	1	170	5	35		20	400	200
30-40G	2	1	125	2.5	25		10	400	200

AT EVERY G:

Onset Rates dG/dt (Range) G/sec	Onset Rates $\Delta dG/dt$ (Increments) G/sec	Onset Rates $\pm \Delta dG/dt$ (Accuracy) G/sec
0-200G	200	50
2000-4000	400	100
4000-5000	500	150

ANCILLARY INFORMATION:

	<u>Min. Time to Peak</u>	<u>Distance to Peak</u>	<u>V @ Peak</u>
At 10G	2 ms.	-	-
20G	4 ms.	-	1.28 ft/sec
30G	6 ms.	0.005 ft.	2.88 ft/sec
40G	8 ms.	0.015 ft.	5.12 ft/sec

5000G per second probably excessive.
3000G sufficient in all probability.

TABLE III
HIGH ACCELERATION REQUIREMENT

G	ΔG Increments	$\pm G_E$ Accuracy	Duration @ Peak T	ΔT Increments	$\pm T$ Accuracy	Maximum V. (Ignoring Onset)	M Accel. Distance (Ignoring Onset)	Stopping Distance for Max. Vel at End of Accel.	
								1 G	2 G
(G)	(G)	(G)	(ms)	(ms)	(ms)	(FPS)	(Ft)		
40- 60	4	2	100	15	2.5	160	6-2/3	462'	231'
60-100	5	3	50	10	2.5	160	4	574'	287'
100-150	10	4	30	10	2.5	144	2-2/3	506'	253'
150-200	10	5	15	5	1.0	96	3/4	196'	98'

G	Range ROA = G dG/dt	$\Delta dG/dt$ Increments	$\Delta dG/dt_E$ Accuracy
	Range of Onset Rates (G/sec)	(G/sec)	(G/sec)
40- 60	0-5000	600	150
60-100	0-5000	1000	300
100-150	5000-10000	5000	400
150-200	10000-40000	10000	2000

ANCILLARY INFORMATION:

	<u>Min. Time to Peak</u>	<u>N</u> <u>Distance to Peak</u>	<u>Z</u> <u>V @ Peak</u>	<u>Distance</u> <u>to End</u> <u>of Accel.</u>	<u>Max.</u> <u>Vel. at</u> <u>End of Accel.</u>
	(ms)	(Ft)	(Ft/sec)	(Ft)	(Ft/sec)
At 60	12	0.046	11.52	7.9	171.5
At 100	20	0.207	32	5.8	192
At 150	15	0.170	36	4.0	180
At 200	5	0.026	16	1.0	112

2. Interests of the Georgia Tech Community in Impact Acceleration Research

Preliminary to determining the interest of the Georgia Tech community in impact acceleration research, resource material was obtained in the form of papers 2,3,4,5,6,7,8/, reports 9/, motion pictures and slides. Captain Ewing visited the participating organizations in December of 1969 for the purpose of briefing the contact personnel. Every effort was made to present to the Georgia Tech community a comprehensive view of the past accomplishments, current needs, and future opportunities in the field of impact acceleration which might be of interest to the faculty and staff.

Using the program outline shown in Table I as a guide for discussion and the films and references obtained above, a series of conferences were held with representatives from the various schools, departments, and divisions. Of the 29 units contacted, 26 appointed representatives who attended one of the conferences. At the close of the conferences each department representative was given a questionnaire which is shown in Table IV. Table V tabulates the information provided through the questionnaire. From this table it can be seen that 14 (or about half) of the units of Georgia Tech would be interested in participating in the Navy's impact acceleration program if this work should be undertaken by Georgia Tech. Perhaps more significant is that only 6 units indicated that they would not use an acceleration facility if one were located on the campus. Also of significance is the fact that 6 units had previous experience related to impact acceleration. Therefore, from this survey it was determined that there was more than just casual interest in impact acceleration research and that an acceleration facility on the campus would find use, both for graduate research and for contract research.

TABLE IV
IMPACT ACCELERATION QUESTIONNAIRE

NAME:

DEPARTMENT:

I. Current or recent activities related to Impact Acceleration

- A. Acceleration devices
 - B. Acceleration effects
 - C. Other _____
-

II. If you checked Item I, please describe the activity briefly and include sponsorship.

III. Indicate Education/Research/Service Activities related to Impact Acceleration which are of interest to your department. (See Preliminary Outline for suggested subjects.)

IV. Would your department be interested in participating in research activities supported through the Army-Navy Impact Acceleration Program?

Yes

No

If yes, indicate probable areas of activity

V. If an accelerator were available on the Georgia Tech Campus, would your department utilize it for

- 1. Instruction
 - 2. Graduate research
 - 3. Contract research
 - 4. Would not use
-

TABLE V
SUMMARY OF RESPONSES FROM GEORGIA INSTITUTE OF TECHNOLOGY
TO IMPACT ACCELERATION QUESTIONNAIRE

Affiliation of Conference Attendee	Question Number				
	I	II	III	IV	V
COLLEGE OF INDUSTRIAL MANAGEMENT		no response			
GENERAL COLLEGE - SCHOOLS					
Biology	N	-	subject response to measurement, sub- ject-acceleration interaction	Yes	2,3
Chemistry	N	-	-	No	4
Information Science		no response			
Physics	-	-	general instrumentation	-	3
Psychology	N	-	g effects on performance	No	2
ENGINEERING COLLEGE - SCHOOLS					
Aerospace Engineering	N	-	system design, structural dynamics	Yes	2,3
Architecture		no response			
Ceramic Engineering	-	-	-	No	3
Chemical Engineering	N	-	-	No.	4
Civil Engineering	A,B	vehicular collision research	dynamic response of structural systems, human tolerance to impact acceleration	Yes	2,3
Electrical Engineering	C	instrumentation and control	modeling, instrumentation	Yes	2,3
Engrg.Sci & Mech.	A,B	response of structures to impact	-	Yes	2

(Continued)

TABLE V (Continued)
 SUMMARY OF RESPONSES FROM GEORGIA INSTITUTE OF TECHNOLOGY
 TO IMPACT ACCELERATION QUESTIONNAIRE

Affiliation of Conference Attendee	Question Number				
	I	II	III	IV	V
<u>ENGINEERING COLLEGE - SCHOOLS (Continued)</u>					
Industrial Engrg.	N	-	mathematical models, experimental design	Yes	3
Nuclear Engineering	C	small computer applications	modeling, neuromuscular response, radiography, data display & reduction	Yes	2,3
Mechanical Engrg.	N	-	-	No	4
Textile Engineering	A	vestibular stimulation	restraint systems	Yes	2
<u>ENGINEERING EXPERIMENT STATION - Divisions</u>					
Chemical Science & Materials	A,B	response of model to underwater ejection	mechanical design, propulsion, bone substitutes	Yes	3
Electronics	C	biotelemetry	biological monitoring, sled-subject interaction	Yes	3
High Temperature Materials	N	-	skeletal response, dummy design, bone substitutes	Yes	3
Industrial Develop.	N	-	market development for potential mfrs.	Yes	3
Nuclear & Biological Science	C	small computer applications	modeling, neuromuscular response, radiography, data display & reduction	Yes	3
Physical Sciences	A,B,C	respiratory efficiency, structure response, accel research, impact effect on electronic components	failure analysis of materials, transducer development, physiological measurements	Yes	2,3

(Continued)

TABLE V (Concluded)
 SUMMARY OF RESPONSES FROM GEORGIA INSTITUTE OF TECHNOLOGY
 TO IMPACT ACCELERATION QUESTIONNAIRE

Affiliation of Conference Attendee	Question Number				
	I	II	III	IV	V
<u>CENTERS</u>					
Rich Elec. Computer	N	-	computer programming	Yes	4
Health Sys. Research	N	-	modeling, emergency medical syst.	No	4
Environmental Resources	N	-	social factors	(?)	4

3. Opportunities for Impact Acceleration Research at Georgia Tech

Concurrent with the study to determine the interest in impact acceleration research at Georgia Tech, a continuing effort was made to become familiar with accelerator needs of other agencies such as the Department of Transportation, the Air Force, and the Army. This was an important consideration from the standpoint of identifying potential sponsors for future R and D support and in obtaining a broader view of the type of programs which might be of interest to the Georgia Tech community but not necessarily related to the Navy's program to determine human dynamic response to impact acceleration.

a. Government. In this phase of the study visits were made to the Naval Air Engineering Center, Army Medical Research and Development Center, National Highway Safety Bureau (Department of Transportation), and the Air Force Aeromedical Research Laboratory. From these visits it was determined that there was much interest in the establishment of an acceleration facility at Georgia Tech. The fact that such a facility would be an independent one, under a non-profit organization, was of particular interest to the Department of Transportation. They have a continuing need for accelerators to evaluate highway related safety devices and systems and must use an independent facility. Currently they are using the Daisy track at the Aeromedical Research Laboratory, Holloman Air Force Base, New Mexico, but are concerned over plans to close that facility. Likewise, the Army (Aviation Systems Command) at Fort Eustis has a continuing program related to man-rating of seats, belts, and other mechanical devices and requires the use of an independent facility.

b. Industry. Although visits were not made to any of the automobile manufacturers, this potential source of research support was considered. The

recent emphasis on automotive safety has resulted in a substantial increase in in-house impact research work being conducted by the major automotive manufacturers. However, this work is concerned primarily with vehicle design and utilizes anthropomorphic dummies as test subjects. Unfortunately, the quality of the data obtained using dummies is only as good as the quality of the dummy, or how well the dummy represents a living human subject. At the present time such dummies simulate the real subject in weight, size, mass (total and by parts), and articulation. Accordingly, there is reasonable simulation as far as damage to the automobile by the dummy is concerned. However, due to the lack of data concerning the human dynamic response to impact acceleration, there is essentially no correlation of the damage occurring to the dummy with injury which might have resulted in the human situation. Of course, in situations involving the gross total destruction of the dummy it would be assumed that the human subject would have been killed.

In order to design suitable structures and restraint systems that will provide for the ultimate safety of the human subject in an automobile accident, the automobile industry requires data that are not available at this time, but which will become available through the Navy's impact acceleration program. This situation suggests that the industry would have a keen interest in any facility that generated such data. Likewise, dummy manufacturers would be attracted to such a facility. Therefore, although such industrial organizations have their own accelerators and make use of other accelerators in their vicinity, there is every reason to believe that they would also make use of a facility (and staff) where quantitative human dynamic response data were being generated.

If Georgia Tech proceeds with the design, development, and operation of the advanced accelerator to provide for the Navy's requirements, the institute would have the most advanced acceleration capabilities in the nation. Such a facility would receive national attention and should attract research from all sectors of industry concerned with transportation safety. The fact that automobile accidents rate fourth in the cause of human death and are the number one killer for the age group of 5 to 25 years old suggests an increasing national interest in automobile safety in the future. Therefore, the development at Georgia Tech of an independent, advanced impact acceleration center would appear to be a wise investment in the future.

4. Contribution to Bioengineering

During the time that this acceleration study was being considered, the Georgia Institute of Technology and Emory University conducted a survey of bioengineering interests in Atlanta 10/. This effort established lines of communication between various life scientists and engineers and identified areas of competence and experience related to the field of bioengineering. The results of this survey suggested that there would be significant interest in the establishment of an accelerator facility in the Atlanta area from the standpoint of bioengineering research alone, and thus served as a positive factor in the decision to undertake the present study.

Shortly before the study was initiated, the Board of Regents assigned to the Georgia Institute of Technology the responsibility for recommending a course of action for bioengineering for the entire University System. This action resulted in the establishment of a Bioengineering Center to operate as a coordinating office for resources and programs in the bioengineering

field. During early 1970, as the Bioengineering Center began to function, an active interface was gradually developed with the accelerator program in order to provide coordinating services and keep the program in step with the new thrust. The fact that the performance of the Navy's program demands the interaction of biology and engineering assures that such a program would contribute to Georgia Tech's mission in Bioengineering.

5. Contribution to Education

An impact acceleration facility on the Georgia Tech campus should be a major contributor to graduate education and research in the field of Bioengineering as well as in the more traditional engineering fields. A review of Table V shows eight units of Georgia Tech that would anticipate the utilization of such a facility for graduate research. It would be expected that, once such a facility began operation, additional departments would become involved.

In addition to graduate research, an acceleration facility would provide opportunities for undergraduate education and training. Of particular significance is the fact that these opportunities would be in areas of engineering in which an increasing number of graduates will be involved in the future -- namely, areas directly concerned with the health and welfare of people.

B. Emory University

The Emory University study was concerned with 1) determining the interest of the Emory faculty and staff in impact acceleration research, and 2) determining the role that Emory would play in the Navy's program to quantify human dynamic response to impact acceleration. The survey of the Emory University faculty and staff concentrated on key departments in the Medical School and on the Yerkes Regional Primate Research Center.

1. Medical School Departmental Interests

In order to provide medical support for the human aspects of the Navy's impact acceleration research, it was obviously very desirable to have the participation of the Department of Internal Medicine. Unfortunately, the Chairman felt that the proposed program was not sufficiently in keeping with the general direction of the department. However, it was considered possible for an individual faculty member to participate in a consultant role as part of the private practice time available to him. This arrangement would, of course, contribute little to education or research and would limit the interdisciplinary aspects of the program insofar as interinstitutional participation is concerned.

A similarly negative response was initially obtained from the Department of Anatomy. However, one key individual who is a full professor of anatomy, the chairman of the Emory University Bioengineering Committee and Director of Research of the Emory University Regional Rehabilitation Research and Training Center not only was extremely positive towards the proposal, but submitted a general overview of the manner in which he and his co-workers might become involved in the program.

Other departments which indicated a direct interest in impact acceleration research and would participate in such a program were the Departments of Physiology, Neurosurgery, and Physical Medicine and Orthopedics. Interest was also expressed on the part of the Dental School.

2. Yerkes Regional Primate Research Center

When it became apparent that there were many reasons to defer consideration of the use of human subjects in the initial phases of Emory University's participation, emphasis shifted to the Yerkes Primate Research Center. The study here was concerned with determining the contribution that the Center might make in utilizing primates to assist in establishing limits of human tolerance to impact acceleration. The participation of Yerkes in this effort was considered of major importance since human subjects cannot be studied to the limit of their tolerance, and primates would be the obvious choice of subjects to obtain the needed data. Such an assumption is of course predicated on the establishment of a satisfactory correlation between primate dynamic response and human dynamic response to impact acceleration. In this connection it would be expected that chimpanzees would be the primate of choice for such research purposes.

The Yerkes Primate Research Center investigated three possible areas of participation in the Navy's impact acceleration program: a) animal housing, b) other supporting services, and c) research activities.

a. Animal Housing. The Yerkes Primate Research Center considered the possibility of providing housing and care for a colony of between 20 and 50 chimpanzees which might become available when the Holloman Air Force Base "Daisy Track" is closed. This study took into account housing, feeding, medical care, and maintenance of individual life records for each chimpanzee.

b. Other Supporting Services. A second area of concern was the provision of other supporting services connected with the use of primates in the impact acceleration program. These services include transportation to, and temporary housing and care at the acceleration facility, examination of the chimpanzees before and after each test run, pathology, necropsy and laboratory services, and direct responsibility and authority for the humane handling of the chimpanzees while involved in the program.

c. Research Activities. The activities studied fell into two distinct areas.

(1). Indirect. Research type support of acceleration research originated by other than Yerkes faculty, and acceleration experiments as a part of other research.

(2). Direct. Research originated by a Yerkes faculty member where the effect of acceleration on primates is the major objective.

Research involving the acquisition of physiological and psychological data, data interpretation, pathology, and all other activities that might be required in determining primate dynamic response to impact acceleration would be of interest to the Yerkes Primate Center. Primate research is an area in which the Center enjoys an international reputation and in which they would be able to make a major contribution to the Navy's program.

A study report prepared by the Yerkes Primate Center is included as Appendix II.

VII. PROPOSED PLANS FOR THE IMPACT ACCELERATION PROGRAM

A. The Navy's Program

The only quantitative data available on human dynamic response to impact acceleration have been accumulated by the Bioengineering Sciences Division, Naval Aerospace Medical Institute. These data were obtained using an accelerator at Wayne State University and have been reported at the 12th and 13th Stapp Car Crash Conferences 2,3/.

Forthcoming efforts on the Navy's program will be directed toward enlarging the acceleration test envelope achieved at Wayne State and obtaining the desired data concerning the associated human dynamic response. Eventually the acceleration test envelope will reach the limits of the Wayne State type accelerator and future progress will require an accelerator or accelerators that can provide the specifications shown in Tables II and III.

At some point in the program, volunteer human subjects will reach the limit of "comfortable" accelerations and another subject will have to be used. This subject may be a cadaver or chimpanzee or both. However, prior to using the new subject in the higher acceleration envelope it will be necessary to establish a correlation between the human dynamic response and the substitute subject dynamic response to the same range of impact acceleration parameters.

The final phase of the program will be the study of the substitute subject's dynamic response to increasingly high levels of impact acceleration, until the threshold of injury is determined. At this point the correlation model will be used to estimate the corresponding threshold of human tolerance to impact acceleration. Figure 1 is a schematic representation of the development of the program as described above.

At this time it is not possible to specify the acceleration parameters necessary to determine the threshold of human tolerance to impact acceleration, or to know at what point in the program the advanced accelerator (Tables II and III) will be required. However, it can be assumed that much initial work will be required to obtain the substitute-subject dynamic response to impact acceleration over the same range of impact accelerations for which human dynamic response is currently available. Additional work will be required to extent both the human and non-human subject to the limit of the Wayne State type of accelerator before the advanced accelerator is required.

B. A Plan for Georgia Tech's Program

1. Test Subject

The Emory University Medical School study determined that the Departments of Internal Medicine and of Anatomy would not assume an active role in the Navy program. These departments were considered necessary elements in the program if the Georgia Tech accelerator facility were to use live human subjects or cadavers. Therefore, at the present time these test subjects would not be considered in plans for a Georgia Tech program.

The Yerkes Regional Primate Research Center study revealed a major interest in participating in this program. Their interest included the housing and care of chimpanzees, supervision of the chimpanzees during the course of obtaining impact acceleration data, and major involvement in the research effort required to obtain chimpanzee dynamic response to impact acceleration.

This situation suggests that any live test subject in the Georgia Tech acceleration program will be non-human. It also suggests that the direction to take would be to establish an interinstitutional research program between

Georgia Tech and the Yerkes Primate Center to determine the chimpanzee dynamic response to impact acceleration, with the aim of correlating these data with existing human dynamic response data. The program would then be extended to determine the threshold of chimpanzee injury from impact acceleration. Based on the correlation model developed above, these data would be used to predict the threshold of human injury from impact acceleration.

2. Accelerator

a. Commercial Unit. A commercial accelerator of the Bendix Hyge type is capable of reproducing the impact acceleration parameters previously provided by the Wayne State accelerator. Therefore, a correlation model could be developed between the data on human dynamic response to impact acceleration thus far reported 2,3/ and new data on chimpanzee dynamic response to impact acceleration obtained from the Bendix unit. Such a facility would allow for the establishment of a critical link in the Navy's program in the shortest period of time. Referring to Figure 1 above, acquisition of the suggested commercial accelerator would permit initiation of Phase 3, having as its first objective to duplicate with the chimpanzee the work completed with the human subject in Phase 1.

At this time it is assumed that Phase 2 will be initiated by the Navy at some location other than Georgia Tech. It would also appear reasonable to assume that in order for this work to proceed in the shortest period of time, the accelerator would be of the commercial Bendix Hyge type. Phases 2 and 3 could thus be conducted concurrently and the correlation model developed for that part of the Navy's acceleration requirements which could be provided by the commercial unit. It is estimated that perhaps 2 to 3 years would be required to obtain these data and develop the correlation model.

b. Advanced Unit. The results of the engineering feasibility study conducted by the School of Aerospace Engineering showed that a facility which completely satisfies the Navy's specifications is technically feasible. Therefore, the immediate Georgia Tech program should include a detailed design effort leading toward construction of the advanced accelerator which would be required to complete Phases 2 and 3. From a scheduling standpoint, it is estimated that the advanced accelerator could be operational in 2 to 3 years. This time scale is consistent with the anticipated completion date of the lower acceleration requirements under Phases 2 and 3.

3. Location of the Facility

Early in the program it was agreed that in order to obtain the desired involvement of the Georgia Tech faculty and staff, the acceleration facility should be located on or adjacent to the Georgia Tech campus. This would be particularly important from the standpoint of education and faculty involvement.

The selection of a site on the campus depended upon the type of accelerator recommended, the availability of a building and/or land, and the desired proximity to those units of Georgia Tech which would be most involved in the research program.

Location of an existing building which could house the accelerator was considered desirable since the Navy would not be able to provide funds for building construction and these funds would therefore have to come from the State Board of Regents. Although Regents' approval of such a building could be expected, the time required to obtain a site and to design, approve, and construct a suitable facility would significantly delay the start of acceleration experiments.

The type of accelerator would of course influence the choice of locations. As shown in Appendix I, the advanced accelerator will require a track about 1000 feet long in order to provide for the specified rate of deceleration. For such a facility to be located on the campus, an underground track would probably be required.

On the other hand, the Bendix Hyge type accelerator requires a track of the order of 100 feet and possibly could be located in an existing building. But, as pointed out in Appendix I, it is desirable that the Bendix unit also serve as a prototype model for the development phase of the advanced accelerator, in which case a longer track would be required and an existing building would probably not suffice.

a. Commercial Unit. Figure 2 depicts the Georgia Tech campus and identifies three possible locations for a Bendix type accelerator.

Location 1 is the Civil Engineering Laboratory. Figure 3 is a plan of the ground floor of this building and shows a potentially suitable area for installing the accelerator. With the approval of the School of Civil Engineering, the indicated space 30 feet wide and 95 feet long could be made available, assuming that the Navy would provide for relocation of the laboratory and offices which currently occupy that space. The area involved is sufficient to accommodate a Bendix Hyge HY-12135 actuator and 80 feet of track. This facility would be capable of accelerating a 1000-pound payload to 62 g's with an actuation time of 65 miliseconds. The top speed of the sled would be 56 miles per hour. The fact that the School of Civil Engineering is actively involved in automotive accident research favors their potentially continuing interest in housing this facility. One disadvantage of this space is that it

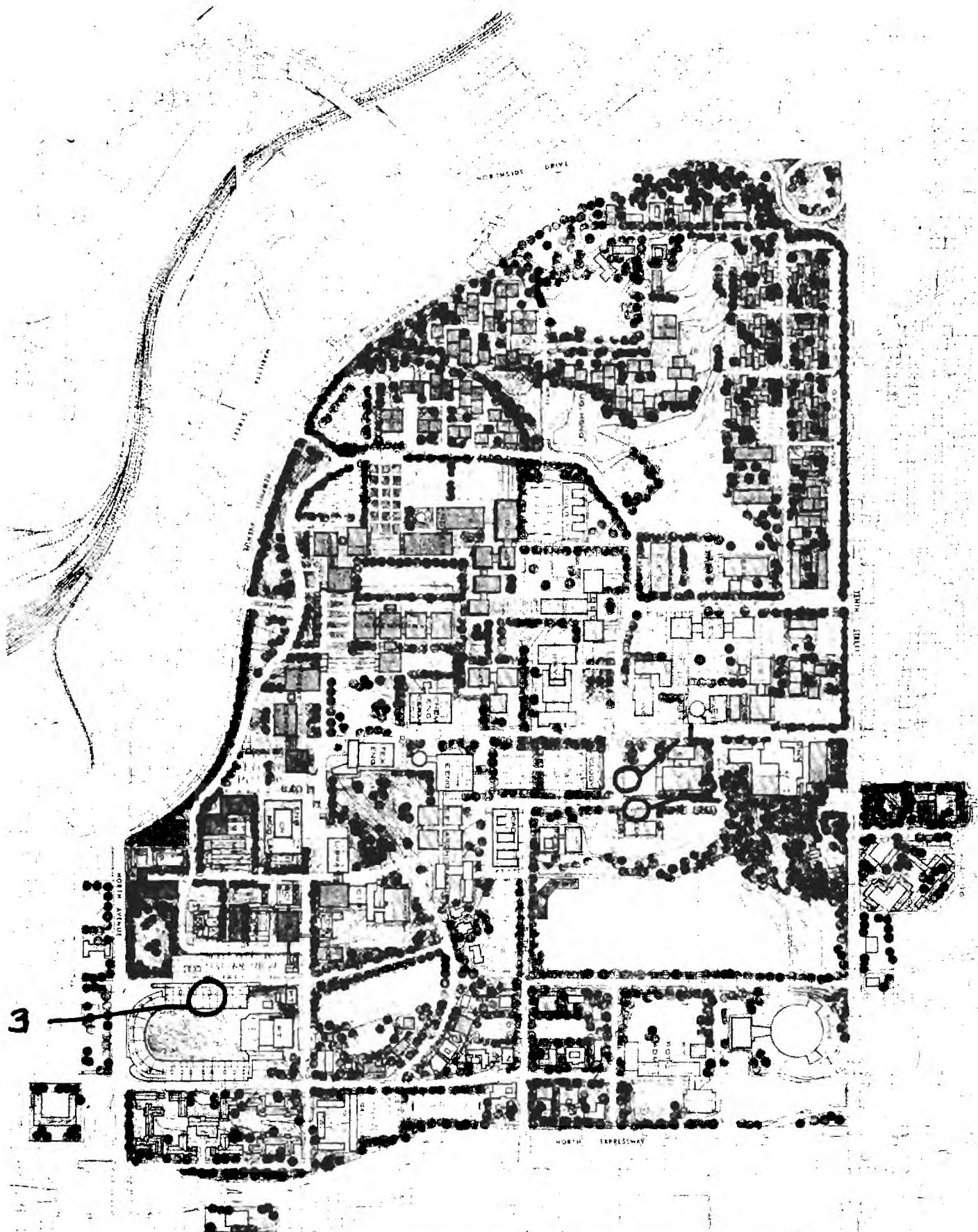
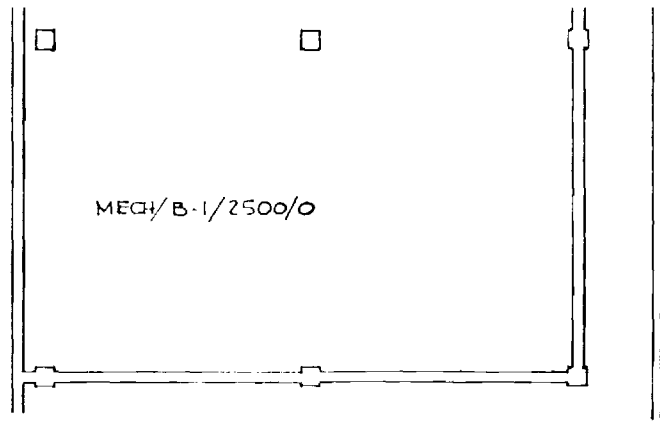
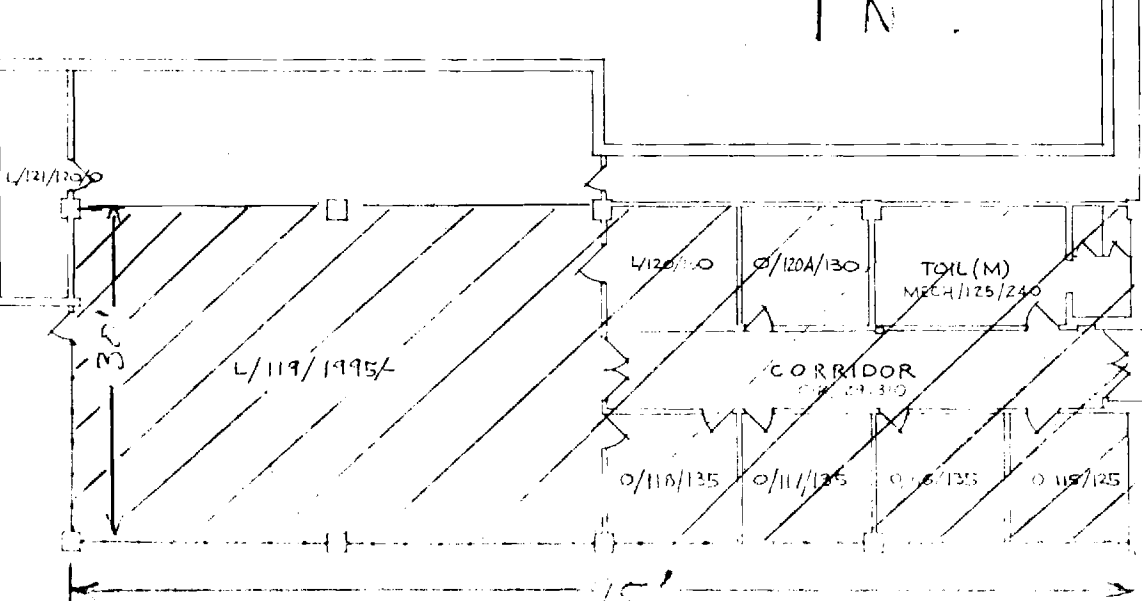
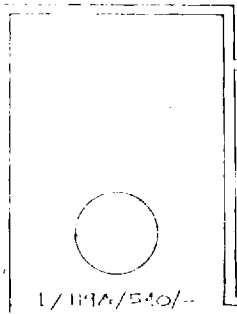
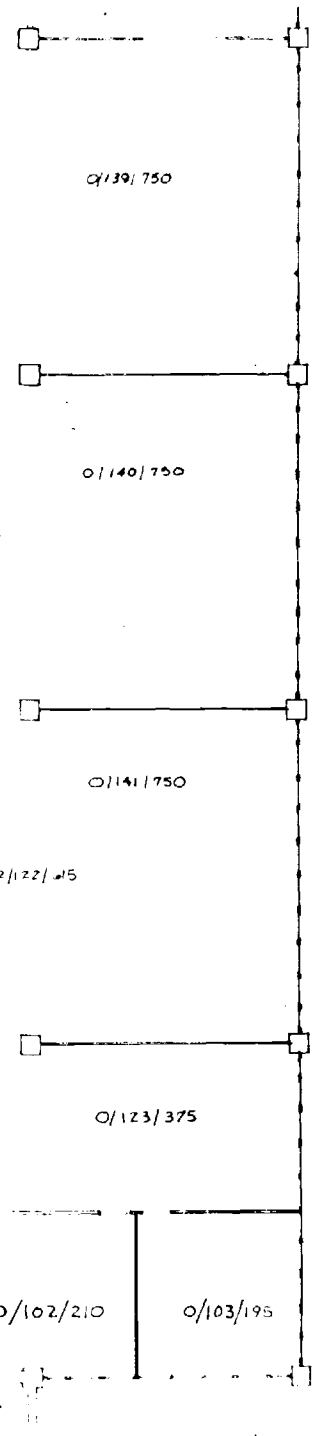
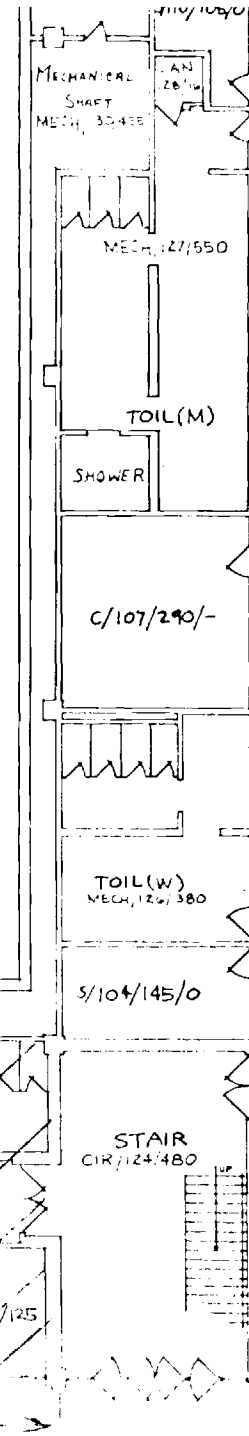

Figure 2. Georgia Tech Campus Showing Three Possible Locations for Commercial Accelerator.



BASEMENT



FIRST FLOOR

would permit only a limited future expansion of the facility (track length) and, therefore, would curtail use of the commercial accelerator as a prototype model for the advanced accelerator. The advantage is that impact acceleration research with chimpanzees probably could be initiated in the shortest possible time, by taking advantage of the existing enclosed space.

Location 2 is an open area adjacent to an isolated Departmental research building, known as the Aerospace Laboratory; it could provide for a track as long as 400 feet. At this time it is uncertain as to whether the facility would be above or below ground. This location has the advantage of providing the space needed to allow the Bendix unit to be modified and serve as a prototype model for the advanced accelerator.

Location 3 consists of excavated space, some 350 feet long, under the West Stands of the football stadium. Although this space is covered, a considerable amount of construction would be required to provide adequate housing for the facility and associated test equipment.

b. Advanced Unit. At the present time a campus site has not been located for the advanced accelerator. If the commercial unit were located on the campus, then a facility would have been provided which would serve the educational and faculty involvement requirement set out earlier. Under these circumstances, it is not critical that the advanced unit be located on the campus. In the event that an underground installation is desirable, there are a number of areas on the campus still undeveloped which could be considered.

4. Supporting Facilities

In order to undertake the complex bioengineering research associated with determining dynamic response to impact acceleration, a substantial support

effort will be required. Georgia Tech is particularly well equipped in this respect and anticipates that at least four supporting units would participate in this effort. These are the Rich Electronic Computer Center, and the Engineering Experiment Station's Electronics Division, Main Machine Shop, and Photographic Laboratory. Descriptive information on each is included under Appendix III of this report.

VIII. RECOMMENDATIONS

This study has suggested the following three recommendations.

1. Establish a chimpanzee colony under the direction of Emory University's Yerkes Regional Primate Research Center. These chimpanzees would be trained for use in measuring chimpanzee dynamic response to impact acceleration, as a means of estimating thresholds of human injury to impact acceleration.
2. Initiate a joint research program between Emory University and the Georgia Institute of Technology to determine chimpanzee dynamic response to impact acceleration, and install a Bendix Hyge HY-12135 actuator on the Georgia Tech Campus as part of this program.
3. Initiate a detailed design study and model experimentation program with the School of Aerospace Engineering leading toward construction of an advanced accelerator capable of meeting all of the Navy's specifications as shown in Tables II and III.

REFERENCES

1. G. S. Kolsrud and A. J. Hoisman, "Development of a Method for Evaluating Means for Reducing Impact Injuries to Pilots in Aircraft Accidents," TR-69-68-7(U) June 1968.
2. C. L. Ewing, et al., "Dynamic Response of the Head and Neck of the Living Human to $-G_x$ Impact Acceleration," 12th Stapp Car Crash Conference, December 1968.
3. C. L. Ewing, et al., "Living Human Dynamic Response to $-G$ Impact Acceleration II — Accelerations Measured on the Head and Neck," 13th Stapp Car Crash Conference, February 1970.
4. L. M. Patrick and D. J. Van Kirk, "Vehicle Accelerator Crash Simulator," 12th Stapp Car Crash Conference, December 1968.
5. L. C. Lundstrom, "Vehicle Crash Research and Manufacturing Experience," Society of Automotive Engineers, West Coast Meeting, August 12-15, 1968.
6. Charles W. Gadd, et al., "A Study of Head and Facial Bone Impact Tolerances," General Motors Seminar, July 11, 1968.
7. C. L. Ewing, "Vertebral Fracture in Jet Aircraft Accidents: A Statistical Analysis for the Period 1959 through 1963, U. S. Navy," Aerospace Medicine, Vol. 37, No. 5, May 1966.
8. W. G. Cichowski, "A Third Generation Test Dummy - Sophisticated Sam," General Motors Corporation Automotive Safety Seminar, July 11-12, 1968.
9. J. W. Turnbow, et al., "Crash Survival Design Guide," USAAVLABS Technical Report 70-22, Contract DAAj02-67-C-0004, August 1969.
10. J. D. Walton and S. B. Chyatte, "A Survey of Bioengineering Interests in Atlanta," Georgia Institute of Technology, July 1, 1969.

APPENDIX I

GEORGIA TECH AEROSPACE ENGINEERING STUDY REPORT
ON ADVANCED ACCELERATOR DESIGNS

INTRODUCTION

Ever since the pioneering work of Colonel Stapp there has been a growing interest all over the world in the effect of high "g" forces on human beings. It is clear that the problems which result from such an environment are psychological, physiological, human structural and mechanical. It is self-evident that a sound knowledge of these questions is of great importance if we are to ensure the survivability of the occupants of any vehicle which crashes. As a consequence of this vital need for knowledge, equipment designers have produced a wide variety of test vehicles designed to expose human, animal and manikin subjects to the environment of interest. Generally speaking, these devices have achieved the "g" levels of interest under a deceleration condition. However, there is strong evidence to show that an acceleration rather than a deceleration environment is technically more enlightening and desirable. Unfortunately, however, the achievement of high "g" levels in acceleration is much more difficult than in deceleration. The United States Navy-Army research team, which in recent times has been most active in this field of research has proposed a spectrum of acceleration conditions which should be met in a facility which would play a leading part in the study of the issues of concern. The present report summarizes a detailed study which was undertaken, in the School of Aerospace Engineering, to establish the feasibility of these requirements.

General Technical Discussion

The acceleration spectrum which the proposed facility should meet is given in Tables II and III above (pp. 12-13). It should be noted that the system specified differs from the norm in that the extreme acceleration levels to be prescribed are to be achieved from a standing start.

This statement should not be taken to imply that no prior facilities have attempted to produce "g" levels on subjects which were initially at rest, but rather to state that such attempts which have been made usually have been confined to much lower peaks, i. e. 50g or below, or have sustained the peak loading for much shorter periods.

However, irrespective of whether the system is to be an acceleration or deceleration facility, the subject, living or otherwise, whose reaction to or action under a prescribed acceleration profile is to be observed, must be carried on a special sled. It is clear that the precise character of this vehicle is not essential to the preliminary considerations; nevertheless, its general character is. It is the general character of this vehicle and the demands on it which determine its mass. The mass of vehicle in turn establishes the magnitude of the force parameter of concern. For the purposes of this study we shall fix a gross sled weight of 5,000 lbs. A weight of this magnitude seem sufficient to cover all configurations of potential interest.

The prime technical question then is how can a body of 5,000 lbs. weight be caused to accelerate from rest in the manner delineated in the naval specification? The answer is clear: it must be subjected to a virtually instantaneous force of up to 1,000,000 lb. magnitude (to meet the 200g case), and this force must be sustained over an appropriate time interval or travel distance.

There are a wide variety of methods of generating force, but the extremely rapid rate of force production which is consequential upon the demands of the specification rules out the majority. Indeed, it is clear that if a direct force-producing system is to accomplish the task this system must depend in some manner or another upon the principle that its actuating or force-producing device is at the zero or inactive state in

unstable equilibrium. It must be the very slight perturbation of this inactive condition which gives the instantaneous response. Constancy of force over a prescribed interval of time or displacement implies that the required system must store a very large quantity of energy in excess of that demanded, and that the release of this energy in a controlled manner and amount must be possible.

Such an approach is, of course, not the only way in which the objective could logically (but not necessarily practically) be achieved. A second approach can clearly be based upon the fact that force is the rate of change of momentum. Hence, a momentum transfer process is a potential solution. Such a system would utilize an appropriate mass, moving with correct velocity, being caused to impact with the sled. (This system is of course analogous to propelling a golf ball by impacting it with a swinging club.) The precise interaction between the impactor and the sled is a function of the mass velocity of the impacting mass, the mass of the sled, and the nature of any intervening device.

Methods of meeting the Naval requirement based upon the two principles given above follow.

INSTANTANEOUS DIRECT FORCE GENERATOR

It is relatively simple to evolve an instantaneous force generator based on the principles outlined in the discussion above. Such a force generator is shown in Figure 1. High pressure air from a large reservoir is connected to the main body of the thruster tube. The thruster piston is held in the ready position by the differential between the pressure in the main thruster tube and that in the launching cavity. The thrust sequence is initiated by firing the launching squib, which raises pressure in the launching cavity above that in the thruster tube and starts the motion of the piston.

During initial motion of the piston down the tube, the exposed area behind the piston is continually increased, accomplishing programmed force onset. Maximum force is a function of thruster tube pressure and piston area, and is held very nearly constant by virtue of the extremely large volume of air available in the reservoir. The piston stroke is stopped and return to the ready position is initiated by the arresting cylinder, which is positioned in the thruster tube and locked in place by magnetically actuated dogs. As the piston approaches the ready position the launching cavity is vented and the piston "captured" in the ready position by the reduced pressure there. The thruster is now ready for an immediate recycle.

This device has something in common with the force generators developed under the name HYGE and sold as a part of the Dynatest line of impact sleds by the Scientific Instruments and Equipment Division of the Bendix Corporation. However, the system proposed in Figure 1 differs in many important respects from the HYGE actuator. The first important difference lies in the fact that the thruster piston moves without restraint

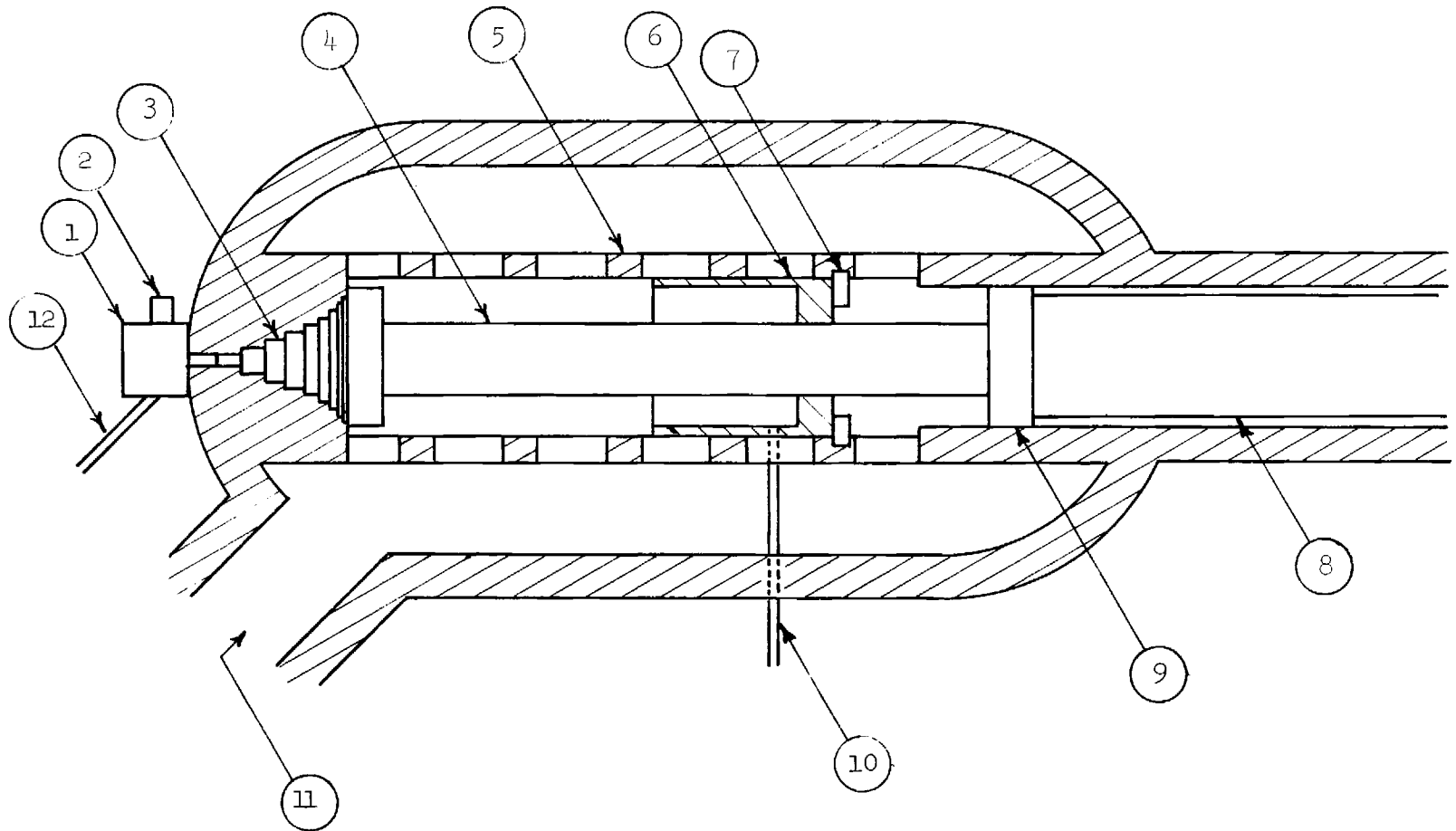

- | | |
|--|----------------------------------|
| 1. LAUNCH/CAPTURE SEQUENCING VALVE | 7. MAGNETIC LOCKING DOG |
| 2. LAUNCHING SQUIR | 8. THRUSTER |
| 3. G-ONSET PROGRAMMER/ARRESTING PISTON | 9. SEALING PISTON |
| 4. CONNECTING ROD | 10. RETURN BOOST AIR |
| 5. PERFORATED THRUSTER TUBE | 11. LINE TO HIGH PRESSURE PLENUM |
| 6. ARRESTING CYLINDER | 12. VACUUM LINE |

Figure 1. INSTANTANEOUS DIRECT
FORCE GENERATOR

during the acceleration phase, and the ratio of initial volume to extended volume of the apparatus is kept virtually at unity by making the volume of the pressure vessel extremely large relative to that swept out by the piston. These factors result in a period of constant force and thus constant acceleration, which is not obtainable from the HYGE actuator. The inclusion of an internal arresting piston and cylinder permits a rapid (virtually instantaneous) recycling of the thruster, and eliminates the necessity of an outside "cocking" mechanism.

It is clear from the wide range of acceleration profiles in the specification, that a single device operating on this principle would be out of the question. This is due to the large variations in force and stroke required to achieve the various profiles. In the interests of economy, then, the larger percentage of the high pressure storage system is designed to be a reservoir, which may be readily disconnected from the thruster tube, i. e. from the actuator proper. Thus, a change of the thruster tube portion may be made, in effect installing a new machine for each group of tests. In addition, the stroke length is variable in each individual thruster tube, as is the onset programmer, thus permitting variation of onset rate and duration of the stroke.

MOMENTUM EXCHANGE ACCELERATOR

Another possible means of accelerating a 5000 lb. subject sled is found in a momentum exchange system (Figure 2). An impactor, a specially shaped vehicle with a novel skirt seal and made of variable mass by filling or partially filling with water -- frozen to avoid sloshing, is accelerated down a large tube by a relatively low air pressure behind it. Emerging from the tube, it strikes the subject sled and accelerates it. G-onset is programmed by a pneumo-hydraulic device on the front of the impactor. Maximum "g" is determined by the velocity and mass of the impactor, and is controlled by the programmer. Once the acceleration phase has been completed the impactor is brought to a stop rapidly by a sand brake; the sled is decelerated more gently.

Air for propulsion of the impactor is stored at high pressure, thus reducing the volume required to about 1/30th that of the accelerating tube. Multiple inlet and relief valves distributed along the tube maintain tube pressure at the desired value to achieve the required velocity. Because of the novel skirt seal and by virtue of sliding the impactor on an ice surface, the accelerator tube is not required to be highly accurate in form or alignment.

Development of the low-pressure-air seal on the impactor will be required, although the principle is not essentially different from that of the well known oil-film shaft seal. In addition, it is possible that the tube will have to be partially evacuated to preclude excessive aerodynamic interference with the acceleration of the impactor. If so, this will require development of a bursting diaphragm system to separate the tube from the test section, but the problem is well within the state of the art.

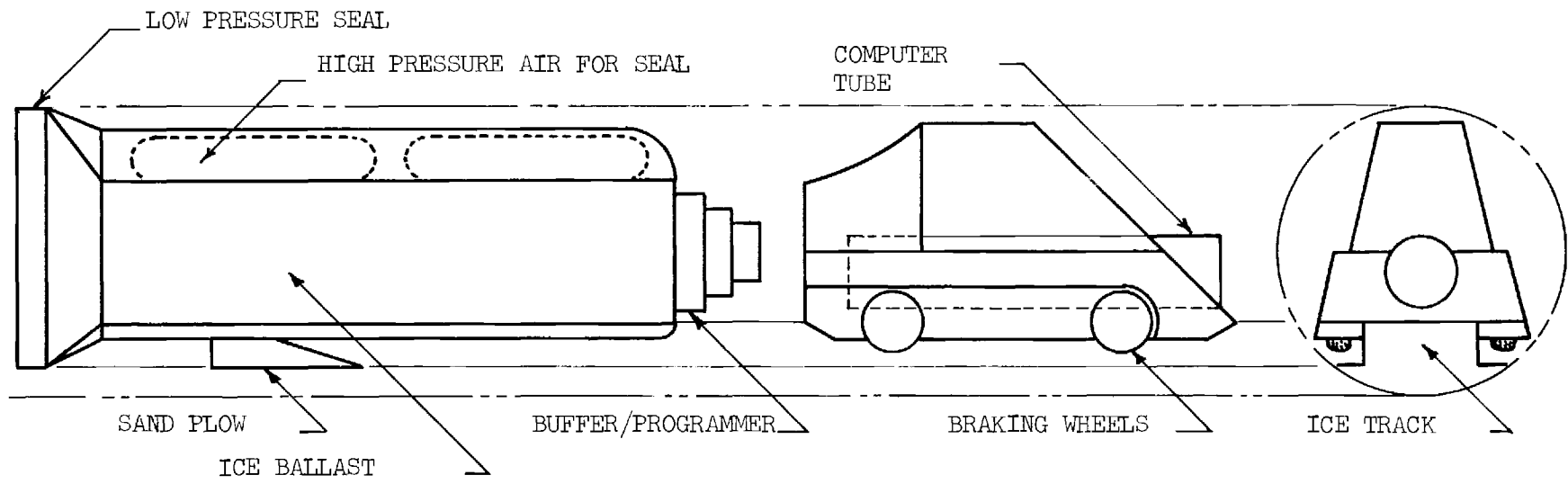

8

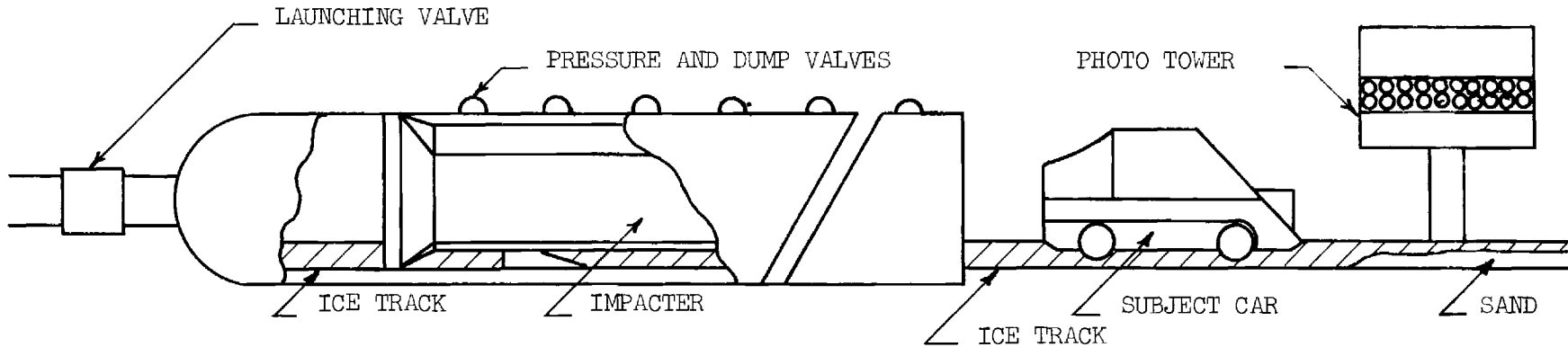

Figure 2. MOMENTUM EXCHANGE ACCELERATOR

In order to insure an accurate impacter velocity input, a linear induction motor is incorporated in the tube track as a velocity trimmer. Although use of the LIM as the sole propulsion mechanism would require a prohibitively large expenditure of electrical power, its use to provide a 5% acceleration or deceleration to the impacter would guarantee precise adherence to the desired acceleration profile and would be within the state of the art.

INSTRUMENTATION

Conventional instrumentation methodology for monitoring acceleration tests has been conceived with conventional accelerator capabilities in mind; thus, in some areas it is grossly inadequate for application in a facility which meets the naval specification. Considerable development work is anticipated in devising accelerometers capable of measuring the extreme "g" forces involved yet small enough to be biologically compatible and light enough to ensure that subject mass distribution would not be significantly altered. Conventional methods of recording electrical data, e. g., trailing wires, sliding contacts, etc., are unsuitable for use both in the extremely high-"g" regime, and in the long-duration lower-"g" regimes as well. It is therefore necessary to develop a means of recording this data on-sled. Preliminary studies indicate that it will be possible to design an electronic computer system which will sample 20 channels of electrical data, convert them to digital form, and store them in memory. Such a system would, of course, involve pneumatic cushioning to reduce the acceleration environment seen by the computer by a factor of ten at the high-"g" end of the test spectrum. Programming of changes in sample rate and a wide variety of sled functions would be accomplished readily utilizing the computer.

Photographic coverage during the acceleration phase of the test would be most efficiently accomplished by using exterior (stationary) cameras. During the deceleration phase, on-sled cameras could be actuated by the computer to provide coverage during the relatively long travel required to stop the sled.

SLED AND TRACK

Although the principles of rocket sled and track design are well understood (see, for example, ISTRACON REPT 60-1 "Rocket Sled Design Handbook"), this facility is quite different from existing tracks. The test section is located at the head of the track, rather than its end, and the test proceeds from zero to maximum velocity rather than the reverse. The intent is to isolate and identify the physiological effects of specific acceleration profiles; thus, accelerations extraneous to that profile (including those involved in stopping the sled) must be minimized.

Conventional rocket-track sleds are supported by metallic slippers riding on steel rails. As the sled velocity builds, a thin film of molten metal forms between the slipper and the rail, providing a smooth surface. Unfortunately, in the facility under consideration the test would be over by the time the metal film formed: in higher-"g" tests the entire acceleration program is completed in less than 10 feet of travel. In addition, the ride during the deceleration phase must be very smooth to prevent the masking of test effects by effects due to loads encountered in stopping.

These conditions impose new requirements on the track/sled combination which would be very difficult to meet using conventional methods. It seems likely that an entirely new approach will have to be taken. It is felt that advantage might result from use of an ice sheet as the track surface, with special skids on the sled. An alternative approach would be to use a precast-beam track, with ice slippers on the sled. Either of these methods can provide the smooth ride required from low to high velocity, and either method should prove economic. Both require development.

RESEARCH AND DEVELOPMENT REQUIREMENTS

At this point in the study neither the Instantaneous Direct Force Generator nor the Momentum Exchange Accelerator is clearly superior. Thus, it is recommended that further research be conducted in the following areas related to accelerating devices:

1. Momentum Exchange Accelerator

- a. Design and model test the high pressure pneumatic seal.
- b. Investigate the requirement for, and if required, design and model test the bursting diaphragm.
- c. Design and model test the linear induction motor trimmer.

2. Instantaneous Direct Force Generator

Design and model test the IDFG, with special attention to:

- a. Onset programming valve operation.
- b. Return of thruster by arresting cylinder.
- c. Capture of thruster by launching cavity.

3. Instrumentation

- a. Design the computer data acquisition and storage system.
- b. Design and model test the pneumatic cushion for the data acquisition and storage system.
- c. In conjunction with Navy medical personnel, develop suitable accelerometers.

4. Track and Sled

- a. Conduct a detailed study to permit decision between the ice track and ice slipper approaches to the track/sled problem.
- b. Design and model test the track/sled configuration which is chosen.

APPENDIX II

STUDY REPORT OF THE YERKES PRIMATE CENTER

9/3/70

THE YERKES REGIONAL PRIMATE RESEARCH CENTER
OF
EMORY UNIVERSITY, ATLANTA, GA.

A STUDY REPORT

Requirements for a chimpanzee housing and operational facility in support of an impact-acceleration research program in the Atlanta area, and the feasibility of The Yerkes Primate Center operating such a facility and providing laboratory and research support.

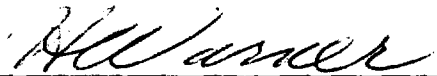

Hal Warner, Asst. Prof.
Chief, Biomedical Eng. Lab.

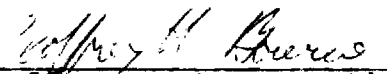
Approved: 

Geoffrey H. Bourne, Ph. D.
Director

I SUMMARY

With the addition of the necessary housing, operational facilities and personnel, the Yerkes Primate Research Center, given the responsibility and authority for the humane handling of the animals during the course of the acceleration research, is interested in maintaining and caring for the chimpanzees employed in the research in the Atlanta area and also in supplying limited critical laboratory and biomedical services support for the research itself.

The interest of our faculty in acceleration research on primates is of an indirect, support nature at the present time. None of the present faculty has indicated an interest in originating a research program where the major emphasis of the research concerns the effects of impact-acceleration on primates. Of course it is quite possible that, through our involvement in this program, researchers with this primary research interest could join our faculty.

II INTRODUCTION

While the mission of the Yerkes Regional Primate Research Center emphasizes the in-depth study of the biology of great apes, one of its major concerns, employing the data developed, is to study the biological bases for human physical, mental, and social disorders, and to apply these data to help solve problems of human health and disease. It can be seen, then, that the involvement of the Yerkes Primate Center in acceleration studies with primates for purposes of studying human physical safety does not depart much, if at all, from its basic mission.

Accordingly, the Yerkes Primate Center undertook to study the feasibility of involving itself in the impact-acceleration study in three areas. The first and most important area was animal housing and care. Here we considered normal routine care and also that care necessary for animals having special problems as a result of acceleration experiments. The second contained supporting services and included those veterinary and laboratory services necessary to support the experiments. The third and last area studied included the actual research activities within which primate center faculty members might involve themselves either in support of, or initiation of impact acceleration studies.

In order to gain background information, several conferences were held with Captain Channing L. Ewing of the Naval Aerospace Medical Institute and Mr. Jesse D. Walton of the Georgia Institute of Technology. In addition, one-day trips were made to the Naval Air Engineering Center at the Naval Base in Philadelphia, Pa., the Aeromedical Research Laboratory at Holloman Air Force Base in New Mexico, and the Office of Naval Research and the Department of Transportation in Washington, D. C. The purpose of these

trips was to gather information relative to the present state-of-the-art of accelerators and decelerators, the general philosophy of using large non-human primates as the subject of these experiments, and the manner in which these large animals should be quartered to facilitate handling before, during, and after such experiments.

III ANIMAL HOUSING AND CARE

This area of the study was based on the following inputs:

1. A maximum of 25 chimpanzees would form the pool from which animals would be selected for the impact-acceleration experiments.
2. As many as five animals might be expected to participate in acceleration experiments in any one day.
3. It is not expected that the animals returning from these experiments would have received severe physical injury as a result of planned acceleration impulses.

Requirements for housing, operations facilities, and care were studied to include both (a) animals requiring only normal routine care, not having injuries or special problems as a result of impact experiments and (b) animals involved in the acceleration experiments requiring special housing and care. Members of our faculty who are involved with chimpanzees and who have visited the Air Force aeromedical facility at Holloman Air Force Base, together with the supervisor of our large animal wing, our two veterinarians, and other members of our faculty and staff who possess expertise in these matters developed the design of a housing and operational facility. We were assisted by an expert builder who, in the past, has constructed several of our large animal compounds. This design is shown in the layout sketches of Figures 1 and 2.

The facility consists basically of two compounds 125 feet on each side, a row of 16 inside cages or dens, and an operational building connected

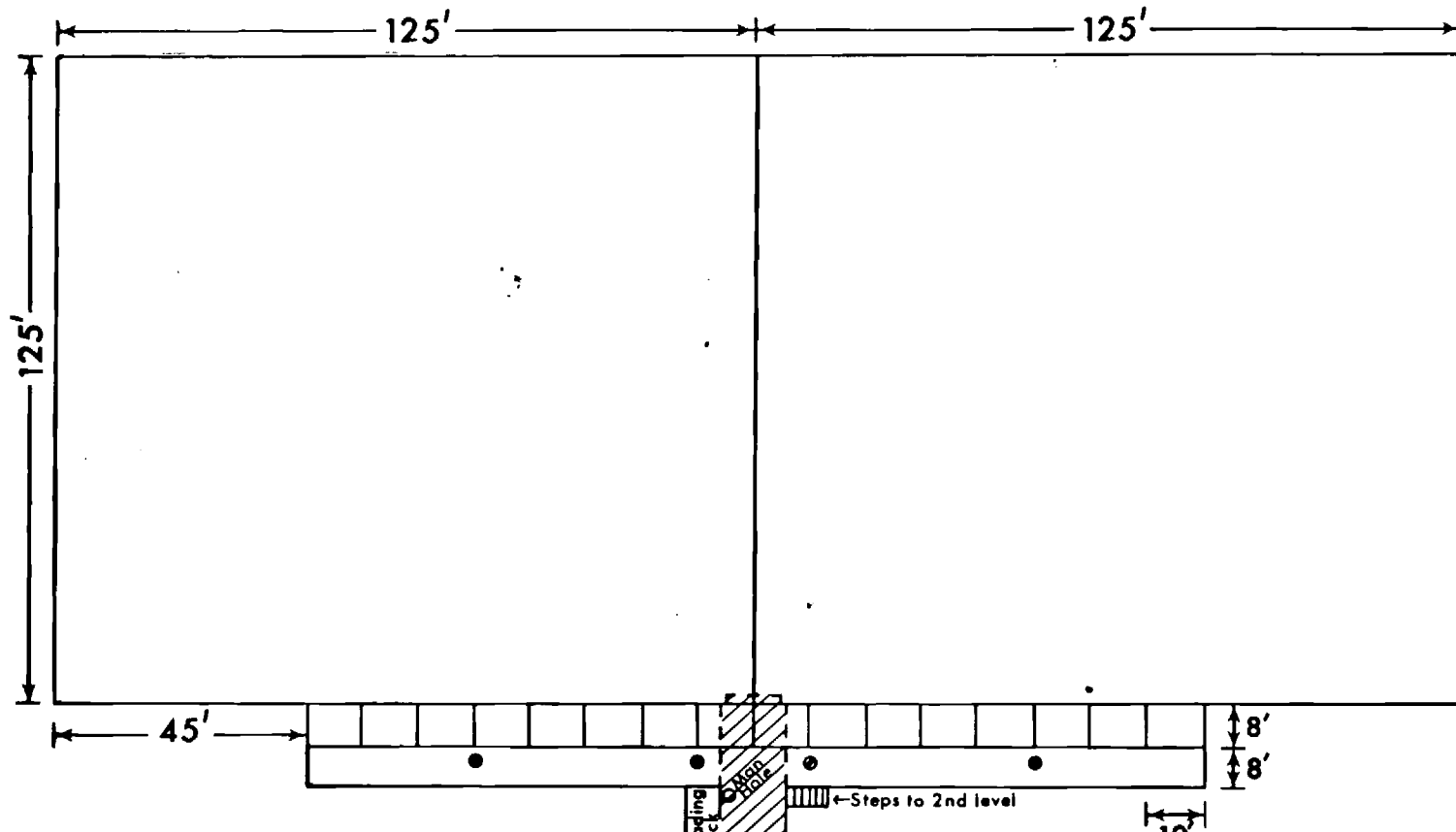

APPROXIMATE
SCALE $\frac{1}{10'}$

AREA FOR 2nd LEVEL

1st LEVEL

COMPOUNDS:

(2) $125' \times 125' = 15,625$ sq. ft.

CAGES:

(16) $8' \times 10' = 80$ sq. ft.

CONNECTING CORRIDOR:

$12' \times 12' = 144$ sq. ft.

FACILITY BLDG.:

$40' \times 50' = 2,000$ sq. ft.

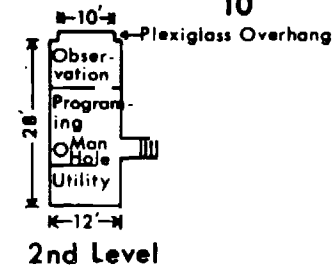
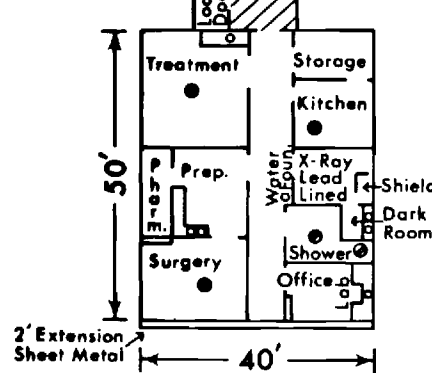

2nd LEVEL

OBSERVATION DECK:

Over compound
 $10' \times 2' = 12$ sq. ft.

Over housing area
 $8' \times 12' = 96$ sq. ft.

PROGRAMING ROOM:

$12' \times 12' = 144$ sq. ft.

UTILITY:

$8' \times 12' = 96$ sq. ft.

FIGURE 1

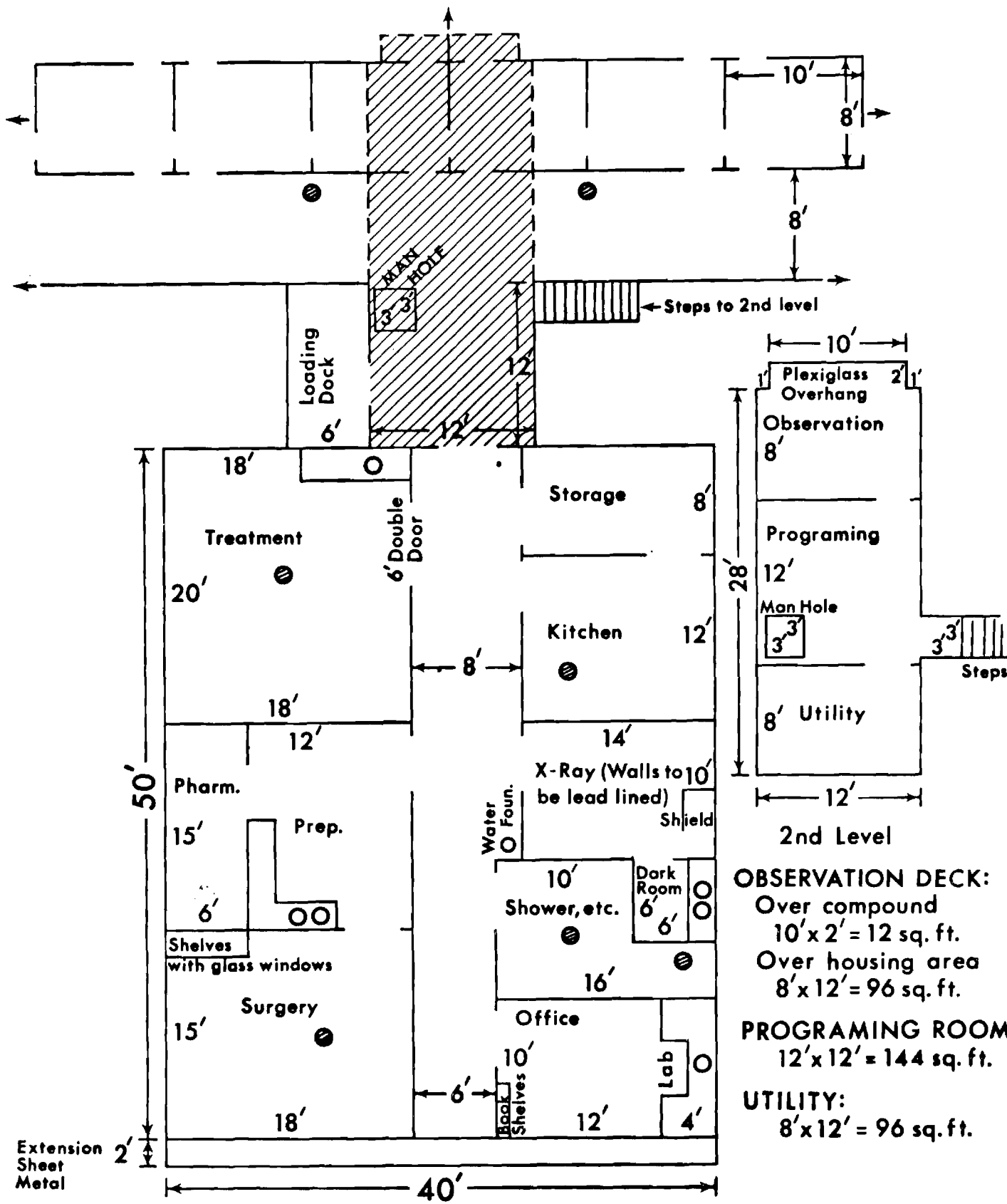

1st Level

CONNECTING CORRIDOR TO HOUSING UNIT:
 12' x 12' = 144 sq. ft.

FACILITY BLDG.
 40' x 50' = 2,000 sq. ft.

2nd Level

OBSERVATION DECK:
 Over compound
 10' x 2' = 12 sq. ft.
 Over housing area
 8' x 12' = 96 sq. ft.

PROGRAMING ROOM:
 12' x 12' = 144 sq. ft.

UTILITY:
 8' x 12' = 96 sq. ft.

SCALE |-----|
 10'

AREA FOR 2nd LEVEL

FIGURE 2
 6

with the indoor cage area by means of a corridor. A second level, above the row of inside cages and the connecting corridor, contains an observation deck overlooking the compounds, a programming room for recording data and making measurements from psychological and physiological tests in the cages, and a utility room.

Under normal conditions ten or twelve dens would be sufficient for 25 animals. However, it was considered that one or more of the animals returning from an acceleration experiment, because of some special problem such as injury, disorientation or mild concussion, might not be properly accepted by the other animals and ought not to be injected into the compounds without special precautions. Thus, four extra cages were included as holding cages for these animals. Similarly, for normal routine care it would not be necessary to include facilities such as X-ray, surgery, etc.; the facilities in the main center building would suffice, as they do for the other large animals in the field station. However, the possible injuries and special problems of animals returning from the acceleration experiments making redundancy of these facilities necessary. Our own years of experience in handling large animals and the experience of the Aeromedical Research Laboratory at Holloman Air Force Base are reflected in the overall design of the recommended housing and care facility. It would be entirely feasible to locate this facility within the confines of the Yerkes Primate Center Field Station, which is approximately 45 minutes from the Georgia Institute of Technology campus.

With the addition of a veterinarian, a technician, a clerk, and four caretakers to the faculty and staff of the Yerkes Primate Center,

the above-described facility could be operated smoothly and efficiently in support of the acceleration experiments without seriously interfering with the normal research program being carried out in the Yerkes Primate Center. Of course it would be necessary to provide certain initial furnishings and equipment, transport cages, and the ever-necessary consumables such as food and drugs.

IV SUPPORTING SERVICES

In order to help evaluate the animals' physical response to the acceleration experiments, it will be necessary that certain supporting services are provided. These services would probably include:

1. Examination of each animal by a veterinarian before and after acceleration.
2. Specialized pathology and general laboratory services.
3. Histological studies.
4. Sacrifice and necropsy procedures in selected cases.

With the addition to our staff of one biological laboratory technician, it would be feasible to conduct a limited number of such services in the existing laboratories of the Yerkes Primate Center and the field facility described above. The limitation on these laboratory services would be determined by the level of interference with our basic Center research program. An appropriate vehicle and two experienced animal handlers would be required at the acceleration facility to manipulate the animals between the housing facility, transport cages and the experimental apparatus. Our veterinarians, veterinary pathologist, and superintendent of large animals generally would be in charge of these supporting services.

V RESEARCH ACTIVITIES

Several meetings of the faculty members of the Yerkes Primate Center were held, and the general philosophy of employing large non-human primates in impact-acceleration experiments was discussed. Captain Ewing attended two of these meetings and, as background for the faculty, described in detail the impact-acceleration work which had been done employing human subjects. He stressed the need for large non-human primates as experimental subjects in this work to enable investigators to exceed the injury or discomfort acceleration-impulse thresholds and, thus, gain valuable data which could contribute to the design of equipment for protection against impact. As a result of these meetings, presentations, and subsequent study, the faculty segregated their possible involvement in research activities into two areas which follow.

A. Indirect Research

This was defined as support of a research nature of other investigators not on the Yerkes faculty, whose prime concern was impact research. As an example, Yerkes faculty and staff could be involved in psychological or psychomotor tests of an animal before and after acceleration experiments where the protocol and/or apparatus involved in the tests required special design. The majority of the faculty members at Yerkes were of the opinion that this particular mode of research activity was both desirable and feasible with the addition of the necessary manpower, equipment, and supplies.

B. Direct Research

None of the faculty of the Yerkes Primate Center was interested in originating research at the present time, where the major objective

concerned the effect of acceleration on primates. They were of the opinion that the research programs they are currently involved in comprise a more important function of our overall mission and therefore they could not afford to have their efforts diverted. However, this sentiment does not preclude the establishment at this Center of one or perhaps two faculty chairs whose incumbents would be dedicated to investigations of this nature, funded either by research grants or direct agency funding.

APPENDIX III

GEORGIA TECH SUPPORTING FACILITIES

APPENDIX III

GEORGIA TECH SUPPORTING FACILITIES

A. Rich Electronic Computer Center

The Rich Electronic Computer Center was established in 1955 and its facilities are an integral part of the academic and research programs at Georgia Tech. The Computer Center operates two large-scale digital computers, a Burroughs B-5500 and a Univac 1108. Both systems have multiple-processing program capability.

The B-5500 system has the following configuration: two central processors, 32,768 words of core memory (48 bit words); 65,536 words of drum memory; a disk file system which provides 28,800,000 characters of additional storage; ten magnetic tape units; four input/output channels; two high-speed card readers (800 cpm each); one high-speed card punch (300 cpm); two high-speed line printers (700 lpm); and a console typewriter. Several general-purpose programming languages, such as ALGOL, COBOL, FORTRAN II, and FORTRAN IV are available for use by programmers.

The Univac 1108 system has the following configuration: one central processor; twelve input/output channels; 65,536 words of core storage (36 bit words) two magnetic memory drums (12 million characters each), two FASTRAN II mass storage units (132 million characters each); 4 magnetic tape units; and three 1004 sub-systems; each of the 1004 sub-systems consists of a small processor, a card reader, a card punch, and a line printer. Built-in double-precision processing permits rapid computation with 18 decimal-digit significance. Programming techniques include machine language, assembly language, FORTRAN V, ALGOL, and COBOL.

B. Electronics Division

A large part of the electronics research at Georgia Tech is conducted within the Electronics Division of the Engineering Experiment Station. The Division is housed in a new Electronics Research Building which has approximately 55,000 square feet of floor space and provides facilities for about 125 research workers. The building was specifically designed to provide the flexibility necessary to handle its many diverse projects with maximum efficiency. Division research programs are normally conducted within the Communications, Radar, and Special Techniques Branches.

1. Communications Branch Laboratory

This laboratory consists of both general-purpose and specialized facilities for communications research. These facilities provide for research, development, test, and evaluation of a wide variety of electronic and electro-mechanical circuits, equipments, sub-systems and systems.

The laboratory is well-equipped to cover basic requirements pertaining to amplitude, frequency, and time measurements and to signal generation and detection in the DC to 40 GHz range. Conventional instrumentation includes oscillators; signal generators; receivers; voltmeters; frequency counters; regular, sampling, and storage oscilloscopes; strip, tape, and XY recorders; "Q" meters; phase meters; spectrum analyzers; slotted lines; admittance meters; impedance bridges; tube, transistor, and FET testers; noise generators; sound and vibration meters; receivers; sweep generators; and power amplifiers.

Laboratory standards are maintained as a source of calibration. Standard 100 kHz and 1 MHz signals are available with absolute accuracies of better than 1 part in 10^{10} . Emergency power facilities are provided to prevent loss of frequency control when the primary power source is interrupted.

Equipment and circuit fabrication ranging from breadboards to advanced development models is made possible by model-shop and printed-circuit facilities.

An 8 x 16 foot mobile laboratory is maintained for operational field tests or propagation studies at remote field sites. Two aluminum telescoping towers, each having a maximum height of forty feet, are also available for field use.

2. Radar Branch Laboratory

The Radar Branch Laboratory has extensive facilities for the design, construction, test, and evaluation of experimental radar systems, and for the analytical and experimental solution of microwave and electronics research problems. Test equipment is available for measurements in all of the standard microwave radar frequency bands. In addition to standard test equipment, the laboratory has special-purpose computers for calculating antenna patterns by the Fourier integral method and for statistical analysis of radar return data.

Data recording equipment includes a multichannel magnetic recording system and a multichannel oscillograph. Both are capable of recording data with frequency components from dc to 5000 Hz.

Radar Branch also maintains a track-mounted, completely self-contained X-band dual polarization radar for use in a variety of operational field programs.

The staff includes teams skilled in the design and construction of microwave antennas, microwave transmitters and receivers, electronic instrumentation and control circuits, and mechanical devices.

3. Special Techniques Branch Laboratory

This laboratory provides unique facilities for research, measurement, and analysis in the frequency spectrum encompassing the millimeter and far-infrared regions and extending into the optical region.

A Michelson interference spectrometer which will operate over the 40 to 3000 GHz frequency spectrum is maintained. The spectrometer which has a 30 cm aperture and 2 meter effective path length is housed in a large vacuum chamber which permits measurements to be made under carefully controlled humidity and atmospheric conditions or for various test gases. Neon and argon plasma tubes, a crucible type oven, and a mercury arc lamp are available to drive the spectrometer and for use in radiometric measurements.

A sensitive cryogenic germanium bolometer with liquid helium transfer equipment is available, as are a Golay cell, evacuated bolometers, and point-contact crystal detectors. A phase sensitive lock-in amplifier system and digital recorder are used when very high sensitivity measurements are required. Complete test setups are available in WR-15 and WR-10 waveguide and include slotted lines, attenuators, diode detectors, evacuated barretters, wavemeters, and reflex klystron sources. Instrumentation includes equipment for measuring properties of dielectric materials and gaseous absorption in the frequency band from 50 to 1500 GHz.

A 4-inch, 2 meter laser tube is available with optics and power supply for use in the far infrared. This laser can be used with cyanide water vapor or other gases of interest.

C. Main Machine Shop

One of the major research-support operations at Georgia Tech is the

Main Machine Shop of the Engineering Experiment Station. Research personnel, design engineers, and the highly skilled Shop staff work together closely to produce specialized instrumentation for research projects, as well as complete experimental and prototype models of both precisely machined components and large mechanical and electro-mechanical systems.

The Machine Shop occupies an 8,500 square foot building containing a 10-ton overhead crane with a 60 foot span which can be operated over the entire length of the building. Over sixty different types of shop machinery and other apparatus offer complete and versatile facilities. Equipment includes thirteen engine lathes ranging in capacity from 6-inch x 18-inch centers to 66-inch swing x 14-foot centers, two combination horizontal milling machines with 36-inch table travel, six vertical milling machines, a 5-foot radial drill press, a 3 x 12-foot planer, an 8 x 24-inch surface grinder, an engraving machine, and an optical comparator. In addition, facilities are available for all types of welding, sheet metal work, and wood-working. The Machine Shop also maintains a tool room, which is well stocked with machine tools and hand tools.

In addition to the above machine equipment, a new two-axis, numerically controlled, vertical-spindle milling machine was recently acquired. This important new acquisition at Georgia Tech is a member of a class of automatically controlled machine tools developed during the last two decades. It offers machining capabilities far beyond those of conventional manually controlled equipment.

D. Photographic Laboratory

Georgia Tech maintains a modern, well-equipped photographic and

reproduction laboratory for printing and illustrating reports. It is housed in a new 14,000 square foot building which is next to the Library and is staffed by 22 employees. The staff includes six photographers highly skilled in still, cine, copying, processing, and halftone production. The Photographic Laboratory work is subdivided as follows.

(1) Reports. This section is responsible for reproductions and has the latest offset printing equipment for Itek, Xerox, and Photographic Offset.

(2) Art and Design. This section is staffed with an illustrator, four layout technicians, and one compositing operator. All of the latest equipment necessary in the practice of this craft are available for these personnel.

(3) Photographic Printing. Equipment and personnel are available for processing both 16 mm black-and-white cine film and still prints up to 11 x 17. Located in the immediate area is an Eastman Kodak Color Processing plant which can process overnight color cine film and color slides. The Georgia Tech Photo Lab has a contract with Cinema Processors, a local firm, which processes Georgia Tech's 16 mm color film on a while-you-wait basis.

(4) Photography. This section is well equipped with both still and cine cameras, as follows:

(a) Still Cameras. All standard cameras such as Leika, Nikon, motor-driven Nikon, Kinie Exacto, Hasselblad, Rolleiflex, Speedgraphic, 8 x 10 Deerdoff, and other similar equipment.

(b) Cine Cameras. Two Fastex, 100 ft capacity, with timer and control units; 16 mm Mitchell, 125 frames/sec, 1200 ft capacity; and six additional standard 16 mm cine cameras.

DOCUMENT CONTROL DATA - R & D

Security classification of title, body of abstract and indexing annotation must be entered when the overall report is classified

1. ORIGINATING ACTIVITY (Corporate author) Engineering Experiment Station Georgia Institute of Technology Atlanta, Georgia 30332		2a. REPORT SECURITY CLASSIFICATION Unclassified	
		2b. GROUP	
3. REPORT TITLE AN ENGINEERING STUDY OF THE REQUIREMENTS FOR AN ACCELERATION FACILITY FOR BIO-ENGINEERING RESEARCH AND THE FEASIBILITY OF ESTABLISHING SUCH IN THE ATLANTA AREA			
4. DESCRIPTIVE NOTES (Type of report and inclusive dates) Final Report			
5. AUTHOR(S) (First name, middle initial, last name) Jesse D. Walton, Jr., Wilfred H. Horton, Samuel B. Chyatte, and Harold Warner			
6. REPORT DATE September 1970		7a. TOTAL NO. OF PAGES 71	7b. NO. OF REFS 10
8a. CONTRACT OR GRANT NO.		9a. ORIGINATOR'S REPORT NUMBER(S) A-1216	
b. PROJECT NO.			
c. Task No. N00014-67-A-0159-0006		9b. OTHER REPORT NO(S) (Any other numbers that may be assigned this report)	
d.			
10. DISTRIBUTION STATEMENT "Reproduction in whole or in part is permitted for any purpose of the United States Government."			
11. SUPPLEMENTARY NOTES		12. SPONSORING MILITARY ACTIVITY Office of Naval Research Requisition No. NR105-577/9-3-69(444)	
13. ABSTRACT This study has revealed a definite interest in acceleration research at Georgia Tech and identified potential participants in the Navy's program to determine human dynamic response to impact acceleration. The program has been recognized as one which is in the area of bioengineering and would contribute to the development and growth of this area of major thrust at Georgia Tech. Research and educational opportunities have been determined and are found to be consistent with the mission of Georgia Tech. Through the cooperative efforts of Emory University's Medical School and Yerkes Regional Primate Research Center, interinstitutional collaboration was realized in conducting this study. Potential participating departments at Emory University were identified and, in particular, the role of the Primate Center in the Navy's program was formulated. A plan for early acquisition and operation of a commercially available accelerator on the Georgia Tech campus was outlined, and a cooperative research effort with the Primate Center which would contribute to the Navy's impact acceleration program was suggested. Although the research effort thus described would advance the Navy's program to determine human dynamic response to impact acceleration, the accelerator would not be capable of providing all of the impact acceleration parameters specified by the Navy. In the course of this study, the School of Aerospace Engineering developed a conceptual design for an accelerator which satisfies all of the Navy's specifications. Based on this development the A. E. School proposed a program to design and construct the accelerator and to undertake the operation of the facility.			

14 KEY WORDS	LINK A		LINK B		LINK C	
	ROLE	WT	ROLE	WT	ROLE	WT
Acceleration Phisiology Crash Simulation Impact Acceleration Primate Research						