

**ACTIVE SAFETY LEADING INDICATORS FOR HUMAN-
EQUIPMENT INTERACTION ON CONSTRUCTION SITES**

A Dissertation
Presented to
The Academic Faculty

by

Eric Marks

In Partial Fulfillment
of the Requirements for the Degree
Doctor of Philosophy in the
School of Civil and Environmental Engineering

Georgia Institute of Technology
May 2014

COPYRIGHT © 2014 BY ERIC MARKS

**ACTIVE SAFETY LEADING INDICATORS FOR HUMAN-
EQUIPMENT INTERACTION ON CONSTRUCTION SITES**

Approved by:

Dr. Kimberly Kurtis, Advisor
School of Civil and Environmental
Engineering
Georgia Institute of Technology

Dr. Lawrence F. Kahn
School of Civil and Environmental
Engineering
Georgia Institute of Technology

Dr. Yong Cho, Co-Advisor
School of Civil and Environmental
Engineering
Georgia Institute of Technology

Dr. Patricio A. Vela
School of Electrical and Computing
Engineering
Georgia Institute of Technology

Dr. Paul Goodrum
Department of Civil, Environmental, and
Architectural Engineering
University of Colorado at Boulder

Date Approved: March 10, 2014

Dedicated to my wife Andrea for her unwavering support

ACKNOWLEDGEMENTS

I would like to acknowledge mentorship by Dr. Paul Goodrum and Dr. Donn Hancher during my time at the University of Kentucky. Their passion for research and teaching inspired and motivated me to pursue a career in academia. I would like to thank other members of my doctoral committee including Dr. Kimberly Kurtis (advisor), Dr. Lawrence Kahn, Dr. Yong Cho (co-advisor), and Dr. Patricio Vela for their time and advice. I also consider myself blessed to have participated on a research project with the late Dr. Jimmie Hinze who is one of the top construction safety researchers of our time.

Much of my success in graduate school at the Georgia Institute of Technology can be attributed to my fellow laboratory colleagues. The support of the members of the RAPIDS laboratory including Nipesh Pradhananga, Sijie Zhang, Tao Cheng, Soumitry Jagadev Ray, Kyungki Kim, Aaron Costin, Yihai Fang, Jun Wang, and Di Wang was critical to my accomplishments. I look forward to continuing professional relationships as well as friendships with these great people.

I am indebted to my parents and sisters for instilling work ethic and strong morals within me and supporting me through this time. My parents' passion for education and impacting the lives of others was transferred to their children. I am also thankful for the encouragement and support provided to me by the Tabor family during my tenure at Georgia Tech. None of this would be possible without the unconditional support from my family and friends. Lastly, and most importantly, I acknowledge my Lord and Savior Jesus for His unconditional love towards me.

TABLE OF CONTENTS

	Page
ACKNOWLEDGEMENTS	iv
LIST OF TABLES	ix
LIST OF FIGURES	xi
LIST OF SYMBOLS AND ABBREVIATIONS	xiv
SUMMARY	xvii
 <u>CHAPTER</u>	
1 Introduction	1
1.1 Overview	1
1.2 Motivation	2
1.3 Contributions and Impact	3
1.4 Thesis Organization	5
2 Background	6
2.1 Construction Industry Accident Statistics	6
2.2 Safety Leading Indicators	8
2.3 Human-Equipment Interaction	12
2.4 Equipment Operator Visibility	15
2.5 Focus	17
3 Research Hypothesis and Methodology	20
3.1 Introduction	20
3.2 Hypothesis	22
3.3 Objective and Scope	23
3.4 Framework	24

3.5	Near Miss Reporting Program	26
3.6	Operator Visibility Measurement	26
3.7	Technology Evaluation	27
3.8	Testing Method for Proximity Detection and Alert Systems	28
4	Near Miss Reporting Program for Construction Safety	29
4.1	Introduction	29
4.2	Background	31
4.3	Objective and Scope	40
4.4	Methodology	44
4.5	Results	47
4.6	Conclusions	63
5	Equipment Operator Visibility Measurement and Analysis for Safe Equipment Design	65
5.1	Introduction	65
5.2	Background	67
5.3	Objective and Scope	69
5.4	Research Methodology	70
5.5	Experimental Results and Discussion	77
5.6	Conclusions	88
6	Selection of Technology for Proximity Detection and Alert Systems for Construction Equipment Operation	91
6.1	Introduction	91
6.2	Background	93
6.3	Objective and Scope	109
6.4	Research Methodology	110
6.5	Experiments and Results	111

6.6 Conclusions	128
7 Position and Orientation of (Semi-) Passive RFID PPU's	131
7.1 Introduction	131
7.2 Background	132
7.3 Objective and Scope	133
7.4 Research Methodology and Results	133
7.5 Conclusions	142
8 Test Method for Proximity Sensing Technology	143
8.1 Introduction	143
8.2 Background	144
8.3 Objective and Scope	148
8.4 Testing Method for Proximity Detection and Alert Systems	149
8.5 Conclusions	162
9 Conclusions	165
9.1 Concluding Remarks	165
9.2 Limitations and Future Research	169
APPENDIX A: Construction Site Personnel Interview Questions	172
APPENDIX B: Construction Equipment Operator Visibility Measurement Results	179
APPENDIX C: Coverage Area Maps of Proximity Detection and Alert Systems Installed on Construction Equipment	184
APPENDIX D: Proximity Detection and Alert PPU Position and Orientation Experimental Results	191
REFERENCES	196
VITA	218

LIST OF TABLES

	Page
Table 1: Title and description of each thesis chapter	5
Table 2: Non-fatal injuries of the construction industry	8
Table 3: Categorization of research methodology sections	21
Table 4: Search criteria for recorded close call events	36
Table 5: Location of interview projects	44
Table 6: Interview project metrics	45
Table 7: Dependent variables of the near miss reporting interview data	48
Table 8: Steps and descriptions of the near miss process information flowchart	54
Table 9: Eindhoven classification system	56
Table 10: Visibility data from the plan view of each skid steer loader	80
Table 11: Summary of results for all skid steer loader models	84
Table 12: Operator visibility measurement results from different measurement methods	88
Table 13: Summary of evaluating proximity detection and alert technology	107
Table 14: Benefits and limitations of candidate proximity detection technologies	108
Table 15: Statistical analysis of the alert measurements for the asphalt paver	117
Table 16: Statistical analysis of proximity alert range for various pieces of construction equipment	121
Table 17: Sample output data of recorded proximity breaches	124
Table 18: Analysis of recorded relative distances or levels for alerts (unitless) of the field trials	125
Table 19: Semi-passive PPU orientations mounted on top of a hard hat	139
Table 20: PPU orientation summary on the hard hat	140
Table 21: Results of PPU trials	142

Table 22: System alert zones and methods	152
Table 23: Statistical analysis of horizontal alert distance measurements	155
Table 24: Statistical analysis of horizontal alert distance measurements	158
Table 25: Components of the testing method for proximity detection and alert systems	161
Table B.1: Summary of plan view asphalt paver operator visibility	180
Table B.2: Summary of front/rear view asphalt paver operator visibility	180
Table B.3: Summary of side view asphalt paver operator visibility	180
Table B.4: Summary of plan view excavator operator visibility	181
Table B.5: Summary of front/rear view excavator operator visibility	181
Table B.6: Summary of side view excavator operator visibility	181
Table B.7: Summary of plan view vibratory roller operator visibility	182
Table B.8: Summary of front/rear view vibratory roller operator visibility	182
Table B.9: Summary of side view vibratory roller operator visibility	182
Table B.10: Summary of plan view forklift operator visibility	183
Table D.1: Semi-passive tag orientation mounted on the side of a hard hat	191
Table D.2: Semi-passive tag orientation mounted on the front of a hard hat	192
Table D.3: Semi-passive tag orientation mounted on the back of a hard hat	192
Table D.4: Semi-passive tag orientation mounted on the front torso of a safety vest	193
Table D.5: Semi-passive tag orientation mounted on the back torso of a safety vest	193
Table D.6: Semi-passive tag orientation mounted on the side shoulder of a safety vest	194
Table D.7: Semi-passive tag orientation mounted on the top shoulder of a safety vest	194
Table D.8: PPU orientation summary on the safety vest	195

LIST OF FIGURES

	Page
Figure 1: OSHA TRIR per year for construction companies	7
Figure 2: Heinrich's Safety Pyramid	9
Figure 3: Construction fatalities caused by contact with objects or equipment	12
Figure 4: Cause of fatalities per year of CII members	13
Figure 5: Research framework	25
Figure 6: Research methodology flowchart for near miss reporting	41
Figure 7: Initial interview project location, cost, duration, and number of workers	44
Figure 8: Near miss reporting program cycle	49
Figure 9: Near miss process information flowchart	53
Figure 10: Near miss reporting form for the database template	57
Figure 11: Sample user interface of the near miss reporting evaluation tool	62
Figure 12: Scoring interface for the near miss reporting evaluation tool	63
Figure 13: Selected skid steer loaders for the study	70
Figure 14: Laser scan measurement of the interior of an equipment cabin	71
Figure 15: Reading the plan view diagram	76
Figure 16: Reading the side view diagram	76
Figure 17: Plan view of laser scan data for different skid steer loader models	79
Figure 18: Rear and front view of laser scan data for different skid steer loaders	81
Figure 19: Side view of laser scan data for different skid steer loaders	82
Figure 20: GPS based proximity warning technology	97
Figure 21: Magnetic marker field generated on the worker and by the equipment	99
Figure 22: Radar based proximity detection system for a haul truck	101

Figure 23: Rear-mounted camera and on-board screen to cover rear blind spots	103
Figure 24: Ideal case including open, unobstructed flat surface (left), Vehicle and obstructions influence of signal propagation	105
Figure 25: Alert scenarios flowchart for proximity detection and alert systems	114
Figure 26: Coverage area experimental test bed	115
Figure 27: Mounting positions for personal protection device (left), installing antenna on equipment (right)	116
Figure 28: Active proximity warning zone for a specific alert range	118
Figure 29: Mounting position of an EPU antenna on the forklift (left); a second EPU antenna mounting position on the forklift (right)	119
Figure 30: Measurement of the alert distance	119
Figure 31: Forklift proximity warning zone for a calibrated alert range	120
Figure 32: Box plot of proximity detection distance for each PPU	122
Figure 33: Proximity detection and alert system: EPU (left) and PPU (right)	135
Figure 34: PPU position and orientation test bed	136
Figure 35: PPU mounted on a hard hat in the vertical position (left) and the horizontal position (right)	137
Figure 36: PPU orientation in relation to the EPU antenna and ground surface	138
Figure 37: Test method (left) for measuring RF signal strength and results (right)	147
Figure 38: Magnetic field shells projected from the EPU (left), and signal strength measurements of a magnetic field proximity detection and alert system (right)	148
Figure 39: Mounting position of EPU (left), PPU held by test person (right)	151
Figure 40: Test bed for static equipment and mobile ground worker by test person (right)	153
Figure 41: Active proximity warning zone for PPU alert	156
Figure 42: Mobile equipment and static worker experiment (left); boxplot of proximity alert distances (right)	157

Figure 43: Mobile equipment and static worker obstructed PPU experiment (left); boxplot of proximity alert distances (right)	159
Figure 44: Mobile equipment and mobile worker experiment	160
Figure A.1: Near Miss/Unsafe Condition Reporting Form	175
Figure A.2: Near Miss Database Report Query	176
Figure B.1: Asphalt paver plan view of laser scan data	179
Figure B.2: Excavator plan view of laser scan data	180
Figure B.3: Vibratory roller plan view of laser scan data	181
Figure B.4: Forklift plan view of laser scan data	182
Figure C.1: Grader proximity warning zone for a specific calibrated alert range	185
Figure C.2: Excavator proximity warning zone for a specific calibrated alert range	186
Figure C.3: Truck and trailer proximity warning zone for a specific calibrated alert range	187
Figure C.4: Pick-up truck proximity warning zone for a specific calibrated alert range	188
Figure C.5: Vibratory roller proximity warning zone for a specific calibrated alert range	189
Figure C.6: Dump truck proximity warning zone for a specific calibrated alert range	190

LIST OF SYMBOLS AND ABBREVIATIONS

2D	Two-Dimensional
3D	Three-Dimensional
Airprox	Aircraft Proximity Hazard
AIT	Augmented Inspection Team
ARTTS-NMA	Autonomous Real-Time Tracking System of Near Miss Accidents
BLS	Bureau of Labor Statistics
CAA	Civil Aviation Authority
CAD	Computer Aided Design
CCTV	Closed Circuit Television
CDC	Center for Disease Control
CII	Construction Industry Institute
DHS	Department of Homeland Security
EMT	Emergency Medical Technician
EPU	Equipment Protection Units
EU	European Union
FACE	Fatality Assessment and Control Evaluation
FOPS	Falling Object Protective Structures
FOS	Field-of-Signal
FOV	Field-of-view
GMR	Giant Magnetoresistive
GPS	Global Positioning System
HASARD	Hazardous Area Signaling and Ranging Device
IAFC	International Association of Fire Chiefs

IIT	Incident Inspection Team
IMPACT	Industrial Hygiene Metrics and Reporting Procedure
ISO	International Organization for Standards
ITC	Internal Traffic Control
JHA	Jobsite Hazard Analysis
LED	Light-Emitting-Diode
LF	Low Frequency
LOS	Line-of-sight
MORS	Mandatory Occurrence Reporting Scheme
NIOSH	National Institute for Occupational Safety and Health
NRC	National Regulatory Commission
OSHA	Occupational Safety and Health Administration
PPE	Personal Protection Equipment
PPU	Personal Protection Units
RADAR	Radio Distancing and Ranging
RB	Rectangular Box
RF	Radio Frequency
RFID	Radio Frequency Identification
ROPS	Rollover Protective Structures
RSSI	Received Signal Strength Indication
RTS	Robotic Total Station
SIT	Special Inspection Team
TRIR	Total Recordable Incident Rate
UCS	Union of Concerned Scientists
UHF	Ultra High Frequency

U.S.	United States
UWB	Ultra-Wideband
VHF	Very High Frequency
VLF	Very Low Frequency
VTC	Visibility Test Circle
VTP	Visibility Test Person

SUMMARY

The U.S. construction industry continues to rank as one of the most dangerous work environments when compared to other industrial sectors. Construction companies are required to record and report lagging safety leading indicators including fatalities, injuries, and illnesses. Safety leading indicators provide an opportunity to identify construction site hazards and hazardous worker behavior before a fatality, injury, or illness occurs. Further improvements are also necessary for construction safety through the use of technology. The application of advanced or emerging technologies can have a significant role in enhancing construction worker safety performance.

This research seeks to report and analyze safety leading indicators, specifically near misses. Furthermore, technologies capable of providing alerts in real-time to construction equipment operators and ground workers during hazardous proximity situations are reviewed. A testing method for proximity detection and alert devices for the construction environment is presented. Operator visibility, including impacts of design components, is also measured and analyzed.

One major contribution of this research is the creation of a near miss reporting program ready for implementation for construction companies. Other research contributions include understanding of impacts of design on operator visibility, scientific evaluation data of proximity sensing technology, and a test method for proximity detection and alert system deployed in the construction environment. Research deliverables can be disseminated for improved construction worker safety education and training.

CHAPTER 1

INTRODUCTION

The intent of this chapter is to introduce an overview on the status of worker safety performance in the U.S. construction industry. Research needs are derived from the background review and identified in this section. The motivation of the research is discussed as well as an introduction to the identified research needs statement. The scope of the research and statement of contributions are also presented. This chapter concludes with an outline of the thesis.

1.1 Overview

The construction industry employed approximately 5.8 million workers in 2013 which accounted for 4% of the total U.S. employed workforce [1]. In the same year, the construction industry recorded approximately 747,562 establishments [2]. The number of fatalities experienced by the construction industry has been on the decline, but has stagnated in recent years [3]. Since 2003, the construction industry averages approximately 1,010 fatalities per year. Although the number of fatalities experienced has declined, the percentage of fatalities when compared to the total U.S. workplace fatalities remains close to 19% each year [4]. This percentage of workplace fatalities is much higher than the 4% employment the construction industry has of the U.S. workforce. The Center for Disease Control (CDC) and Prevention reported that construction fatalities resulted in approximately \$10 billion worth of loss due to direct and indirect costs between 1992 and 2002 [5]. This study also reported the average cost of each construction fatality during that time period was \$864,000 [5]. Likewise, the National Safety Council (NSC) estimated a cost over \$10 billion for fatal and non-fatal

construction industry is 2008 [6]. In 2007 alone, the cost of fatal and non-fatal injuries cost the industry approximately \$6 billion and \$186 billion respectively [7].

1.2 Motivation

This research aims to enhance the measurement and understanding of safety performance by workers on construction sites. Because construction is one of the leading industries for workplace fatalities, methods to improve safety performance measurement or understanding are needed. A majority of construction safety performance measurement strategies currently assess lagging indicators which are measurement criteria based on reactive measures (primarily after an accident occurs). These lagging indicator safety measures are reported by construction companies to the Occupational Safety and Health Administration (OSHA) on a periodic basis [8]. Lagging indicators are often measured in units of lost workday, number of injuries, or fatality rate. The major limitation to this form of safety measurement performance is that accidents must occur before hazards or unsafe worker behavior can be identified and addressed.

Another form of safety measurements called leading indicators pro-actively measure safety performance by measuring processes, activities, and conditions that define performance can predict future results [9]. One such safety leading indicator is a near miss which is defined by the U.S. Department of Labor as an incident where no property damage and no personal injury were sustained, but where, given a slight shift in time or position, damage and injury easily could have occurred [8]. An advantage of measuring leading indicators is that data can be generated and analyzed without the requirement of an illness, injury, or fatality to occur.

By collecting safety leading indicator data, many possibilities become available for enhanced construction site safety [10][11]. Alerts can be provided to workers when safety leading indicators are identified (such as when ground workers are in too close

proximity to construction equipment) to potentially avoid accidents. By implementing technology as a means to identify, record, and alert construction site personnel, it can serve as an additional layer of safety protection for construction site personnel.

Hazardous proximity situations between ground worker and construction equipment accounted for 17% of construction fatalities in 2012 [12]. Current safety practices for hazardous proximity situations have proven inadequate for preventing worker fatalities and injuries. Safety leading indicators, specifically near misses, can provide a supplemental method of measuring worker safety performance with regards to this issue. Furthermore, sensing technology can be implemented to reliably provide alerts to ground workers and equipment operators during these hazardous situations.

The primary subject matter of this thesis is the following:

Creating and implementing a near miss reporting program for construction companies for recording, measuring, and analyzing near miss data from construction sites and implementing technology as an additional layer of safety protection for safety leading indicators - specifically hazardous proximity situations through operator visibility measurement and sensing technology to reliably detect, alert, and record hazardous events so that safety measurement practices can be enhanced and further understanding of construction safety best practices is possible.

1.3 Contributions and Impact

The primary focus of this research is capturing and utilizing active safety leading indicator data for enhanced construction safety. Construction safety standards currently measure safety performance on lagging indicators which require loss to the construction industry including worker injuries, illnesses, and fatalities as well as loss in productivity and financial losses through medical costs, worker's compensation, and litigation. Safety

leading indicators can potentially transform the way construction site personnel, specifically safety managers, measure and analyze worker safety performance. The major contributions of this research are the following:

- A near miss reporting program including best practices for reporting, analyzing, and disseminating near miss information. This program includes guides for implementation into a construction company and potential barriers associated with reporting near misses.
- A testing method is created to evaluate the reliability and effectiveness of proximity sensing technology for detection and alerts during hazardous proximity situations between ground workers and construction equipment.
- Scientific experimental evaluation data of proximity sensing technology when deployed in a simulated construction environment including coverage area measurement, performance during several human-equipment interaction scenarios measurement, and personnel interview data
- Operator visibility measurement and analysis including visibility maps for various pieces of construction equipment

Methods of measuring and benchmarking construction safety performance are one impact of this research. By reporting and analyzing near misses on construction sites, safety information of potentially hazardous areas can be disseminated through worker safety education and training to increase safety awareness. This research also allows for real-time decision through alerts during hazardous proximity situations between ground workers and construction equipment. Research deliverables including operator visibility maps and sensing technology coverage areas can be used for enhanced worker education and safety training.

1.4 Thesis Organization

This thesis aims to investigate safety leading indicators for construction safety by creating a near miss reporting program and implementing technology for an additional layer of protection for workers during hazardous proximity situations. Table 1 provides a brief description of the contents of each chapter.

Table 1: Title and description of each thesis chapter

Chapter	Description
1) Introduction	This chapter introduces aspects of the construction industry and focuses on safety. A motivation for research is presented as well as research contributions and impacts.
2) Background	This chapter provides a review of construction industry accident statistics including accident statistics resulting from hazardous proximity situations and limited construction site visibility. Active safety leading indicators are presented and discussed as well as the research focus and needs statement.
3) Research Hypothesis and Methodology	The hypothesis and objectives are presented in this chapter as well as the scope for the research. A framework of the research methodology is also presented.
4) Near Miss Reporting for Construction Safety	This chapter presents a near miss reporting program for implementation into a construction company. The program provides a method for reporting and analyzing near misses as well as disseminating information into worker safety education and training.
5) Equipment Operator Visibility	Laser scanning technology is used to capture areas that are invisible to construction equipment operators in this chapter. Four models of skid steer loaders are measured to understand how components of equipment design impact operator visibility.
6) Selection of Technology	This chapter presents evaluation data of several technologies thought to be capable of providing alerts in real-time to construction personnel during hazardous proximity situations.
7) PPU Position and Orientation	Proximity detection and alert systems using Ultra-High Radio Frequency (RF) technology were evaluated specifically for position and orientation of system components when deployed in test beds designed to emulate typical construction site environments.
8) Test Method for Proximity Sensing Technology	A test method is created to evaluate existing proximity detection and alert systems for functionality when implemented on a construction site. Several experimental trials are designed and performed on a proximity detection and alert system.
9) Conclusions	This chapter summarizes the research findings and concludes the thesis. Future research extensions and opportunities of this research are discussed as well as limitations.

CHAPTER 2

BACKGROUND

The construction industry continues to experience a high number of workplace fatalities and injuries when compared to other U.S. industry sectors. Much research has been performed in construction safety in an attempt to enhance worker safety performance. The following background review discusses construction industry accident statistics, safety leading indicators including near misses, human-equipment interaction on construction sites, and construction site visibility. A research needs statement and statements regarding the research focus are derived from findings of this background review and presented at the end of this section.

2.1 Construction Industry Accident Statistics

Since the enactment of the Occupational Safety and Health Act of 1970, construction companies are required to report all fatalities, injuries, and illnesses that occur during or as a result of the work environment [13]. Reported accidents are categorized into the following: 1) Occupational fatality or 2) nonfatal injury or 3) illness. Both of these categories result from a worker becoming fatality wounded, injured, or ill from an event or exposure in the work environment. The U.S. Bureau of Labor Statistics (BLS) analyzes accident data submitted by construction companies [8].

The U.S. construction industry experiences one of the highest worker fatality rates per year when compared to other industries. A study completed in 2012 reported the construction industry accounted for 18% (775 fatalities) of the nation's workplace fatalities [14]. In an attempt to normalize safety performance between construction

companies, OSHA employs the Total Recordable Incident Rate (TRIR) which uses a base of 200,000 cumulative worker hours for the ratio [15]. Figure 1 shows the average construction industry TRIR compared to construction company participants of the Construction Industry Institute (CII). Although Figure 1 shows improvements in safety performance from 1989 to 2011, safety improvements within the construction industry have been minimal since 2008 [16].

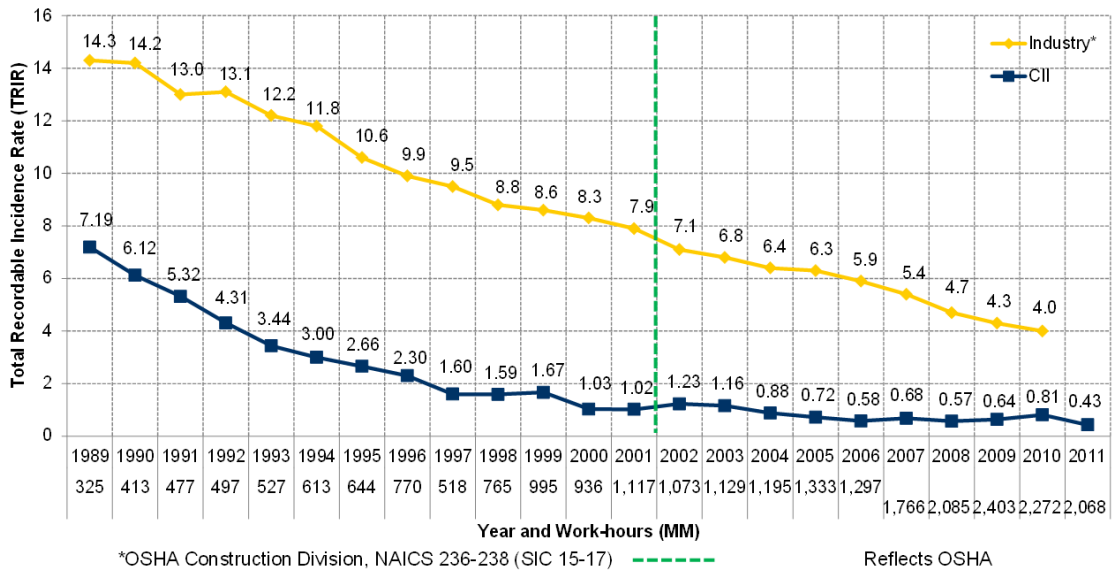

Figure 1: OSHA TRIR per year for construction companies [16]

In 2011, the BLS recorded that for every 10,000 workers, there were 117 recordable cases where the injury or illness was nonfatal and required days away from work. These numbers were almost identical to the previous year. A direct function of severity of injury or illness is the number of days away from work due to the injury or illness. For 2011, the median number of days missed due to injury or illness was eight, the same value as 2010 [17].

Worker injuries on construction sites also present safety concerns for the construction industry. These types of accidents negatively impact the success of a

construction project through lost work time, increased medical costs, and decreased productivity. In 2012, the construction workers experience 179,100 non-fatal injuries [18]. This number was slightly lower than the 184,700 injuries reported for the construction industry in 2011. All reported injuries and illnesses values are limited to accidents involving personnel to be absent from work as a result of the injury [4]. Table 2 shows a summation table of non-fatal injuries recorded by the construction industry per year [4]. Values in parentheses represent the percentage of cases when compared to the total non-fatal injuries experienced by the U.S. private industry sector.

Table 2: Non-fatal injuries of the construction industry [18]

Year	Total
2012	179,100 (6.0%)
2011	184,700 (8.6%)
1992- 2010	3,153,701 (10.6%)

2.2 Safety Leading Indicators

Construction companies are currently required to document work-related accidents resulting in injury and illness of employees [4] which are classified as lagging indicators because the measurement occurs after an accident occurs. Historically, safety performance is determined by lagging indicators such as number of illnesses, injuries, or fatalities that result from an unsafe act or hazard [13]. Safety lagging indicators are unable to reflect if a hazard has been mitigated, the potential severity of an event, or the event causation [19][20]. Unlike lagging indicators, safety leading indicators (including near misses) are measurements of processes, activities, and conditions that define performance and can predict future results [9][21][22][23]. Examples of safety leading indicators include behavior based safety [24][25][26][27], jobsite hazard analysis

[28][29], and safety training [30][31][32][33]. One such safety leading indicator is a near miss which is defined by the U.S. Department of Labor as an incident where no property damage and no personal injury were sustained, but where, given a slight shift in time or position, damage and injury easily could have occurred [8]. Other industries, such as manufacturing, have adopted these terms for other purposes including describing upstream and downstream processes [34]. Currently, neither the U.S. Department of Labor nor OSHA collect and analyze safety leading indicators including near miss data [35].

The Safety Pyramid created by Heinrich shown in Figure 2 illustrates that a multitude of minor incidents are required for one major incident to occur, and even more near misses should occur for some minor incidents [36]. The major incidents (including worker fatalities), minor incidents (including injuries and illnesses), and near misses (including hazardous behavior and conditions) are work-related. For example, an illness could result from exposure to a hazardous chemical on the construction site. An example of a near miss related to work-related illness would be a worker being exposed to a hazardous chemical but not contracting an illness.

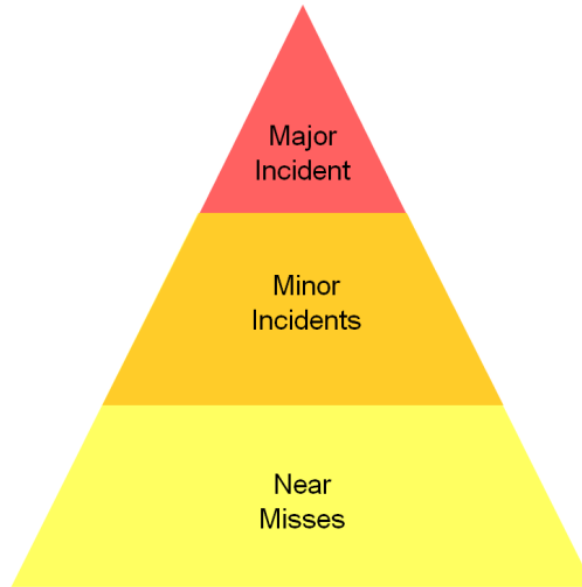

Figure 2: Heinrich’s Safety Pyramid [36]

The Safety Pyramid provides a motivation to reduce the number of actual accidents by identifying accidents that had potential to occur. Derived theories from the Safety Pyramid including the Domino Theory and the Loss Causation Models are categorized as linear causation models by many safety theorists [37] which suggest that accidents are results of a sequence of events. Several modifications and augmentations have been applied to the original safety pyramid including “incidents without damage or loss” and “unsafe hazards and conditions” [38]. This supports previous research efforts claiming that all serious injury to workers can be successfully prevented through zero injury techniques [39][40][41][42].

Leading indicators are measurements of processes, activities, and conditions that define performance and can predict future results [43]. These measurements can provide locate and provide guidance on where corrective interventions are necessary. A leading indicator is the result of periodic measurements of a specific safety performance. Leading

indicators provide opportunities for safety managers to identify areas of safety performance that need improvement before injuries are sustained [44].

Near misses are categorized as a type of safety leading indicator. Because near misses require a meaningful or actionable metric, they are further categorized as an active safety leading indicator and must be quantifiable. Near miss incidents are typically not reported in terms of hours or worker exposure, but rather as single events or instances [45][46]. By recording near misses, construction workers can be educated on strategies to prevent future accidents [47]. Near misses meet or exceed requirements of defining an actionable leading metric [43]:

- Data must be numeric
- Data must be easily understood
- Data must be perceived as credible
- Data must signal the need for action
- Data must be related to other indicators
- Data must not generate unintended consequences

Any safety leading indicator should create a consistent measurement procedure such that data recorded is meaningful. A developed measurement process includes: 1) personnel knowledgeable about the process to be measured, 2) personnel trained to collect information and data in a consistent fashion, 3) a defined methodology for information and data collection, 4) a defined frequency and schedule for information and

data collection, 5) tools formatted for the consistent collection of information and data, and 6) a repository for the information and data.

2.3 Human-Equipment Interaction

Of the construction fatalities experienced in 2012, 17% (135 fatalities) resulted from workers being struck-by an object or piece of construction equipment. In 2011, the Bureau of Labor Statistics reported 122 fatalities resulting from collisions between construction personnel and equipment or objects. These fatalities account for 17% of all fatalities experienced by the construction industry in 2011 and 2.5% of the total fatalities experienced by the U.S. private industry sector [48]. Since 2003, the construction industry has averaged 192 fatalities resulting from construction equipment or other objects striking workers per year [4]. These fatalities resulting from workers being struck represented 3% of the totally workplace fatalities experienced in 2012 by the U.S. private industry sector [48]. Figure 3 shows the total construction fatalities and those caused by ground worker contact with objects or equipment between 2003 and 2012 [48].

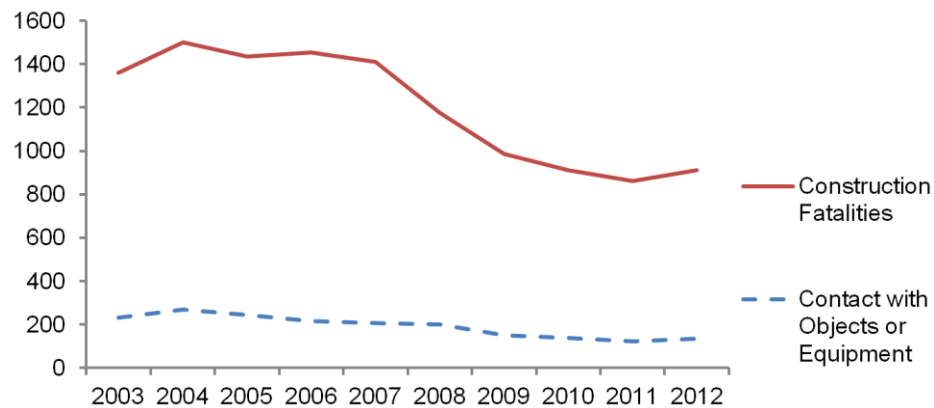

Figure 3: Construction fatalities caused by contact with objects or equipment [48]

A longitudinal study identified minimal significant change over time between fatalities caused from contact collisions between construction equipment and ground workers between 1985 and 2009. Although the number of fatalities resulting from contact collisions decreased during this time frame, the percentage when compared to total construction fatalities remained consistent [49]. Approximately 33% of workers fatalities caused by contact collisions on construction sites were struck by construction equipment. Even in highway work zones, more worker fatalities are caused by struck-by events from pieces of construction equipment rather than commuting vehicles [50]. Members of the CII also reported a significant portion of their worker fatalities were caused by struck-by incidents as shown in Figure 4.

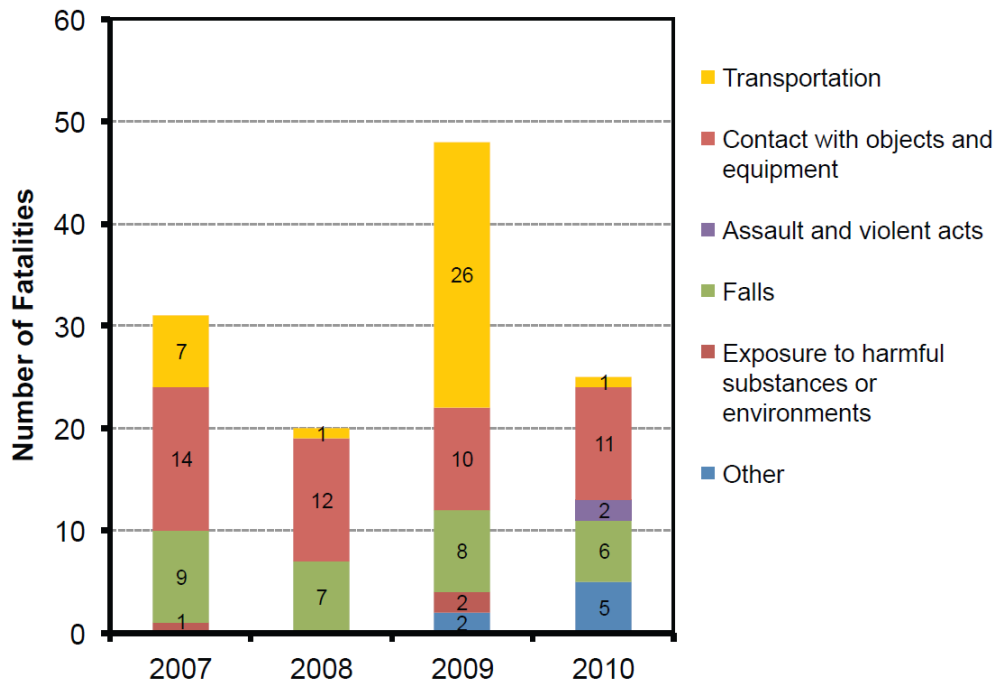

Figure 4: Cause of fatalities per year of CII members [51]

In 2012, the Bureau of Labor Statistics found the private sector of the construction industry reported 18,072 injuries caused by ground workers colliding with construction

equipment or other objects [4][52]. These injuries represent 10% of all the construction worker injuries in that year. The injuries caused by struck-by incidents in 2011 comprised 15% of the total injuries experienced by the construction industry that year (26,690 injuries).

Various research efforts have attempted to better understand risks to workers on construction sites [53][54], specifically hazardous proximity situations between construction workers and equipment. Harsh outdoor environmental characteristic of construction sites integrated with the repetitive nature of construction tasks have been found to cause workers to lose focus and awareness of their surroundings [55][56]. One study claimed the actual cause of proximity issues are neither being properly examined nor recorded. If the information is recorded, important details of the incident are not included [57]. This study further identified two general problems resulting in proximity issues between construction equipment and workers in the industry:

- 1) Workers and equipment operators: Outdated or never implemented policies, a lack of knowledge of existing specific risk factors, and repetitive work tasks
- 2) Incident investigation: All incident causation data is collected after-the-fact resulting in no or limited real-time incident information.

Other research efforts focused on strategies for prevention of hazardous proximity situations on construction sites. Preventative measures include implementing a construction equipment maintenance checklist and internal traffic control (ITC) plans specific to each project [55] or path planning for equipment [58]. The ITC plan is created

during the planning phase in an attempt to limit turning or reverse movements of construction equipment. Management tools have also been created to pro-actively prevent struck-by falling objects on construction sites [59] as well as attribute-based risk analysis methods to identify potential struck-by hazards in design models [60].

2.4 Equipment Operator Visibility

Visibility related issues have an impact on the overall safety of the construction industry. One of the leading causes of contact collisions between construction equipment and workers are blind spots [57][61]. Blind spots are a product of poor visibility in which an equipment operator's line-of-sight is impeded by components of the construction equipment.

The close proximity of workers on the ground to heavy construction equipment creates many visibility-related issues for operators. Blind spots restrict an operator's line-of-sight to objects outside of the construction equipment cabin. Many accident investigations and research studies found visibility-related issues created by blind spots caused operators to: 1) run over workers and materials, 2) contact other equipment, and 3) rollover construction equipment [62].

2.4.1 OSHA Fatality Database Review

OSHA maintains a database of construction worker fatalities showing the major causes of each fatality [35]. Data from 1990 to 2007 was extracted from this database and grouped into categories for further analysis [62]. The investigation was completed to determine the impact visibility-related issues have on construction fatalities.

The database provided 13,511 case descriptions for all the fatalities recorded over the time period. The descriptions were examined, and specific visibility information was recorded for evaluation. The study found that of the fatal cases studied, 659 fatalities were caused by some type of equipment- related visibility issue. The researchers focused on 594 of the 659 visibility related fatalities that involved some type of construction equipment.

The 594 visibility related fatalities were divided further into these five categories: 1) Workers being struck by moving equipment parts, 2) material being lowered by the equipment, 3) electrocutions caused by construction equipment striking electric power lines, 4) equipment rollovers, and 5) fatalities from workers drowning after construction equipment rolled into a body of water. The study found that 87.7% of the construction equipment fatalities caused by visibility issues were the result of workers being struck by moving construction equipment. 5.1% of the visibility related fatalities were attributed to construction equipment roll-over, 3.4% were caused by a worker being struck by part of a piece of construction equipment or material, 2.5% resulted from electrocution and 1.3% were the outcome of workers drowning after an equipment roll-over [62].

The findings of this study indicated that blind spots created many visibility-related problems for construction equipment personnel and ground workers. Of all the fatalities reviewed, 4% cited some type of visibility-related issue as a major factor in the incident, and 82 fatalities cited visibility-related issues as the direct cause of the fatality. Blind spots were specifically cited in 56.1% as the main cause of the incident. Other visibility-related issues discussed were obstructions and adverse lighting conditions including situations in which the light was too bright (glare) or too dark. Further analysis

of the data showed that depending on equipment type, up to 87% of visibility-related construction equipment fatalities were not predictable by either operator or worker. In summation, the chances to survive contact with construction equipment are minimal.

2.5 Focus

Fatalities and injuries continue to plague the construction industry. Construction companies suffer financial loss, productivity loss, and immeasurable loss such as emotional or crew moral when accidents occur [64][65][66][67]. A portion of accidents occur because of the limited working space available on construction jobsites. Ground workers are often required to work in close proximity to heavy construction equipment in the harsh construction environment [68]. The potential for near misses and contact collisions between construction resources is high and can compromise the safety and health of construction workers.

Approximately two-thirds of construction companies currently have active safety programs [69]. Typically, safety programs are implemented within a specific construction company [70][71][72][73] to enhance safety performance of workers. This is achieved through strategic modification of an existing safety policy [74], hazard identification and analysis [75][76][77], prevention through design [78][79][80], risk mitigation [81][82][83], scheduling and planning [84][85], safety training, and many other methods to ultimately positively impact the company's safety culture [86][87][88][89][90]. Research and existing practices for hazardous proximity situations in the construction industry are currently lacking in the following areas:

- Scientific evaluation data for safety technologies in construction
- Minimal information exists on how to successfully implement and utilize proximity detection and alert technologies in construction
- Equipment operator visibility data near miss incident data and risk management analysis have not be integrated to evaluate hazardous proximity situations
- A method for recording and analyzing safety leading indicator data (specifically near misses)

This research focuses on the reporting, recording, analyzing, and providing real-time alerts for safety leading indicator data, specifically near misses. This research aims to understand strategies to measure and analyze safety leading indicator data for enhancing worker safety performance by limiting frequency and duration of hazardous situations. Existing performance metrics for construction safety have proven inadequate for preventing worker fatalities and injuries. This research aims to provide a method for utilizing safety leading indicator data by:

- Presenting a methodology for capturing, analyzing, and disseminating near miss data
- Offering guidelines and components for a company specific near miss reporting program as well as evaluation tools
- Activating reliable real-time alerts to ground workers and equipment operators in hazardous situations
- Enable individual worker safety performance monitoring without accidents
- Measuring operator visibility within an equipment cabin

CHAPTER 3

RESEARCH HYPOTHESIS AND METHODOLOGY

The research methodology and framework for safety leading indicators of proximity hazards between heavy construction equipment and workers is presented in this chapter. Statements of the research hypothesis, objectives, and scope are discussed as well as an overview of the research framework. The remaining sections within the chapter review the various phases of this research including near miss reporting in construction, operator visibility measurement and analysis, evaluation of technology for proximity sensing, position and orientation of proximity detection and alert system components, and a test method for proximity detection and alert systems.

3.1 Introduction

The overall goal of this research is to build and evaluate a framework measuring the safety performance of workers during construction operations through active safety leading indicators. The overall research methodology is categorized into three sections as shown in Table 3.

Table 3: Categorization of research methodology sections

Section	Description	Goal
Near Miss Data Collection	Construction site personnel identify and report near miss events	Gather and analyze active safety leading indicators to generate knowledge for improved worker safety education and training
Operator Visibility Awareness	Measure and analyze visible and non-visible areas for equipment operators	Capture and assess operator visibility to enhance operator awareness of potentially hazardous areas around construction equipment and improve equipment design for safety
Proximity Hazard Sensing	Activate alerts in real-time to affected construction site personnel during hazardous proximity situations	Detect, alert, and record potential proximity hazards between ground workers and construction equipment in real-time

The near miss data collection section intends to create a framework for a safety program within a construction company for reporting near misses, analyzing potential hazards, and disseminating gathered construction site safety information. The operator visibility awareness section aims to measure and analyze areas that are not visible for an equipment operator of a specific piece of construction equipment. Equipment operators can become educated of invisible areas around a specific piece of construction equipment for increased awareness of potential hazards. Technology is evaluated in simulated construction site operations for reliability and effectiveness of detecting, alerting, and recording hazardous proximity situations between construction operators and equipment. The performance of technology provides guidance for selection and evaluation of other systems through system component evaluation. These categories allow for enhanced awareness of hazardous proximity situations in construction as well as data collection and analysis of active safety leading indicators.

3.2 Hypothesis

Active safety leading indicators can provide a supplemental method of measuring safety performance of construction workers without experiencing workplace accidents. Knowledge generated from the collection of active safety leading indicators (such as near misses) can be used to identify potentially hazardous situations on construction sites. Sensing technology can be implemented as an additional barrier for worker safety by activating alerts during hazardous proximity situations. Proximity detection and alert systems can reliably and effectively identify, alert, and record hazardous proximity situations while deployed in the construction environment. Four research questions emerged during the initial design and development of the research framework that are essential to evaluate the stated hypothesis. The following are the research questions:

- 1) Can near misses be recorded and analyzed to increase awareness of potential hazards on construction sites?
- 2) Can operator visibility be measured and analyzed for education of equipment operators of invisible areas around construction equipment?
- 3) Are proximity detection and alert systems capable of detecting, recording, and alerting construction personnel and equipment operators in real-time of hazardous situations?
- 4) How should proximity detection and alert systems be evaluated for potential deployment onto construction sites?

3.3 Objectives and Scope

By identifying, recording, analyzing, and disseminating active safety leading indicators, an additional measurement of worker safety performance is possible. Additionally, technology can be implemented to accomplish this through real-time data collection and alerts during hazardous proximity situations. The primary goal of this research is to enhance construction site safety conditions for workers during heavy construction equipment operation. To achieve this, several necessary objectives are listed:

- Create a near miss reporting program for implementation into a construction company
- Test, measure, and evaluate the effectiveness and reliability of proximity detection technology in the construction environment
- Create a test method for evaluating the reliability of proximity detection and alert systems
- Measure and analyze the visibility of operators of specific pieces of construction equipment

The scope of this research is limited to hazardous proximity situations between construction “ground” workers (workers that primarily complete construction tasks while walking on the ground plane surface) and heavy construction equipment operating on the ground surface. The research will include private construction companies or government entities performing construction in the U.S. Information gathered from data sets of private construction companies will not contain any proprietary information. Selected

construction activities between heavy construction equipment and ground workers (human-equipment interaction) are the large majority focus of this research, although near miss reporting applies to all identified hazards on a construction site. Specific proximity hazards considered in the research included worker contact with heavy equipment on the ground surface.

3.4 Framework

The research methodology follows a framework that stems from hazardous proximity issues between construction resources and site conditions. The framework utilizes the previously mentioned three categories of research (near miss data collection, operator visibility measurement, and proximity hazard sensing) to generate and disseminate knowledge from raw data collection. Proximity issues are presented as a result of the close interaction of construction resources (labor, equipment, and materials). An overview of the research framework is provided in Figure 5. Columns of the framework detail the evaluation, analysis, deliverables, and resulting safety education and training of each research category.

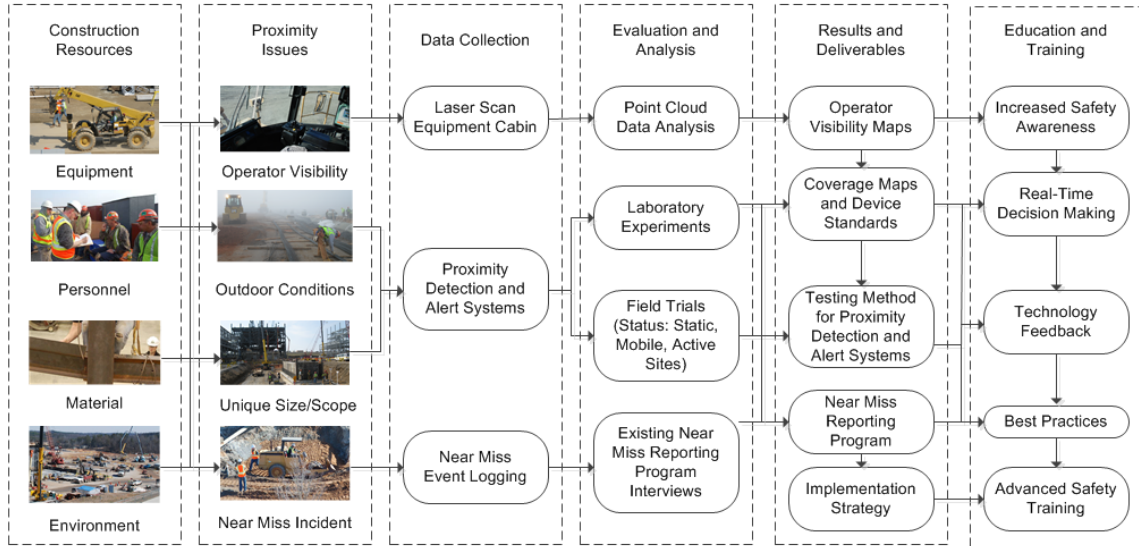

Figure 5: Research framework

The initial data collection phase of this research includes laser scanning construction equipment cabins, evaluating technologies thought to be capable of detecting and alerting construction personnel during hazardous proximity situations, and interviewing construction personnel about near miss reporting programs. Each component of the collected data was evaluated and analyzes to further guide research efforts including field trials of proximity detection and alert systems, point cloud data analysis for operator visibility, and longitudinal interviews with construction personnel with regards to near miss reporting programs.

Multiple research deliverables resulted from the evaluation and analysis of collected data. Operator visibility maps for select pieces of construction equipment, coverage area maps for proximity detection and alert systems, components of a testing method for proximity detection and alert systems, and a near miss reporting program

were created based on results of the data analysis and evaluation. Suggestions for implementation of research deliverables is also discussed in each subsequent section.

3.5 Near Miss Reporting Program

Chapter 4 presents a near miss reporting program that can be implemented in a construction company, government entities that require construction, or construction industry organizations. The program was created based on interview data of construction personnel that participate in near miss reporting programs. The research also investigated near miss reporting programs in other industry sectors including aviation, healthcare, and manufacturing. Components of a near miss reporting program, such as a near miss reporting template, program evaluation tool, and reporting best practices, are discussed. The created near miss reporting program was implemented on existing construction projects and periodically monitored for four months during normal construction operations. Findings of the periodic review were used to further modify the created near miss reporting program. This work is located in Chapter 4.

3.6 Operator Visibility Measurement

After reviewing and creating a near miss reporting program for all near misses, the next logical step is to focus specifically on select leading indicators for potential mitigation of hazards and increase in worker safety performance. One such safety leading indicator is operator visibility. This portion of the research strives to measure operator visibility as a safety leading indicator and identify potential areas for near misses around pieces of construction equipment.

One identified cause of contact collisions between ground workers and construction equipment is limited equipment operator visibility. By measuring operator visibility, equipment operators can increase their awareness of limited or non-visible areas around a specific piece of construction equipment. This research is discussed in detail in Chapter 5. A spatial point cloud was generated by using a three-dimensional (3D) laser scanner to scan the interior and exterior of an equipment cabin. The point cloud was analyzed for percent visibility and visible areas versus invisible areas to an equipment operator. Several pieces of construction equipment were measured for areas visible and invisible to an equipment operator. Four models of one piece of equipment were measured to demonstrate how construction equipment design impacts operator visibility. Design characteristics that improved operator visibility were identified through the data analysis efforts.

3.7 Technology Evaluation

Another safety leading indicator for construction site safety performance is distance between ground workers and construction equipment. Furthermore, technology can be used to detect, record, and analyze near misses with regards to ground workers being in too close proximity to construction equipment.

Existing wireless remote sensing technologies can potentially allow real-time decision making for construction site personnel with regards to safety. Because construction sites are dynamic environments often requiring construction resources to interact in limited space, providing alerts in real-time to construction site personnel during hazardous conditions could enhance safety performance. The research presented

in Chapter 6 identifies technologies thought to be capable of providing alerts during hazardous proximity situations as well as recording events for further analysis. Candidate technologies identified through background review efforts were further evaluated through laboratory and field tests. Proximity detection and alert systems were deployed in simulated construction site environments to evaluate the system's ability to perform in the harsh construction environment. Further testing including position and orientation of system components of a selected technology is presented in Chapter 7.

3.8 Testing Method for Proximity Detection and Alert Systems

Human-equipment interaction on construction sites contribute negatively to construction safety across the industry. Scientific evaluation data is currently lacking for proximity detection and alert systems intended for use in the construction industry. Based on the background review of technologies thought to be capable of providing real-time alerts during hazardous proximity situations, a testing method was created to provide a standard for evaluating proximity detection and alert systems. Chapter 8 presents components of the testing method that incorporates various combinations of static and mobile construction equipment and ground workers to measure the system's alert distance and repeatability. The test method proscribes a coverage area experiment that evaluates the alert distance of the system from several worker approach angles. False positive and false negative alerts are also identified and used to analyze a specific proximity detection and alert system.

CHAPTER 4

NEAR MISS REPORTING PROGRAM FOR CONSTRUCTION

SAFETY

Leading indicators for safety can provide an additional metric for assessing worker safety performance on construction sites. Near misses are one such safety leading indicator that can identify hazardous behaviors and conditions on construction sites. A near miss reporting program for construction companies is presented in this chapter. The program was created from results of construction site personnel interviews and other U.S. industry sectors that utilize near miss reporting. Components of the program include near miss reporting guidelines, a database template for reporting and analysis, and a program evaluation tool for periodic review by safety managers. Near miss reporting enables safety managers and other construction site personnel to identify hazards before an accident occurs through the investigation and analysis of reported near misses.

4.1 Introduction

By recording and analyzing near misses on construction sites, an additional metric for safety performance becomes available for construction companies [91][92][93]. Safety managers and other site personnel can identify hazardous conditions and worker behavior before an accident occurs through reporting and investigating near misses. Near miss information can equip safety managers to identify and mitigate hazardous issues which enable pro-active worker safety training and education.

A background review of near miss reporting programs both in the construction industry and other U.S. industry sectors was completed. Results of the background review were used to create an interview tool deployed on multiple classifications of

construction site personnel. Best practices of near miss reporting were identified through the background review effort and results of the construction site personnel interviews. These best practices were categorized into various sections and served as guidelines for a near miss reporting program. This program can be fully implemented into a construction company, or individual components can be adopted by companies with an existing near miss reporting program. The created near miss reporting program achieves the following:

- Creates an actionable definition of a near miss
- Demonstrates how reporting can be a positive experience for all construction personnel
- Describes how near miss data can be effectively collected, analyzed, and managed

A set of interview questions for various construction site personnel were created based on the results of the literature review. These questions can be viewed in Appendix A of this report. The objective of the initial interviews was to identify benefits and limitations to specific near miss reporting programs currently utilized by construction companies. Results of the literature review and the initial interview provided the required data to create near miss reporting program guidelines. The created guidelines were implemented on active construction sites and monitored periodically for four months. The periodic reviews of projects with implemented near miss reporting guidelines revealed barriers that were addressed in the near miss reporting guidelines. Several research deliverables such as program evaluation tools and a database template were created to supplement the near miss reporting guidelines.

4.2 Background

A review of various aspects of near miss reporting is discussed in this section. Specifically, the definition of a near miss, near miss data collection, near miss reporting methods, and near miss reporting programs implemented in other U.S. industry sectors are all discussed. Many of the findings from the literature review were incorporated into the created near miss reporting program for construction companies.

4.2.1 Near Miss Definitions

The reviewed literature indicated that definitions of a near miss vary across individual companies and across industries. The difference in definitions reveals the challenge of accurately defining a near miss across any industry. Many attempts have been made to define a near miss including:

- A potential to, but does not result in harm [94]
- An instantaneous event which resulted in the sudden release of energy and had the potential to generate an accident [47]
- An event that signals system weaknesses that if not remedied, could lead to significant consequences in the future [95]
- An event that leaves no injuries or property damage or evidence that they occurred [96]
- An incident or unsafe condition with potential for injury or property damage [97]

Bechtel, a large construction corporation, defines a near miss as “an incident in which a condition exists or an act was carried out that had the potential for injury,

property damage, environmental release, or an adverse health exposure to take place. Because of various circumstances, the potential injury or exposure did not occur, but the potential was recognized” [98]. At British Petroleum’s Toledo refinery, a near miss is defined as “an unplanned event where no loss occurs, but given a different set of circumstances, an actual loss through injury, damage to assets, environmental harm, or business interruption could have occurred” [99]. A near miss analysis report written by the Wharton School Center for Risk Management and Decision Processes define a near miss as an event that signals a system weakness that if not remedied could lead to significant consequences in the future. As such, a near-miss is also an opportunity to improve system structure and stability, and an opportunity to reduce risk exposure to potential catastrophe [94][95].

According to the National Firefighter Near Miss Recording Program, a near miss is defined as an unplanned event that did not result in injury, illness or damage, but likely would have had there not been a fortunate break in the chain of events. The International Association of Fire Chiefs (IAFC) founded the near miss program in 2005, through funding from the Department of Homeland Security (DHS) and Fireman’s Fund Insurance. The program established the following goals [100]:

- 1) To give firefighters and Emergency Medical Technicians (EMT’s) the opportunity to learn from each other through real life experiences;
- 2) To help formulate strategies to reduce the frequency of firefighter and EMT injuries and fatalities; and
- 3) To enhance the safety culture of the fire and emergency service

The system provides a volume of near miss experiences which are shared with firefighters and EMT’s around the country. The system received its 5,000th report in 2013 and continues to record near miss events. The collected data is used to formulate

strategies to reduce firefighter injuries and fatalities. Information is disseminated by after action podcasts, electronic mail, and seminars [100].

4.2.2 Near Miss Data Recording

After interviewing senior managers of various construction projects, one study found that near miss reporting had not been given the same consideration and importance as accident investigation [101]. Similarly to other company specific programs, near miss reporting strategies also vary from company to company. The Bechtel Corporation uses the following steps for identifying and recording a near miss [98]:

- 1) Incidents occurs
- 2) Employee reports the event
- 3) Superintendent records the event
- 4) Management discusses the event at the next management meeting
- 5) Safety department publishes briefing report
- 6) Safety department makes recommendations on how to avoid such an event
- 7) Supervisors and safety team review the effectiveness of the corrective actions
- 8) If corrective actions are not effective, the supervisors and safety team reviews and establishes new procedures until the corrective actions are effective
- 9) If corrective actions are effective, a final report is issued to everyone on the project team

Conoco Phillips, an energy production corporation, uses a reporting system called the Industrial Hygiene Metrics and Reporting Procedure (IMPACT) to report and respond

to workplace accidents [102]. This incident reporting and action tracking tool is used to report and track all safety incidents. Serious incidents must be entered and reported in IMPACT as soon as possible after the incident but no later than two business days after the event. Exposure incidents, as defined by IMPACT must also be entered and reported in IMPACT within two business days after determination that the exposure incident occurred. The report is automatically distributed to managers and other safety personnel when the appropriate reporting fields have been completed. Specific fields of the IMPACT report are required to be completed to record the investigation and corrective actions. After a full investigation has taken place and actions to avoid recurrence have been identified, the information is entered in IMPACT [102].

Other companies implement automated technology to record and analyze near miss incidents [96]. Caterpillar, a heavy construction equipment manufacturer, uses an Autonomous Real-Time Tracking System of Near Miss Accidents (ARTTS-NMA) on construction sites [103]. This system employs ultrasonic for outdoor and indoor real-time location tracking, sensors for environment surveillance, Radio Frequency Identification (RFID) for access control as well as storage of safety information about workers, equipment and materials, and wireless sensor networks for data transmission. All system components are integrated into a RFID sensor network architecture that features a relatively low cost and fast implementation with a pure wireless network backbone [104].

4.2.3 Near Miss Reporting Methods

A research report about near miss reporting methods in the University of Texas healthcare system describes the development and implementation of the “close-call

reporting system”. This system allows the report to be submitted anonymously so that reporting personnel are not identified by their superiors. A multidisciplinary health care team adapted this approach to develop a close call categorization scheme based on human factor principles. This system, which is available in web-based and paper formats, allows reporters to submit close calls in a risk-free manner and enable the collection of information about the etiology of close calls. This information is used to identify areas of vulnerability and to develop interventions that can prevent problems from recurring. The development and implementation processes provide a comprehensive framework that can be used for future deployments of similar patient safety systems. The framework includes the following categories for consideration when developing a near miss reporting system:

- 1) Definition of a close call
- 2) Potential barriers encountered
- 3) Feedback mechanisms to reporters
- 4) Format and content of the system

The research team developed close call categories including blood transfusion, diagnostic test procedure, equipment and devices, falls, medication, other treatment, surgery, therapeutic procedures, and contributing factors [105].

Another method of reporting incidents in the healthcare industry, specifically when working with hydrogen, is The Hydrogen Incident Reporting Tool [106]. This tool is intended to facilitate the sharing of lessons learned, voluntarily, and other information gained in real experiences that occurred while working with hydrogen. The target audience for this tool is users of hydrogen technology. A web-based database was created

for users to allow access for the intended users at any location with internet access. The safety event record in the database is characterized such that it facilitates a means for users to search and access information about specific records. The following list shown in Table 4 displays the different search criteria [106]:

Table 4: Search criteria for recorded close call events [106]

Category	Description
Title	Uniquely characterizes the nature of the safety event in a shortened form
Severity	Identifies the event as an incident, near miss, or non-event utilizing the noted definitions (a non-event is defined as a situation, occurrence, or other outcome that is relevant to safety)
Description	Describes the incident and contains any applicable information such as discussion of causes, other reports, photographs, and sketches
Lessons Learned	Defines the lessons learned and specific suggestions for avoiding similar incidents in the future
Causes	Characterizes the primary cause(s) of the event (e.g. abnormal operations, laboratory experiment, routine maintenance, and equipment failure)
Setting	Where the event occurred (e.g. laboratory, hydrogen production facility or hydrogen delivery vehicle)
Equipment	What types of equipment were involved (e.g. flexible hosing, piping and fitting, storage vessel, or cylinder)
Characteristics	Defines the hydrogen involved as high pressure or low temperature
Discovery	Defines when the event was discovered (e.g. during operation, maintenance, or inspection)
Hydrogen Release	Notes whether hydrogen was released during the event
Ignition	Notes the source of ignition, if applicable
Damages	Characterizes the nature of the damage or injuries
Factors	Characterizes factors contributing to the event, ranging from human error to equipment failures

One of the most effective methods reviewed for data collection of near misses is an online database format. Many industries have an online database that is searchable using industry specific criteria. These databases are comprised of information that is submitted voluntarily by the workers that are involved in the incident or by other

witnesses of the event. The information can be submitted to the online database anonymously or with the person submitting being identified. Dissemination of the analyzed information has been shown to dramatically increase both the number and quality of reports [47].

4.2.4 Near Miss Reporting Methods in Other Industries

Near miss reporting has been found to be an effective management tool in other industries. Statistically significant decreases of lost time injury rates in offshore drilling suggesting an increase in near miss reporting may lead to a 60 percent reduction in lost time injuries. In onshore oil and gas programs, a near miss reporting rate of 0.5 near miss reports, per person, per year was correlated with a 75 percent reduction in lost time injuries [95].

Annually, around 44,000 patients die as a result of medical errors [107]. Perhaps this is the reason that healthcare professionals, particularly doctors, are reluctant to report adverse events to their superiors [108]. For a period of 19 months beginning in 2001, researchers recorded errors related to transfusion medicine. The researchers recorded 819 near miss events. They concluded that of the 819 near misses reported, the median number of events per month was 51 and that overall, 61 of the events were potentially life threatening. The three most concerning events that were recorded were: 1) samples collected from the wrong patient, 2) mislabeled samples, and 3) requests for blood for the wrong patient [109]. Barriers and reporting incidents of nursing homes were also investigated [110].

In the chemical process industry, the analysis of near-miss management has been studied and detailed [106]. Seven stages are presented that outline the reporting of a near miss in the chemical process industry: 1) Identification, 2) disclosure, 3) distribution, 4)

direct and root-cause analysis, 5) solution determination, 6) dissemination, and 7) resolution. The study describes how employees may be reluctant to report near misses due to potential recriminations that could result. These potential recriminations are:

- Peer Pressure: Employees may feel pressure from colleagues not to report
- Investigation Style: Length investigations that require employee participation may discourage future reporting
- Direct Disciplinary Action: Concern of receiving a verbal warning, addition of incident to employee record, up to and including job dismissal discourage reporting
- Unintended Disciplinary Action: Upon incident investigation, additional job tasks or wearing cumbersome PPE may be perceived as punishment for reporting [94]
- Lack of an incentive to report: The significance of reporting events has not been communicated to workers [106]

When a near miss event occurs in a nuclear reactor, or if Nuclear Regulatory Commission (NRC) inspectors discover damaged or deteriorating equipment, the NRC reviews the risk to the reactor. According the Union of Concerned Scientists (UCS) report, over 200 such reviews were conducted by the NRC in 2010 [111]. Most incidents discovered at nuclear plants are low risk, but when an event or condition increases the risk of reactor core damage by a factor of 10, the NRC likely dispatches a Special Inspection Team (SIT). When the risk increases by a factor of 100 or more, an Augmented Inspection Team (AIT) may be sent to investigate, and an Incident Inspection Team (IIT) is sent if the risk increases by a factor of 1,000 or more. While no IIT's were dispatched in 2010, there were 14 instances, known as "near-misses," when the NRC had to dispatch inspection teams, including one AIT [111]. In Ireland, the energy industry is making an effort to improve their near miss data recording practices. The initiative has

been underway since 2011 and the industry is seeing exponential increases in reporting [112].

A study was conducted over a period of seven years between 1999 and 2006 at a mid-sized electrical manufacturing plant in an effort to prevent workplace injuries. A database of near misses, minor injuries, and OSHA recordable injuries was created. During the study's duration, 1,690 events were reported including 261 near misses, 1,205 minor injuries and 205 OSHA recordable injuries [113].

Companies conducting transportation services have also benefitted from reporting and analyzing near misses [114]. Safety in the aviation industry in the United Kingdom is continuously monitored by the Civil Aviation Authority (CAA). This organization has implemented a number of mechanisms in place for reporting and assessing potential safety incidents. The CAA operates a Mandatory Occurrence Reporting Scheme (MORS) in accordance with the European Union (EU) Directive. The program is intended to record occurrences which endangered or which, if not corrected, would have endangered an aircraft, its occupants, or any other person. The objective of the scheme is to contribute to the improvement of air safety by ensuring that relevant information on safety is reported, collected, stored, protected and disseminated. The goal of occurrence reporting is to prevent accidents and incidents, and not necessarily to attribute blame or liability. The scheme applies to all registered or operated aircraft in the United Kingdom's airspace [115].

Aircraft Proximity Hazard (Airprox) is an aviation industry term for what is commonly referred to as a near miss. The United Kingdom's Airprox Board is an independent organization sponsored jointly by the CAA and the Ministry of Defense to deal with all Airprox events reported within the United Kingdom's airspace. The primary objective of Airprox is to enhance flight safety with regards to lessons learned and applied from near miss occurrences. An Airprox is a situation in which, in the opinion of a pilot or a controller, the distance between aircraft as well as their relative positions and

speed have been such that the safety of the aircraft involved was or may have been compromised. Safety recommendations were aimed at reducing the risk of recurrence of a particular Airprox. These reports can only be made by pilots or air traffic controllers and cannot be submitted by passengers or members of the public who are on the ground.

While the previously discussed industries have implemented various elements of near miss management programs, the construction industry has been slower to adopt near miss reporting [47]. Benefits of identifying, reporting, and analyzing near miss events include an opportunity to learn in order to prevent these events from occurring in the future. However, these recording methods also experience limitations. These limitations can be that there is no incentive to report a near miss occurrence, or that workers may be fearful that there will be negative repercussions from reporting a near miss. The worker may feel they may be retaliated against for reporting the incident.

In summary, the BLS keeps record of workplace accidents, but does not track near misses. Several industries including construction, firefighting, healthcare, airline, and chemical processing have specific and unique definitions of the term near miss, but some similarities exist in the overall theme. These industries have developed and are currently implementing near miss identification and reporting methods that are intended to be used as an education tool for workers. Although near misses can greatly improve safety performance measurement and potentially performance, no single measure of safety performance is optimal, but rather the entire safety picture generated by using all prescribed safety measures [45].

4.3 Objective and Scope

The primary objective of this research is to identify best practices associated with near miss reporting programs including effective methods for identifying, collecting, and

assessing near miss information. The research scope is confined to the construction industry; however experiences gained through the use of near miss reporting in other work settings in other industries will also be exemplified. Only non-injury, non-fatal events, and portions of safety programs addressing these near miss events are examined. The created near miss reporting program is specifically designed for implementation within construction companies.

4.4 Methodology

In order to accomplish the stated objective, the research utilized a methodology including a detailed literature review, interview of construction site personnel, creation of near miss reporting guidelines, and validation through periodic monitoring of near miss reporting programs on active construction sites. The flowchart for this methodology can be viewed in Figure 6. Specific terminology and details included in the flowchart will be referenced throughout this section.

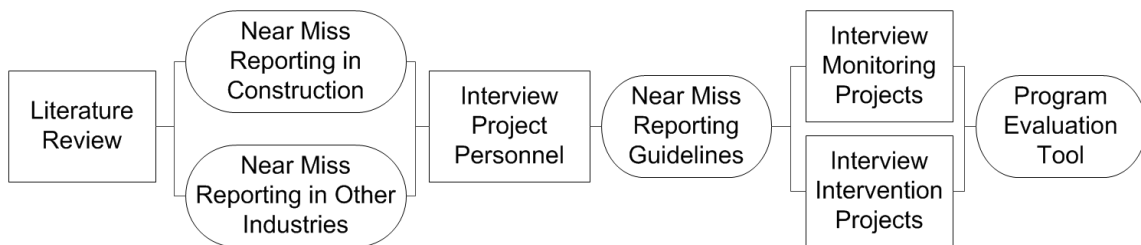

Figure 6: Research methodology flowchart for near miss reporting

4.4.1 Literature Review

Safety performance of construction workers is largely measured by lagging indicators including injuries, illnesses, and fatalities [13]. Although previous research has focused on leading indicators for construction safety, minimum emphasis has been placed

on reporting and analyzing near misses. Literature on near miss data collection and reporting methods were reviewed including construction and non-construction applications. Industries and organizations such as firefighting, airlines, manufacturing, chemical processing, energy production, the U.S. military, and the medical field have found value in reporting near miss events. Leading safety companies within the construction industry are also reporting and analyzing near miss data. These industries and individual companies provided near miss reporting program material, definitions of near misses, and process of information flow for reporting and analyzing near miss information.

4.4.2 Initial Construction Site Personnel Interviews

Participants of this research were safety directors assigned to active construction projects in which a near miss reporting program was implemented. An interview sample size determination equation [115][119] was used to determine the number of participants. The following parameters were used to determine a sample size of construction companies required: estimated variance in population is 0.5, desired precision is 0.05, confidence level is 95%, the number of people in the population is 729,345 [1]. With an estimated response rate of 100%, a total of 75 participants were needed. The limiting variable of the site personnel interviewed was restricted by the availability of construction sites presented by members of the research team. A total of 47 construction sites were initially interviewed.

Findings of the literature review were used to identify evaluation criteria required for near miss reporting programs. Various interview questions were created from the

review for construction safety managers, field supervisors (foremen), and laborers on active construction sites. A copy of the interview questions used for all three categories of site personnel can be found in Appendix A of this report. The created interview questions inquired about information regarding the following:

- 1) Company Information: Safety record (OSHA TRIR), annual revenue, number of employees, and services provided
- 2) Project Information: Total cost, percent complete, safety record, cumulative work hours, first aid incidents, number of safety personnel and first line supervisors
- 3) Near Miss Reporting Program: Initiating party, near miss definition, flow of near miss information, investigation strategy, number of reported near misses, overall perception of the program, description of all aspects of the program

Participating interview personnel were from construction companies that had previously implemented a near miss reporting program. A total of 47 interviews (21 phone interviews and 26 site visits) of different construction sites were conducted to compile data about existing near miss reporting programs. For each interview, one safety manager, two crew supervisors (mostly foremen), and two workers (craft workers and laborers included) were questioned. The country and region of the interview projects are listed in Table 5. The interview project locations and number were limited to the available active construction sites with near miss reporting programs who desired to participate in the study.

Table 5: Location of interview projects

U.S.		International	
<i>Region</i>	<i>Number</i>	<i>Country</i>	<i>Number</i>
Northeast	2	Canada	7
Northwest	6	Singapore	2
Southwest	12	Norway	1
Southeast	17		

Figure 7 shows the various locations of individual construction projects that were interviewed including unique symbols to designate the cost, the number of cumulative work hours (duration), and the number of workers. The symbols in Figure 7 are sized based on a ratio for the minimum and maximum value for each category. For example, the project with the largest amount of workers has the largest hard hat symbol.

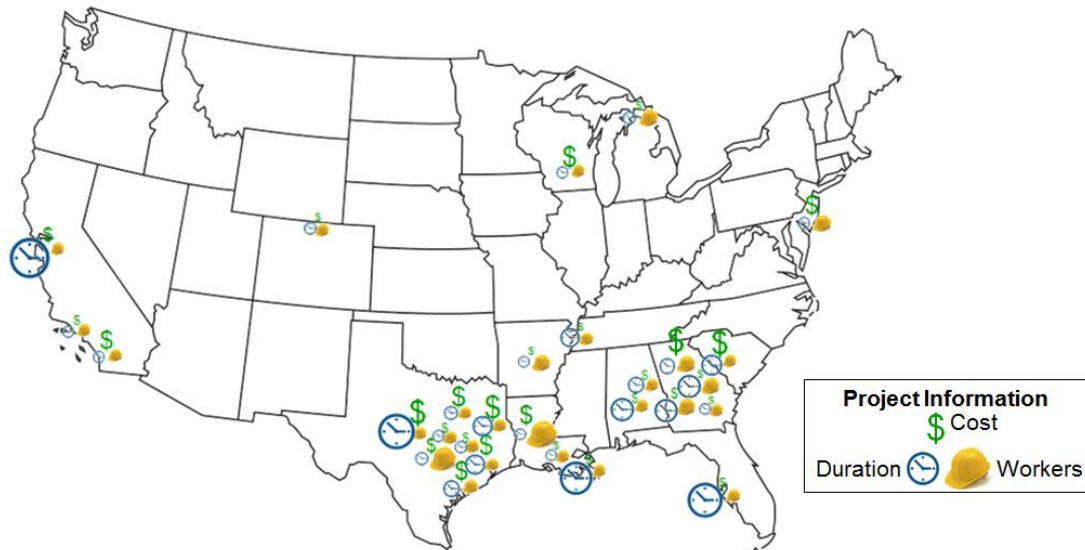

Figure 7: Initial interview project location, cost, duration, and number of workers

In addition to being located in various parts of the world, construction sites that were interviewed also had a wide range of costs, construction type, number of personnel,

number of safety personnel, cumulative work hours, and OSHA TRIR's. Table 6 gives the range values for some of the metrics evaluated.

Table 6: Interview project metrics

Project Metric	Median	Range
Cost	\$1.5 billion	\$5 million to \$10 billion
Cumulative Work Hours	1.6 million	10,800 to 12 million
Number of Workers	408	26 to 2,600
Number of Safety Personnel	6	1 to 60
OSHA TRIR	0.82	0 to 4.30

Cronbach's alpha was used as the reliability measurement method for information obtained from the interviews [120]. Participants of the survey were given asked to respond to the same question two different times during the interview. Participants were asked on two different occasions to give the number of near misses he or she had reported during a certain time period. Because a majority of the respondents provided the same number for both questions, the Cronbach's alpha from this initial survey was 0.91. Cronbach's alpha values higher than 0.7 are deemed to be reliable interview results from the respondents questioned.

4.4.3 Near Miss Reporting Guidelines

The quantitative and qualitative data compiled from the initial construction site personnel interviews were analyzed to formulate preliminary conclusions regarding ways of implementing and monitoring effective near miss programs within construction companies. A preliminary set of guidelines for an effective near miss reporting program was created based on the review and interview analysis results. The guidelines were

divided into seven separate categories: 1) Define, 2) roll out, 3) collect, 4) analyze, 5) corrective actions, 6) share, and 7) share.

4.4.4 Long Term Construction Site Personnel Interviews

The created near miss reporting guidelines were deployed into nine different construction sites of nine different construction companies for further evaluation longitudinal study. The research team completed monthly interviews with identified safety managers for each construction site for a four month duration. The safety managers were asked for the following information:

- Number of near misses reported
- OSHA total recordable events reported
- Cumulative work hours
- Project OSHA TRIR
- Number of stop work authority events
- Opinion concerning the effectiveness and value of the program
- Experienced benefits and limitations
- Changes made to the near miss reporting program
- Effectiveness of each change implemented

Of the construction sites selected for interview of safety managers, five were selected as “intervention.” This term is used to describe the sites because each general contractor on the five construction sites fully implemented the created near miss reporting

program guidelines. The other four construction sites selected for interview projects were categorized as “monitoring” projects because each general contractor had previously implemented a near miss reporting program. For the monitoring projects, the general contractor adopted portions of the newly created guidelines, but did not implement every component of the created near miss reporting guidelines. Results of the monthly safety manager reviews allowed for further modifications of the created near miss reporting program. The interviews also provided a test and validation for the implemented near miss reporting program.

4.5 Results

Results of the construction site personnel interviews, literature review, and existing near miss reporting programs were used to create best practice guidelines for a near miss reporting program, a process framework for information flow of near miss reporting, and several research deliverables that supplement the near miss reporting guidelines including a database template and program evaluation tool.

4.5.1 Initial Construction Site Personnel Interviews

Several statistical analyzes were performed on both the quantitative and qualitative data collected during the interviews of safety managers, supervisors (mostly foremen), and craft workers. A stepwise regression was completed based on the quantitative results of the construction site personnel interviews. The regression performed at a 95% confidence interval resulted in a p-value less than 0.0001, an adjusted r-squared value of 0.89, and a standard error the estimate was 17.4. The dependent

variable for the regression was near misses reported per cumulative work hour to normalize the various sizes and scopes of construction sites interviewed. Of the variables evaluated, the following collectively statistically explained 26% of the correlation with near misses reported per cumulative work hour: 1) Reported first aid incidents, 2) near misses investigated, and 3) number of craft workers on the construction site. Table 7 shows the evaluated coefficients and their corresponding weights based on the results of the construction site personnel interviews. The results indicate that of the interview data collected, the OSHA TRIR was the most highly correlated with the number of near misses reported. (e.g. the lower the OSHA TRIR, the higher the number of reported near misses).

Table 7: Dependent variables of the near miss reporting interview data

Variable	Weight
OSHA TRIR	42.21%
Near misses investigated	11.42%
Number of safety personnel	9.87%
Number of first aid incidents	9.65%
Number of supervisors	8.38%
Number of craft workers	5.23%
Safety manager years of experience	4.89%
Safety manager time on the project	4.25%
Percent complete	4.01%
Number of field workers	0.01%
Cumulative work hours	Less than 0.01%
Project cost	Less than 0.01%
Annual revenue	Less than 0.01%
Number of employees	Less than 0.01%

4.5.2 Near Miss Reporting Program Guidelines

A set of near miss reporting guidelines were created based on identified best practices from the literature review and initial construction personnel interview effort. The near miss reporting program guidelines are separated into individual steps of the

following near miss reporting cycle. Each of the seven steps contains recommended best practices for a near miss reporting program within a construction company. The guidelines are categorized into the following: 1) Define, 2) rollout, 3) collect, 4) analyze, 5) corrective actions, 6) share, 7) encourage. The near miss reporting cycle is displayed in Figure 8.

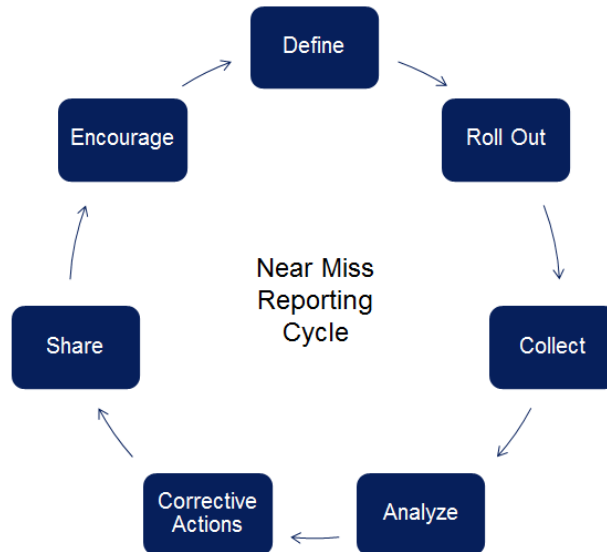

Figure 8: Near miss reporting program cycle

4.5.2.1 Define

A set of suggestions were created regarding the definition of a near miss reporting program including general program information. The suggestions listed are:

- 1) Contractor should develop a company specific near miss reporting program that is suited for their type of work
- 2) The near miss reporting program can be tailored to meet specific needs of each individual project

- 3) Owners should require a near miss reporting program as a prequalification requirement for contractors
- 4) If the owner requires a different near miss reporting program, the contractor may be required to implement additional regulations and practices to satisfy the owner
- 5) Program should remain flexible to accommodate varying site conditions and safety cultures
- 6) Safety managers should create a company specific definition of what qualifies as a near miss.
- 7) General near miss definition: “An unplanned event or unsafe condition that has the potential for injury/illness to people, or damage to property, or the environment.

Near miss definition examples:

- Hazardous conditions where no bodily or property damage occurred, but a situation that requires investigation to prevent future occurrences
 - An opportunity to improve safety practice based on a condition, or an incident with potential for more serious consequence
 - A specific event, or sequence of events, or extended conditions that could have produced unwanted or unintended impacts on the safety or health of people, property, or the environment
- 8) A near miss definition should accomplish the following:
 - Differentiate near misses from worker injuries, illnesses, or fatalities
 - Describe near misses as an event, set of conditions, unsafe behavior, or combinations of these

- 9) Possible alternate terms for near misses: Opportunity for Improvement (OFI), near hit, near accident, near loss, and good catch

4.5.2.2 Roll Out

Based on the literature review and initial construction site personnel interview data, recommendations were created for rolling out (or implementing) a near miss reporting program within a construction company. The recommendations are the following:

- 1) Introduce new employees to general aspects of near miss reporting through new employee orientation
- 2) Educate employees on specific aspects of the near miss reporting program through site specific safety orientation
- 3) Subcontractors should understand and utilize the general contractor's near miss reporting program
- 4) Workers should be trained to identify near misses (most important: high frequency and high severity incidents) through hazard recognition
- 5) Safety managers can train workers on near miss recognition and reporting as the project's schedule progresses (for example, train workers to identify near misses associated with concrete before construction on the foundation begins)
- 6) Inform workers of barriers to near miss reporting (e.g. fear of retaliation) and educate workers on how this program bridges these gaps

- 7) Administrative training is also necessary so that safety managers and company managers can access, understand, and analyze the near miss reporting information
- 8) The near miss reporting program should be integrated into the existing company's safety program

4.5.2.3 Collect

Construction site personnel educated on identifying a near miss should be provided an effective system to report near misses. The following recommendations provide guidance on how to collect near miss data:

- 1) Anyone on the project can report a near miss (workers, supervisors, safety managers, or any other site personnel)
- 2) Anyone can report near misses for personnel from other crews or other companies
- 3) Worker and supervisor checklist form is available at several locations throughout the site (see Appendix A.4)
- 4) Information on checklist includes: Time of event, reporter, reporter's supervisor, incident type, severity, type of event, crew, frequency of previous events, incident description, safety category, and photos (by authorized owner or contractor representative)
- 5) The reporting process should include these steps in order: 1) Identification, 2) reporting, 3) distribution, 4) investigation, 5) solution, and 6) dissemination.
- 6) The information flow of near misses is shown in Figure 9. A description of each step is discussed in Table 8.

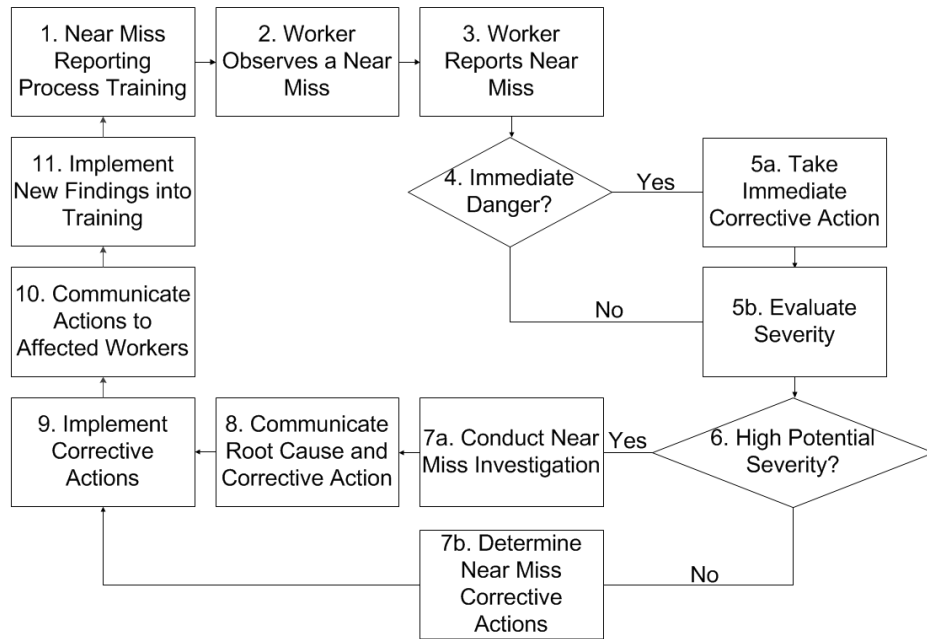

Figure 9: Near miss process information flowchart

Table 8: Steps and descriptions of the near miss process information flowchart

Step	Title and Description
1.	All construction site personnel are trained on all aspects of the near miss reporting program
2.	A worker trained in identifying near misses
3.	After observing, a worker reports the near miss on the reporting form and/or informs his/her immediate supervisor
4.	The worker and safety personnel decide if no action is taken to fix the situation, will a continued immediate danger exist?
5a.	If an immediate danger exists, the safety personnel and worker will first take immediate action to eliminate the danger
5b.	If an immediate danger does not exist or has been corrected, the safety personnel determines the severity (weighted score) of the reported near miss
6.	The severity of the reported near miss is determined from a previously established weighted scale
7a.	Safety personnel, supervisors, and the reporting worker review the report and visit the location of the reported near miss
7b.	The investigation team identifies hazards associated with the reported near miss and develop a corrective action plan
8.	Create a report detailing the findings of the near miss investigation and corrective action plan
9.	Safety personnel using the investigation findings and corrective action plan will correct the current conditions
10.	Findings of the investigation and corrective actions taken are reported to all site personnel at scheduled meetings
11.	Findings are integrated into existing safety training for workers

- 7) Standards can be established depending on project variables (number of craft workers, project size, number of supervisors, and many others) for the number and quality of near miss reports an individual submits (e.g. each worker must submit at least 2 near miss reports per week)
- 8) Supervisors should submit near miss reports on intrinsically safe mobile computer devices (e.g. an iPad or iPhone) using the near miss report form
- 9) Near miss worker reports should be entered into the near miss database by the end of the workday
- 10) Read-only database should be accessible to all employees

- 11) Supervisors should take and upload photos (when authorized) of the near miss incident into the database

A sample database template was created for immediate implementation or integration into an existing company safety reporting database. The database is capable of the following functions: 1) User-interface reporting form, 2) view table of near misses reported, and 3) reports based on specific criteria to near misses. The user must input the following information: 1) Date of event, 2) time of event, 3) severity (contains a pull-down menu), 4) project name, 5) company name, 6) crew members involved, 7) employees involved, 8) event description, 9) investigative team, 10) immediate cause, 11) contributing cause, 12) corrective action, 13) resolution description, 14) identification, and 15) category. The identification and category entries were derived from the Eindhoven classification system [106][121]. Definitions for each category of error including skill based, rule based, or knowledge based [122] are given in Table 9.

Table 9: Eindhoven classification system [106][121]

Identification	Category	Definition
Skill Based	Slips	Failure in highly developed motor skills such as using a hammer, using powered and non- powered tools.
	Tripping	Failure in whole body movements such as climbing a ladder, tripping on even ground, swinging arm out and hitting something, or kicking something.
Rule Based	Qualifications	The wrong combination of a person’s education and experience versus the task at hand. Asking someone to do something in which they have limited experience or no knowledge.
	Coordination	A lack of coordination between two construction groups such as walking into a barricaded area. Groups not coordinating with each other.
	Verification	The incomplete assessment of something on the worksite such as using equipment which hasn’t been inspected.
	Identification	Failures that result from faulty task planning such as hazards not identified on the Jobsite Hazard Analysis (JHA).
	Monitoring	Monitoring a situation inappropriately such as not realizing a hazardous situation.
	Compliance	Procedure which are not followed, off task, or taking a shortcut.
Knowledge Based	Knowledge	Inability of a person to apply their existing knowledge to a new situation such as a person not knowing a new rule.

A unique near miss identification number is assigned to each near miss reported. Every field should be eventually completed throughout the cycle of one near miss reported. Each near miss requires a new form. The table section displays each near miss reported and can be arranged by severity, company, or any other input metric. The database provides for tracking of an individual near miss by allowing for review input and resolution description of the near miss. Figure 10 displays the reporting form for this database template. A sample report and user instructions are shown in Appendix A.5 of this report.

Construction Industry Institute® IR 301-1		Near Miss Reporting Form	
Date	08-Nov-13	Near Miss ID	3: Critical Severity
Time	12:15:00 PM	Severity	2: Moderate Severity
Project	ABC Towers		1: Low Severity
Company	Construction, Inc.	Near Miss: An unplanned event or unsafe condition that has the potential for injury/illness to people, or damage to property, or the environment.	
Crew Involved	Electrical Installation Crew	Investigative Team	Bob Ross (Safety Manager), Joseph Simpson (Foremen), and Gary Williams
Employees Involved	John Smith, Gary Williams, Joseph Simpson	Immediate Cause	Employee mistakenly installed the ground rod into the incorrect location.
Equipment Involved	N/A	Contributing Cause	Employee was not notified of the existing 4" PVC conduit containing energized wires
Event Description	A contractor was installing electrical grounds. The employee drove a ground rod through a 4" PVC conduit containing energized wires (2400 V). All markings were done in pencil on wood concrete formwork.	Corrective Action	1) Conducted an immediate safety shut-down 2) Contractor, owner, contractors, and
		Resolution Description	1) Construction managers will better communicate specific locations of hazards to site supervision.
1st Reviewer	Mark Collard	2nd Reviewer	Sarah Talley
1st Review Date	09-Nov-13	2nd Review Date	10-Nov-13
		Resolution Reviewer	Scott Spalding
		Resolution Review Date	12-Nov-13
		Date Corrective Action Finalized	14-Nov-13

Figure 10: Near miss reporting form for the database template

4.5.2.4 Analyze

In an effective near miss reporting program, safety managers, and construction supervisors will receive many near miss reports from site personnel. The following suggestions advise near miss reporting program facilitators on how to effectively analyze near miss reporting information.

- 1) All reported near misses are investigated by an investigation team of a safety managers, the observer, the observer's supervisor, and any other personnel involved with the reported near miss
- 2) Near misses should be investigated within the week that the event occurs

- 3) After the investigation, the investigative team can assign a severity level to the event and update the report in the online database (e.g. category of 1, 2, or 3 where 3 is the most severe)
- 4) The near miss reporting database should be user friendly so that safety managers can easily enter and analyze near miss reports
- 5) An online company-wide safety database should be established for recording and trending all reported near miss events (should be integrated into an existing company safety database)
- 6) Company management personnel should have access to review near miss reports and analysis

4.5.2.5 Corrective Actions

The following items provide suggestions to construction companies on how to derive and implement corrective actions based on submitted near miss reports. Based on the findings of the investigation, the team can determine corrective actions.

- 1) The investigation team should identify and record root causes, and possible solutions to the near miss incident [56][123]
- 2) Findings of the investigation should be included in the near miss report in the database and shared company-wide during safety meetings

4.5.2.6 Share

After a near miss has been reported, investigated, and resolved; lessons learned information should be integrated into construction worker safety training. The following are suggestions on how to effectively disseminate gained knowledge:

- 1) Management personnel from the contractor and owner should hold a monthly meeting to discuss general information about the near miss reporting program
- 2) Near miss reports from one project should be accessible to all safety managers in the company to share with other project personnel
- 3) Safety managers should use results of near miss reports to improve safety training and education
- 4) Safety managers should discuss weekly high frequency or high severity near miss reports received in the previous week during project specific safety meetings
- 5) Safety managers should review the near miss reporting program during weekly safety meetings including: Previous reported near misses, changes to the near miss reporting program, weekly number of near misses, charts and graphs from analysis, and reminders to workers of the reporting process (self-promoting the program)
- 6) Incorporate details or lessons learned from near miss reporting into safety toolbox talks

4.5.2.7 Encourage

As is true for many safety program components, strategies must be established to encourage employees to report near misses. The following are recommendations on how to encourage employees to report near misses:

- 1) Workers should receive no punishment for reporting near misses unless it directly violates a current safety policy (advertise as fact-finding and not fault-finding)
- 2) Near miss reports are posted on the project's bulletin board and other signs throughout the project
- 3) Lessons learned from near miss reporting can be printed in the company's newsletter
- 4) Workers that speak languages other than English should be provided aid (near miss reporting information in other languages or through a bi-lingual translator)
- 5) A message should be broadcast over the workers' radio to remind them to report near misses
- 6) Incentives: Reward workers for quality and quantity of submitted near miss reports
- 7) The safety manager should communicate the significance of the near miss reporting program
- 8) Company management should invest and advertise the near miss reporting program
- 9) Safety managers should communicate and maintain positive relationships with workers

4.5.3 Near Miss Reporting Evaluation Tool

A tool was created to evaluate an existing near miss reporting program within a construction company. The evaluation tool allows users additional interaction with the near miss reporting guidelines by comparing a specific near miss reporting program within a construction company to the presented guidelines. Safety managers and other management personnel within a construction company are given several questions pertaining to their specific near miss reporting program. The goal is to provoke thought about modifications or additions that can be made to existing near miss reporting programs while a user is completing the exercise. User responses are also used to provide an overall metric and category specific metrics. Suggested practices based on the near miss reporting guidelines will be provided for the user. The tool informs users of “needs” areas in which suggested modifications to the program are provided. A sample interface page of this evaluation tool for the “General Program Information” section can be viewed in Figure 11.

1. Project Information	2. General Program Information	3. Database Requirements	4. Employee Training	5. Encourage Reporting	6. Investigation
------------------------	--------------------------------	--------------------------	----------------------	------------------------	------------------

Project: _____

SECTION 2: GENERAL PROGRAM INFORMATION

1. How well has the near miss reporting program been tailored to the company's specific type of work?
 Not at all Minimally Somewhat Adequately Very well

2. How well is the near miss reporting program modified to meet specific needs of each individual project?
 Not at all Minimally Somewhat Adequately Very well

3. How well is the near miss reporting program aligned with specific needs and regulations of the owner?
 Not at all Minimally Somewhat Adequately Very well

4. Do the contractor and owner meet periodically to discuss general information about the near miss reporting program?
 Yes No

5. How flexible is the system to accommodate varying site conditions and safety cultures?
 None Minimal Somewhat Adequately Very



Figure 11: Sample user interface of the near miss reporting evaluation tool

Users of the near miss reporting program evaluation tool will be asked to rate their input towards a total of 63 statements and short answer responses. The content for each statement was derived from the near miss reporting program guidelines. Each question is weighted evenly, but this can be modified by the user to further customize the near miss reporting program. The final interaction allows the user to access recommendations from the near miss reporting guidelines based on their individual program score. This evaluation tool can be used throughout the lifecycle of a project to monitor the progress of the near miss reporting program. For a list of all statements posed by the near miss reporting evaluation tool, see section A.6 in the Appendix of this report. Figure 12 shows an interface provided to the user after all responses are recorded within each section of the tool have been answered.

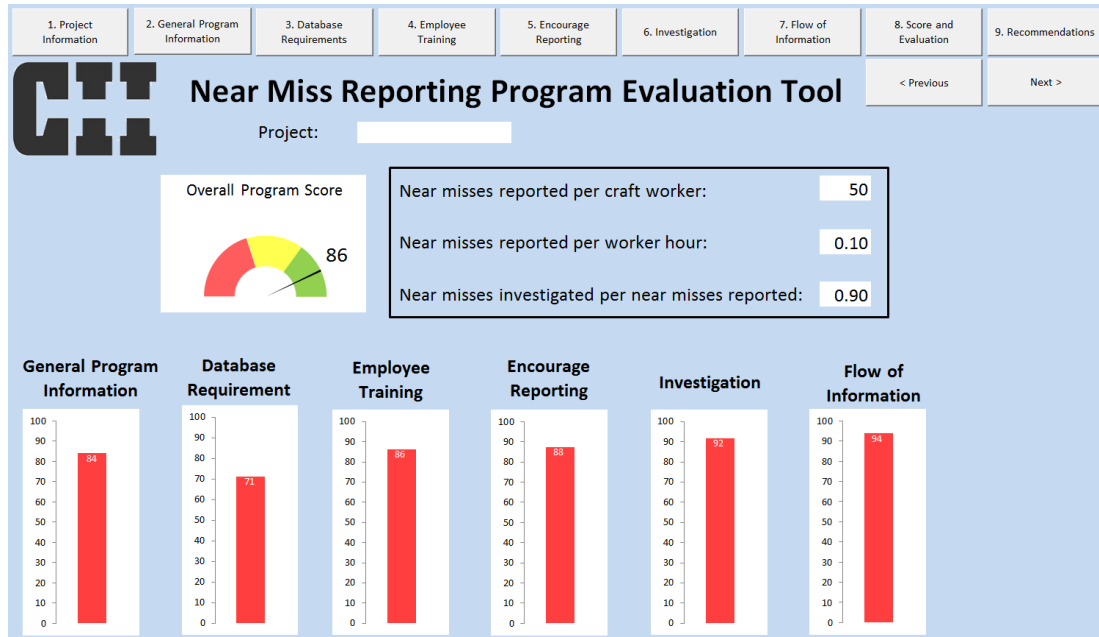

Figure 12: Scoring interface for the near miss reporting evaluation tool

4.6 Conclusions

The construction industry desires to eventually obtain an accident free jobsite including a zero fatality rate for each construction project. Current industry standards require the measurement and recording of lagging indicators such as illnesses, injuries, and fatalities which only provide safety performance measurement after an incident occurs. Identifying, reporting, and analyzing safety leading indicators including near misses can enhance employee abilities to identify hazards, improve safety training, and validate performance metrics. This research shows that near miss situations can be recorded and analyzed through an effective near miss reporting program.

A review of existing near miss reporting programs within construction companies and other industries was completed. Further investigation was conducted on specific components of near miss reporting programs including the definition of a near miss,

reporting strategy, and flow of information. Several construction personnel interviews on active construction sites with a near miss reporting program were conducted. A second phase of interviews periodically surveyed active construction projects that implemented the suggested near miss reporting guidelines. Interview results were used to create best practice guidelines for a near miss reporting program, an information process flowchart for near misses, and an evaluation tool for existing near miss reporting programs.

Future work includes automatically reporting and analyzing near miss data from an active construction site. The program evaluation tool could also record and archive entries to provide a longitudinal progression of success and failures of the near miss reporting program. A separate interface would trend the performance of the near miss reporting program over time. Currently, the tool does not archive or trend past performance metrics. New safety concepts and training can evolve from the analysis of near miss data collected from a construction project. Workers can be trained on existing hazards on the site from reported near misses before an accident occurs.

CHAPTER 5

EQUIPMENT OPERATOR VISIBILITY MEASUREMENT AND ANALYSIS FOR SAFE EQUIPMENT DESIGN

Contact collisions between ground workers and construction equipment are often attributed to limited equipment operator visibility. This chapter presents a method for measuring and analyzing equipment operator visibility by utilizing laser scanning. Several models of skid steer loader are evaluated to understand the impact of construction equipment design on operator visibility. By capturing areas invisible to an equipment operator, hazardous areas for ground workers can be identified and avoided.

5.1 Introduction

Most construction sites are characterized by a multitude of interactions between construction equipment, workers, and materials. This dynamic environment creates many visibility related issues for construction workers and equipment operators. Non-visible areas, called blind spots, are one of the leading causes of contact collisions between ground workers and construction equipment in the construction industry [61]. Blind spots impede the line-of-sight (LOS) of construction equipment operators creating non-visible areas for the operator outside of the equipment cab. Contact collisions can occur when workers, equipment, or materials enter these blind spots undetected by the equipment operator. The significance of this research is to implement a blind spot measurement technique to demonstrate how safety can be promoted through construction equipment design.

The International Organization for Standards (ISO) code 5006 and 14401-1 standards describe the experimental specifications for equipment blind spot measurements [124][125]. However, the specified method is labor intensive, requires special expertise, and is sensitive to environmental parameters such as illuminations and spatial constraints [57]. Consequently, the blind spots estimation can be subjective and error prone. This method has been used to measure the operator visibility of a variety of different pieces of construction equipment [126][127][128][129].

This research utilizes a commercially available laser scanner capable of producing a 3D spatial point cloud from both inside and outside the equipment cab. Specifically, this research used four different models of commercialized skid steer loaders as an example to demonstrate the applicability of blind spots measurement on the variety of equipment design. The goal of this study is to demonstrate that equipment design has impact on construction equipment operator visibility and blind spots.

The data recorded from the blind spot measurements was analyzed for percent visibility and visible areas versus non-visible areas of an equipment operator as specified in the ISO code standards. Measuring blind spot data for different models of skid steer loaders can reveal which model and design characteristics provide the optimal visibility and least amount of blind spots for an operator. By limiting the research scope to different model types of skid steer loaders, the best design characteristics for safety can be realized and recommended for that specific piece of construction equipment.

5.2 Background

Visibility related issues have an impact on the overall safety of the construction industry. One of the leading causes of contact collisions between construction equipment and workers are blind spots [57][61]. Blind spots are a product of poor visibility in which an equipment operator's line-of-sight is impeded by components of the construction equipment.

5.2.1 Construction Equipment Visibility-Related Issues with Safety

The close proximity of workers on the ground to construction equipment creates many visibility-related issues for operators. Blind spots restrict an operator's line-of-sight to objects outside of the construction equipment cab. Many accident investigations and research studies found that visibility-related issues created by blind spots caused operators to 1) run over workers and materials, 2) contact other equipment, and 3) rollover construction equipment [62].

The National Institute for Occupational Safety and Health (NIOSH) has compiled blind area diagrams for 43 pieces of construction equipment. These blind area diagrams were developed using manual methods and standards described in the ISO codes 5006 and 14401-1 standards. This information was produced to develop awareness about hazardous areas around construction equipment [144].

5.2.2 Skid Steer Loaders

As smaller and more mobile equipment emerge in the construction industry, the unique configuration of the skid steer loader allows it to complete a variety of

construction tasks efficiently. Its compact design and small rigid frame allows the skid steer loader to operate quickly and in small spaces. Skid steer loaders have become a very effective piece of equipment when assisting groups of workers on the ground. Because of its ability to operate in compact spaces, construction workers are often located in close proximity to the equipment which can create visual awareness issues for the equipment operator [199].

The Fatality Assessment and Control Evaluation (FACE) Program was created by NIOSH to concentrate on investigations of fatal occupational injuries. Between 1992 and 1997, the FACE program identified 37 fatalities involving construction workers and skid steer loaders [200]. Other research conducted on construction equipment operator visibility found that more than half of all visibility-related fatalities occurred when construction equipment is moving in the reverse direction [201]. The cases evaluated by the study found that approximately 93% of fatalities involving skid steer loaders occurred when the equipment was moving in the reverse direction. Previous studies have found the commonly known blind spots of construction equipment are to all sides of a piece of equipment [130]. The limited operator visibility, specifically to the rear of the skid steer loader, made this piece of construction equipment a perfect candidate for this research. Constraints of construction equipment available to the researcher also factored into the decision to measure visibility of skid steer loaders.

There have been many developments in operator safety for skid steer loaders. Each of the four skid steer loader models were equipped with the following safety features [202]:

- Control interlocks
- Rollover Protective Structures (ROPS)
- Falling Object Protective Structures (FOPS)
- Side screens

Most recent advancements in skid steer loader design have been to remove one hydraulic lift arm. This provides an entrance (similar to a car) on the side of the equipment. Providing air-conditioned cabins for equipment operators also allowed the removal of the metal mesh frames that protected workers from sticking out their arms.

5.3 Objective and Scope

The objective of this research chapter is to explore the impact of construction equipment design on the operator's visibility. This includes identifying critical parts of a skid steer loader cab that creates blind spots. Four commercially available skid steer loader models (see Figure 13) were evaluated with regards to the operator's visibility by using one laser scanner to simulate the vision of a human operator positioned in the equipment cab. Each evaluation created a rendering of the non-visible areas (blind spots) for the different construction equipment and models tested. Possible environmental impacts (e.g. sunlight and influence of temperature) were not considered for the blind spot measurement methods.



Figure 13: Selected skid steer loaders for the study

5.4 Research Methodology

The workflow for this research was divided into four sequential processes: 1) data collection, 2) data processing, 3) blind spot identification, and 4) allocation of design inefficiencies. This workflow measured blind spot data for construction equipment, transformed the raw data into operator visibility diagrams and quantifiable blind spot data, and displayed best design characteristics with regards to safety for skid steer loaders. Other pieces of construction equipment were evaluated and are included in the Appendix B section.

5.4.1 Spatial Point Clouds

Data collection for blind spot data used a blind spot measurement tool with a 3D laser scanner to evaluate different models of skid steer loaders. The measurement procedure is illustrated in Figure 14. A commercially-available 3D laser scanner recorded 3D spatial data from both a position inside each skid steer loader cabin. The scanner's mirror was positioned at the operator's eye-height as defined in the ISO-standards

[121][122]. Additional laser scans outside each skid steer loader were taken in four surrounding locations. Using these locations, the equipment's structural features creating blind spots were realized.



Figure 14: Laser scan measurement of the interior of an equipment cabin

Previous experiments found that the light source emitted by the laser scanners generally have no influence on the blind spot measurements [203]. Depending on the type of the 3D laser scanner, it registers and stores at a minimum approximately 1.5 million data points per scan in a point cloud data file. These data values were registered and then converted to a standard X, Y, and Z-coordinate system for blind spot analysis.

The experimental design of collecting geometry information of the construction equipment followed the requirements from existing operator visibility measurement standards. Both the ISO code 5006 (Earthmoving machinery-operator field of vision test

method and performance criteria) and ISO code 14401-1 (Earthmoving machinery field of vision of surveillance and rear view mirrors part 1: test methods) were used as standards for blind spot measurement during the experiments [124][125]. The ISO code 5006 provides a manual equipment blind spot measurement method that was developed through years of worldwide experience with construction equipment. This method uses two bright light bars spaced at an average human eye width inside the equipment cab. The light is projected onto a flat surface around the outside of the equipment cab to determine the visible areas to the equipment operator. Dark or shaded areas can be interpreted as blind spots for the equipment operator. The ISO code 5006 specifies a 12 meter radius extended from the operator's position for the blind spot measurement area [124]. The ISO code 5006 requires the skid steer bucket height to be 300 millimeters with a tolerance of 50 millimeters in both directions. This is also known as the "carry position" of the bucket.

Each laser scan measurement took approximately 30 minutes (several hours faster than the specified manual method). An observed problem in preliminary experiments was the challenge of maintaining the bucket height at the same height throughout the experiment. Since the hydraulic lift arms release pressure over time, two small wooden support plates underneath the bucket kept its position in place for the duration of the measurement. There were no other moving parts that could have influenced the point cloud measurement. An additional issue with laser scanners is its potential for limited field-of-view (FOV). Most laser scanners cannot measure the bottom parts of an equipment cabin, such as the cab floor or operator chair.

All experimental tasks were executed using specifications and guidelines from both ISO codes 5006 and 14404-1 [124][125]. The experimental procedure differed in some aspects from the suggested ISO code 5006 manual measurement method. The 3D laser scanner emits a light source from one central location rather than using two light sources prescribed in the ISO code 5006. This method better simulates the visibility of an equipment operator positioned at one central location within the skid steer loader cab. Previous research indicates that emitting a light source from one location better simulates stereo or singleness vision which is more characteristic of human vision than two emitting light sources [204]. Unlike the ISO code 5006 method, the 3D laser scanner also allows the user access to visibility data from any point inside the cabin. Although the manual measurement method was replaced with a blind spot measurement tool, the experimental strategy, measurement dimensions, and results remained in compliance with the rules established by the ISO codes.

5.4.2 Data Processing

The 3D point cloud blind spot data captured by the 3D laser scanner was processed through commercially available construction design software for analysis. All of the projected lasers scanning points were traced from the operator's head position to detect if and where they intersected a piece of the equipment cab or other obstruction before touching the ground surface. If the projected laser scanning point intersected any obstructions before connecting to the ground surface, that point was deemed a blind spot.

The volume outside of the equipment cab is divided into virtual cubes creating a 3D grid. Because the laser point cloud penetrates the virtual 3D grid, all of the point

cloud data passes through one of the virtual cubes. Based on the visible or non-visible status of the point cloud passing through any given cube, the entire cube converts to the same visibility status. The volume of each cube is projected as an area onto a two-dimensional (2D) grid for analysis. These 2D grids are representations of the blind spot volume obtained by the laser scanner point cloud data. An average data processing time to evaluate the point cloud data and develop one blind spot maps is approximately 20 minutes for an experienced person with a modern computer. The 2D grids created for each skid steer loader can be viewed in later section of this chapter.

5.4.3 Blind Spots Identification

The blind spots were identified based on the occupancy grid map achieved from the previous step. In addition, specific factors that were defined in ISO standards were computed to evaluate the design of the equipment cab. The terms and explanations of this section should be used to interpret the experimental results.

Blind Spot Area(s): The invisible area(s) to the operator are shown by hatch marks in the drawings.

Rectangular Box (RB): A rectangular box is drawn around the equipment. The lines of the box are located on the ground reference plane at a one meter distance from the outside rectangular boundary of the equipment.

Visibility Test Circle (VTC): A circle with a 12 meter radius located on the ground reference plane with its center vertically below the center point of the operator's eye height level.

Visibility Test Person (VTP): A test person with a 1.5 meter in height and 0.6 meters in (shoulder) width.

Visible Angles (Lengths) on the Circumference: The angles and lengths on the circumferences of the 12 meter radius circle that is visible to the operator.

Plan, Side, and Front Views: The blind spot diagrams are displayed from different perspectives. The drawings provided in the results section are not to scale.

Figures 15 and 16 demonstrate how to interpret the figures in the results section of this paper. The specifications listed on Figure 16 for the side view are the same for the front view figure.

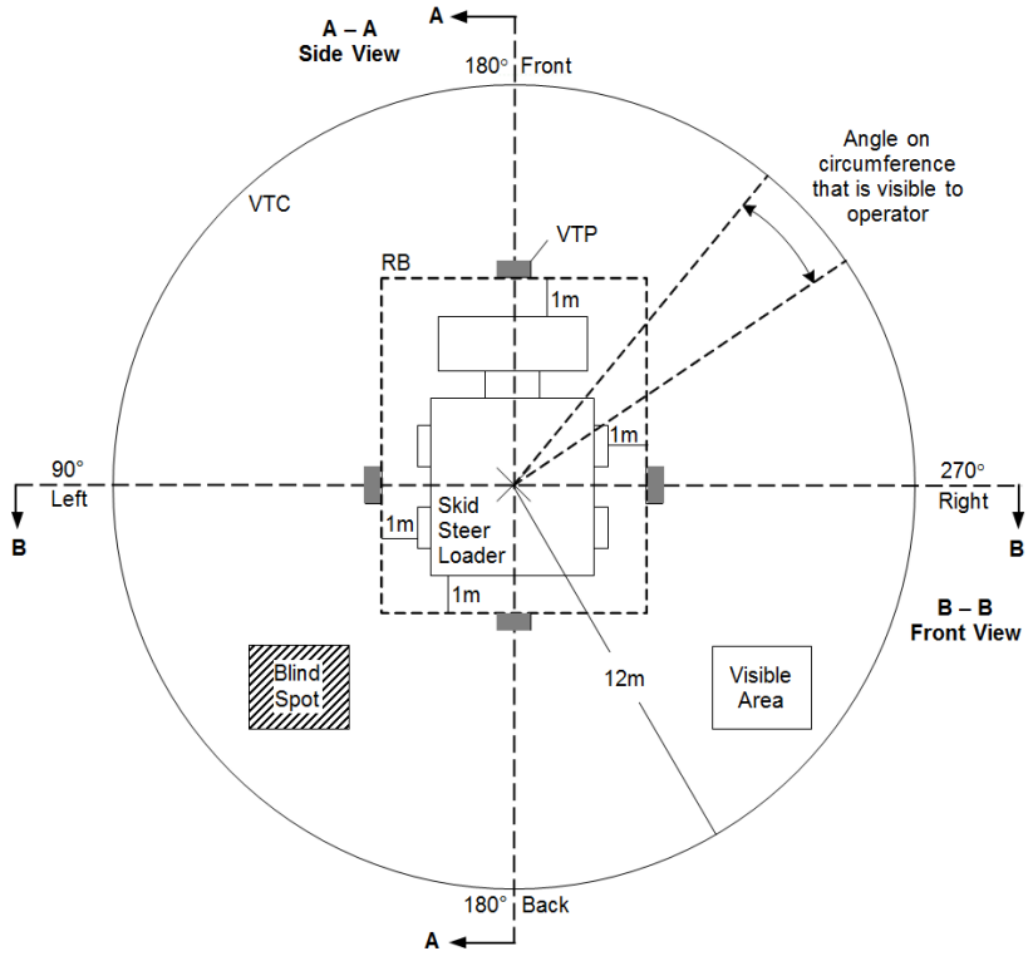

Figure 15: Reading the plan view diagram

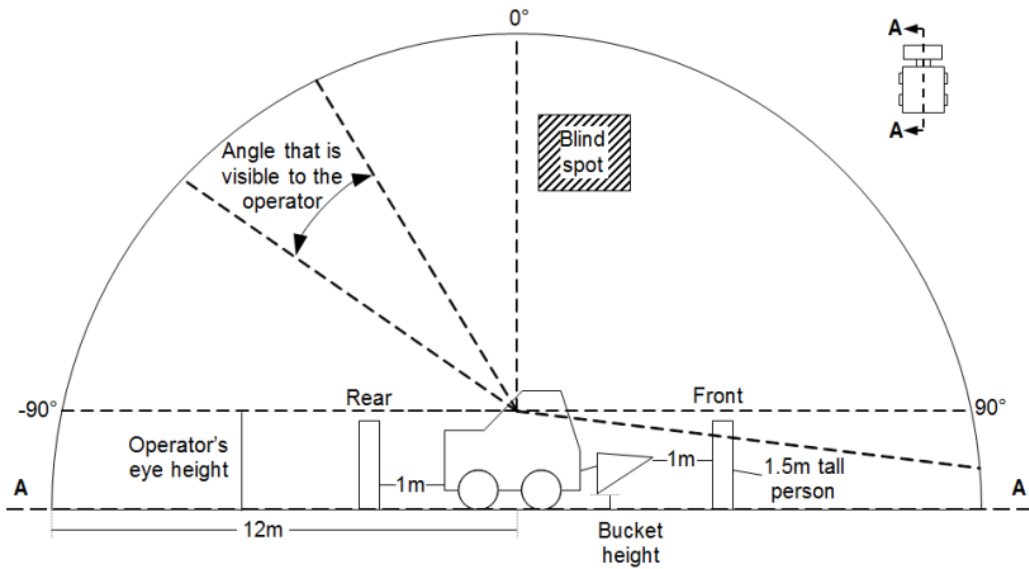

Figure 16: Reading the side view diagram (same for front/rear and left/right views)

5.4.4 Allocation of the Design Inefficiencies

Four different models of skid steer loader of different manufacturers were evaluated for equipment operator visibility. Many design details were incorporated into the blind spot measurement. For example, most skid steer loaders are designed with a metal grid around the operator's cabin to prevent any worker to be pinned by the hydraulic arms. This metal grid was included in the blind spot measurements to evaluate its effect on the operator's visibility. By evaluating different models of the same construction equipment, design characteristics for each model can be assessed and design suggestions that promote safety can be realized. Other pieces of construction equipment were also measured and are shown in Appendix B.

5.5 Experimental Results and Discussion

The experiments were conducted outdoors in an open environment. Each skid steer loader was placed on a flat concrete slab with no visual obstructions within a 12 meter radius of the equipment cabin. The experiments were conducted during the daytime hours with no precipitation. The skid steer loaders and 3D laser scanner were static during the blind spot measurement experiment.

The four models of skid steer loader selected for blind spot measurement had different structural features. The structural features of each skid steer model evaluated are the number of lift arms, entrance and exit locations, mobilization method, and window type. Different features can create different visibility situations for the equipment operators. The same bucket was used for all measurements. The experimental results show figures obtained from the blind spot measurement tool and summary tables that

give numerical values of equipment operator visibility. Operator visibility measurements for other pieces of construction equipment are shown in Appendix B.

5.5.1 Plan View Visibility

Figure 17 displays the plan view of the laser scans for the four different models of skid steer loaders. The hatched areas denote non-visible areas to the skid steer loader operator. The color represents the reflectivity of the laser scanner signal, but has no impact on operator visibility. The size of the blind spot and the impact of any physical cab structure, including the metal mesh that previously was mentioned, can be seen. Skid steer loaders that have only one mesh (model C) or no mesh (model D) give higher operator visibility.

Table 10 shows the visibility data calculated from the blind spot evaluation of each skid steer loader. The characteristics to each piece of equipment are available at the bottom of Table 10 for comparison. Numbers A through F, that are generated by the blind spot measurement tool, are used to demonstrate the size of visible and invisible areas to an equipment operator. To compare the different skid steer loaders, for example, the size of how much of the circumference is visible to an equipment operator are compared. These calculations then lead to the percent of blind spots.

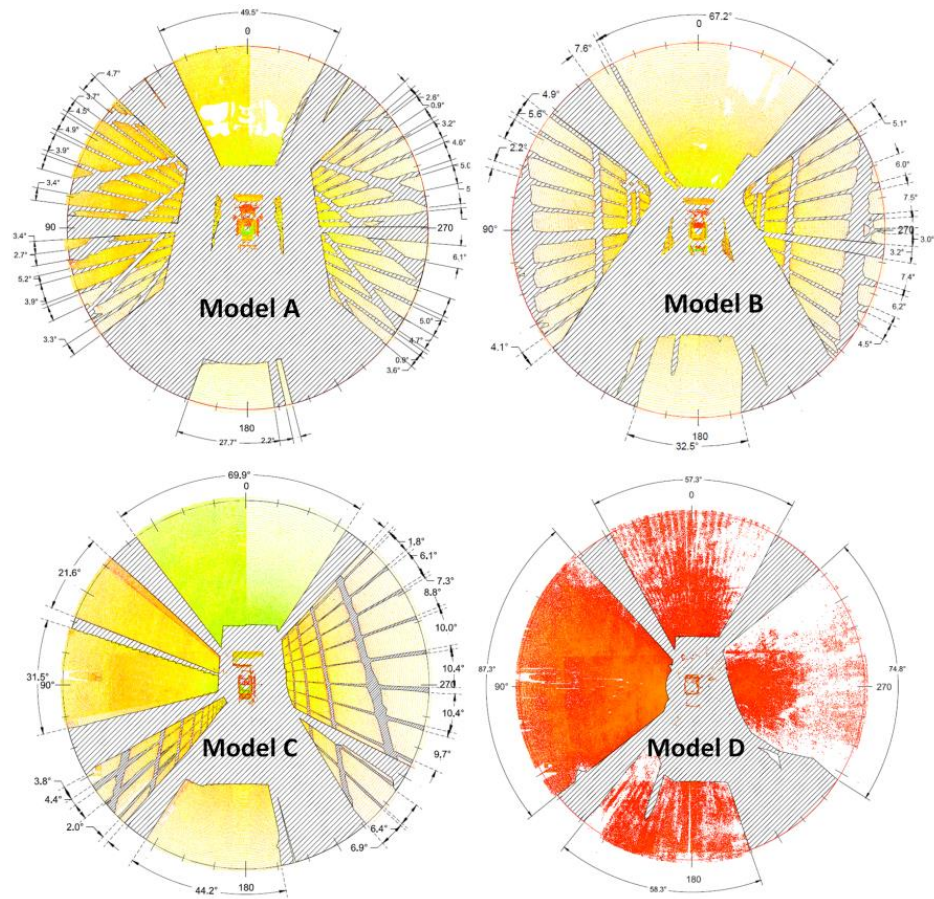

Figure 17: Plan view of laser scan data for different skid steer loader models

Table 10: Visibility data from the plan view of each skid steer loader

Item	Model A	Model B	Model C	Model D
Area of full circle (A)	452.2 m ²	452.2 m ²	452.2 m ²	452.2 m ²
Area occupied by equipment (B)	7.6 m ²	6.4 m ²	6.2 m ²	7.1 m ²
Blind spot area without metal grid (C)	211.4 m ²	178.1 m ²	142.2 m ²	134.2 m ²
Blind spot area with metal grid (D)	268.1 m ²	236.9 m ²	167.9 m ²	134.2 m ²
Visible length of 12 m circumference (E)	34.7 m	43.4 m	53.3 m	58.1 m
Length of entire circumference (F)	75.4 m	75.4 m	75.4 m	75.4 m
Percent of visible circumference [E / F]	46.1 %	57.6 %	70.8 %	77.1 %
Percent of blind spot [C / (A – B – C)]	47.6 %	40.0 %	31.9 %	30.2 %
Percent of blind spot [D / (A – B – D)]	60.3 %	53.2 %	37.6 %	30.2 %
Number of lift arms	2	2	1	1
Entrance and exit locations	Front	Front	Side	Side
Mobilization	Tires	Tires	Tires	Tracks
Window type	Metal grid	Metal grid	Metal grid and glass	Glass

5.5.2 Front and Rear View Visibility

The diagrams in Figure 18 depict the operator visibility of the four different skid steer loader models through a detailed (A-A) view shown in Figure 16. They show the operator's visibility of a 1.5 meter tall person at one meter distance at the front and the rear of the skid steer loader. The best performing equipment in front view is model D since 83% of a person standing in the front of the equipment is visible. The best performing equipment in rear view is model C with 31% visibility. The numbers in parentheses denote the total percent visibility in front and rear view. For example, an equipment operator in model D can see 34% in the front/rear perspective (also referred to the A-A view). This percentage includes the sky light at the top of the equipment cabin.

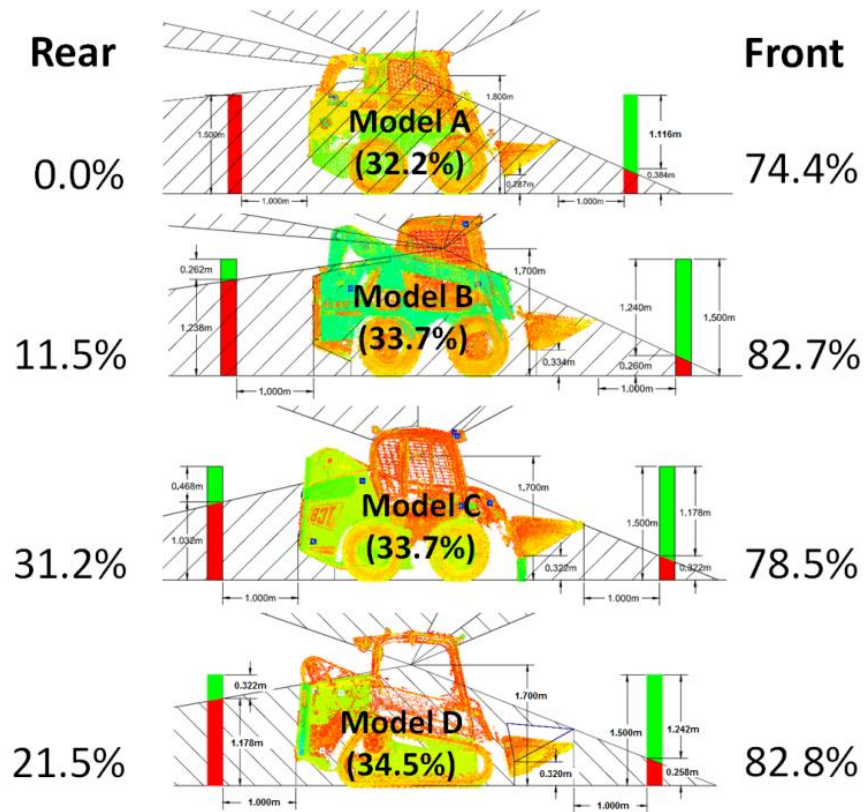

Figure 18: Rear and front view of laser scan data for different skid steer loaders

5.5.3 Side View Visibility

The diagrams in Figure 19 depict the operator visibility of the four different skid steer loader models through a detailed (B-B) view as shown in Figure 15. They show the operator's visibility of a 1.5 meter tall person at one meter distance at the left and right of the skid steer loader. The best performing equipment in front view is model D since 100% of a person standing to the left is visible. The best model with view to the right has model D with 65% visibility. The numbers in parentheses denote the total percent visibility in left and right view. For example, an equipment operator in model D can see 62% in the left/right perspective (also referred to the B-B view). This percentage includes the sky light at the top of the equipment cabin.

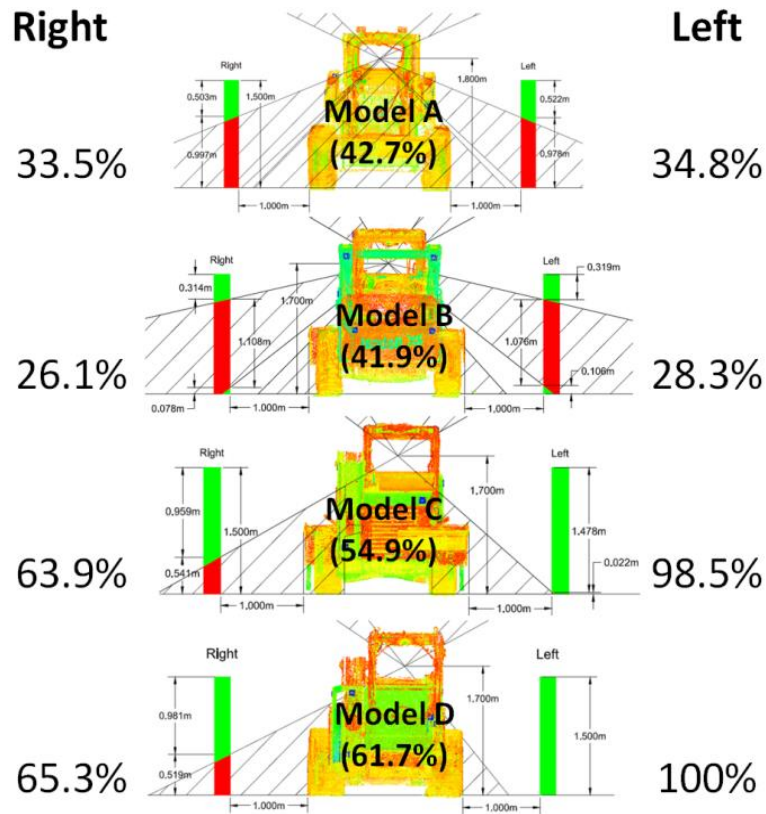

Figure 19: Side view of laser scan data for different skid steer loaders

5.5.4 Summary of Results

Table 11 presents more data collected for each piece of skid steer loader. The bold values indicate the highest allowed operator visibility when compared to the other models measured. All italic numbers indicate a measurement that was close (less than 2%) apart from the highest visibility measurement. Table 11 summarizes the results of blind spot measurements projected onto the plan, front and rear, and side views for all skid steer loader models evaluated.

Model D had the best overall operator visibility and the least percentage of blind spots. Structural features such as a glass enclosed equipment cab or only one hydraulic arm could account for these visibility rates. Model D also has the best operator visibility

for an object in front of the equipment, followed closely by model B. Model D boasted the highest sum of all visible angles in the front/rear view, possibly because of the glass enclosed equipment cab.

Model D has the greatest sum of all visible angles on the side view followed closely by model B and model C. Model C had the greatest visibility on an object in the rear of the equipment. This could be attributed to the sloped rear panel behind the equipment's cab and the lack of a second hydraulic arm bracket in the rear of the equipment. In the side view, Model D had 100% visibility for an object on the left side of the equipment because it only has one hydraulic arm located on the right of the equipment. Model C has the similar single hydraulic arm configuration, and it experienced 98% visibility on the left side. Model D had the highest visibility on the right side of the equipment followed closely by model C.

Table 11: Summary of results for all skid steer loader models

	Model A	Model B	Model C	Model D
Number of lift arms	2	2	1	1
Entrance/exit locations	Front	Front	Side	Side
Mobilization	Tires	Tires	Tires	Tracks
Window type	Metal grid	Metal grid	Metal grid and glass	Glass
Area occupied by equipment	7.6 m ²	6.4 m ²	6.2 m²	7.1 m ²
Blind spot area (no metal grid)	221.4 m ²	178.1 m ²	142.2 m ²	134.2 m²
Percent of blind spot (no metal grid)	47.6%	40.0%	31.9%	30.2%
Blind spot area (metal grid)	268.1 m ²	236.9 m ²	167.9 m ²	134.2 m²
Percent of blind spot (metal grid)	60.3%	53.2%	37.6%	30.2%
Sum of the lengths on the 12m circumference that are visible	34.7 m	43.4 m	53.3 m	58.1 m
Percent of the lengths on 12-m circumference that are visible	46.1%	57.6%	70.8%	77.1%
Visibility of an object in the front of the equipment	74.4%	82.7%	78.5%	82.8%
Visibility of an object in the rear of the equipment	0.0%	11.5%	31.2%	21.5%
Sum of all visible angles in the side view	116.2°	121.6°	121.6°	124.2°
Visibility of an VTP on the left side of the equipment	34.8%	28.3%	98.5%	100.0%
Visibility of an VTP on the right side of the equipment	33.5%	26.1%	63.9%	65.3%
Sum of all visible angles in the front view	153.8°	151.1°	197.8°	222.2°

Model C has the smallest equipment footprint at 6.2 m² and model D had the smallest blind spot area. This model skid steer performed best both with and without considering the metal grid around the operator cab. The skid steer models C and D replaced most or the entire metal protective grid (respectively) for an enclosed clear cabin casing. This allowed for better operator visibility simply because there was no metal grid blocking the operator's LOS.

The sum of all lengths that are visible in the 12 meter VTC circumferences ranged from 34.7 m (46%) to 58.1 m (77%). Higher values of the VTC circumferences are more

desirable because they show a higher visibility along the circumference. Model D had the highest VTC circumferences at 58.1 m or 77%.

Model D had the highest visibility percentage (8%) of an object with a 1.5 meter height and at a distance of one meter from the front of the equipment followed closely by model B with 83%. Model C was the skid steer loader with the highest visibility at 31% of an object of 1.5 meter height and at one meter distance from the back of the equipment. The sum of all visible angles from the operator's perspective from the front or rear ranged from 116.2 degrees to 124.6 degrees. Model D and model B tied for the highest visible angles at 126.6 degrees.

The skid steer loader with the highest percentage of visibility of an object to the left side was model D at 100% followed by model C at 98%. Likewise, the maximum visibility of an object to the right side was 65% by model D followed closely by model C. The summary provided in Table 11 indicates that skid steer loader models evaluated with clear glass enclosed equipment cabins, only one hydraulic lifting arm, and slanting rear panel demonstrated the best operator visibility and the least amount of blind spot areas and spaces.

5.5.5 Design Recommendations

The blind spot measurement data presented provides valuable insights on how the design of skid steer loaders (and construction equipment in general) impacts equipment operator's visibility. The experimental results can be analyzed to determine which design features provide the optimal visual situation for the equipment operator.

Best design practices for skid steer loaders based on the collected blind spot data are recommended. Many countries require that equipment manufacturer release blind diagrams before they can be commercially sold. Although Computer Aided Design (CAD) data might be used to optimize equipment design, equipment is often modified in the field. Since equipment is often altered in the field, measurement practices as suggest in this research, should be repeated regularly. They help equipment operators understand blind spots even with an equipment the operators might be very well familiar with already.

The four skid steer loaders used for experiments all had different design characteristics. For example, models C and D were equipped with an operator side entrance while the other models have a front entrance. This very recent design change eliminated the dangerous front entrance for the operator above the skid steer loader's bucket. Other models (for example, A and B) have an operator climb into the cabin from the front. This is simply an unfeasible practice by design, since operators potentially can trip over debris in the bucket or slip on flat but sharp metal surfaces caused by small hydraulic oil leakages.

Models A and B have two hydraulic lifting arms, while model C and D only have one. By eliminating one hydraulic arm, visibility was greatly increased on one side of the skid steer loader. Every skid steer model had rubber tires except for model D which used rubber tracks. The influence of rubber tracks on the results was insignificant because of their low mounting position. Each model of skid steer loaders has different design elements such as the number and location of hydraulic loading arms. These design differences create different blind spot and visibility angles for the equipment operators.

From the blind spot measurement data and research findings, one can conclude that equipment design has a profound impact on blind spots of the equipment operator's visibility. The following observations can be made from the data collected:

- By substituting a clear enclosed equipment cabin for the existing metal grid, the skid steer loader operator experiences better visibility.
- Skid steer loaders equipped with two hydraulic loading arms provide better visibility for operators when the hydraulic arms are positioned lower than the operator's cab window.
- One hydraulic arm instead of two allows for better visibility of objects on the side of the skid steer loader.
- Large rear viewing windows and minimal obstructions on the rear allow the operator greater visibility of objects behind the equipment.
- The rear panel of the equipment should be lower than the equipment cabin viewing window and slanted downward to provide the maximum visibility.
- Skid steers are often used to lift materials above the height of the equipment. Operator visibility above the equipment cabin is imperative for safely loading and dumping materials. While maintaining the proper ROPS and FOPS systems, minimum obstructions at the top of the cabin increase visibility for the operator.
- Equipment designers and manufacturers should be aware of typical blind spot areas and attempt to minimize the safety hazard through design characteristics of the skid steer loader.

- A blind spot measurement practice that is simple to use can provide reliable blind spot diagrams, in particular for equipment that has been modified in the field. Regulations and standards should address emerging technologies that allow for safer equipment design, manufacturing, and utilization.

5.5.6 Validation

Visibility results from laser scanning were compared to the previously used light bar visibility measurement method [200]. Two models of steel drum rollers from the same manufacturer that were comparable in ground surface area coverage, operator position including height, and cab obstructions were compared using the measured blind spot area and the visible length circumference. Although the two rollers were not the same model, most of the equipment specifications were the same or very similar. The individual measurements and percent differences can be viewed in Table 12.

Table 12: Operator visibility measurement results from different measurement methods

Type	Model	Measurement Method	Blind Spot Area	% Difference	Visible Length Circumference	% Difference
Roller	Cat CB 534D	Light bar	51.4 m ²	12.4%	74.2 m	3.8%
	Cat CB 534C	Laser scanning	57.8 m ²		71.4 m	

5.6 Conclusions

Construction equipment fatalities account for approximately 25% of the total fatalities experienced in the construction industry [62]. A leading cause of these fatalities

is poor operatory visibility including blind spot areas which contribute to about half of the visibility-related fatalities in construction. The blind spots are created when an equipment operator's LOS is obstructed by an object on both the construction equipment and in close proximity of the equipment. Many types of construction equipment are capable of numerous articulations which can create additional (or so called dynamic) blind spots for the equipment operator. Furthermore, the characteristics of a construction sites require that workers, material, and construction equipment operate in close proximity which can enhance the existing visibility issues for equipment operators. Any visibility-related issue including blind spots can create unsafe working conditions and can lead to injuries or fatalities.

The major contribution of this chapter is a blind spot measurement technique based on laser scanning that follows existing international safety standards, but requires less effort and provides higher accuracy compared to existing manual techniques. These advantages were capitalized to measure the blind spots of four skid steer loaders. The resulting 3D blind spot diagram for each piece of equipment reflects the individual equipment design. The smallest blind spots for each equipment type represented the best design to promote safety while maintaining the highest operator visibility of the surrounding equipment work space.

This work was limited in scope. Many equipment manufacturers now measure operator visibility using design software which does not require laser scanning or infrastructure to measure operator visibility [63]. The method presented in this chapter is more applicable to older construction equipment where no design model is available or construction equipment that has been modified in the field. A future study could

investigate and validate visualization of operator visibility through design software versus laser scanning or other applied operator visibility measurement methods.

Another limitation of the research presented in this chapter is the absence of rear-view mirrors. Rear-view mirrors are used as aids for equipment operators to visualize blind spot areas around the equipment. For this study, enhanced operator visibility from mirrors was not included in the blind spot measurement data. For further research, the impact of mirrors could be integrated into the operator visibility data. Although a laser scanner provides accurate 3D data even in small equipment cabs, a more complete validation of the approach including a scientific evaluation of the current standard measurement method is needed.

CHAPTER 6

SELECTION OF TECHNOLOGY FOR PROXIMITY DETECTION AND ALERT SYSTEMS FOR CONSTRUCTION EQUIPMENT OPERATION

This chapter discusses the needs for a real-time proximity detection and alert system for construction sites. A summary of potential technologies and their applications is presented. Radio Frequency Identification (RFID) was identified as a candidate technology and was further tested through experimental trials. Numerous field experiments were designed and conducted to emulate typical interactions between workers-on-foot and construction equipment. Occurrences of proximity breaches were also recorded and analyzed to identify hazards on construction sites.

6.1 Introduction

Each construction site is characterized by a unique size and set of working conditions. Construction work environments are comprised of a mixture of multiple construction resources such as site personnel, equipment, and materials. Each of these resources performs a multitude of dynamic construction activities in a defined space and often requires they operate at close proximity to each other. When construction equipment is operating in close proximity to ground workers, a hazardous situation can be created. Contact collisions between ground workers and heavy construction equipment can increase the risk of injuries and fatalities for construction personnel.

Previous researchers have investigated the proximity issue in construction including injury and fatality statistics of collisions between construction equipment and workers. Because construction activities often involve many repetitive tasks, construction workers can experience decreased awareness [55]. A real-time proximity detection and alert system is needed on construction sites to warn equipment operators of hazardous proximity situations.

Real-time safety technologies implemented on construction sites have been found capable of providing alerts to ground workers and construction equipment operators in real-time when a hazardous proximity issue is present [130]. These technologies can create a safety barrier and provide workers a “second chance” if another safety best practice is disregarded [130]. Some of these technologies are also capable of recording safety data that currently is not obtainable, such as near misses. By identifying and recording this data, new information sources are available to enhance construction safety. Currently, safety data collections are manually completed and are subject to human error [131]. However, several research ventures have investigated remote sensing technologies for potential use for material management strategies within the construction industry [132][133][134][135].

A lack of scientific evaluation data currently exists for construction safety technologies such as proximity detection and alert systems including limited testing methods for evaluating these systems. Minimal information and data currently exists to evaluate how existing construction safety technologies can be implemented to warn construction personnel of the presence of hazardous proximity situations. Experiments designed to emulate the construction environment are required to evaluate these emerging

safety technologies. Data retrieved from these experiments can be used to demonstrate the validity and effectiveness of these safety technologies.

Historically, construction companies have been slow to implement new technology and innovation in comparison to other industries [136]. When technology is implemented, standards are created for system manufacturers as well as construction companies who are the end users [137][138]. Other industry sectors in the U.S., such as underground mining and railroad operations, have tested and began implementing various proximity detection technologies [130][139][140][141][142][143][144][145][146]. As demonstrated by these industry sectors, emerging safety technologies including real-time proximity detection and alert systems can be used to provide ground workers with alerts during hazardous proximity situations.

6.2 Background

A review of current construction safety practices specific to hazardous proximity issues is discussed. Technologies thought to be capable of providing alerts in real-time during hazardous proximity situations were reviewed specifically for their effectiveness to perform in the construction environment.

6.2.1 Current Safety Best Practices

Standards and regulations mandated by OSHA are imperative to improve safety in construction [147]. For example, during hazardous proximity situations, OSHA requires construction equipment to provide alerts when moving in the reverse direction [148]. These alerts can often desensitize workers by alerting workers when hazardous

conditions are not present [149][150][151]. Back-up alerts, along with other safety strategies, are incapable of preventing contact collisions between workers and construction equipment. Current safety regulations also require safety devices such as hard hats, reflective safety vests, and other personal protective equipment (PPE) [148]. These passive safety devices are incapable of alerting construction operators and workers in real-time during hazardous proximity situations. Other safety regulations such as safety training and education can increase the awareness of close proximity issues for construction operators and workers [32][40].

Much research has been performed with regards to safety behavior of construction workers [39][152][153]. CII monitored construction workers and later provided suggestions about safe and unsafe practices that were observed. The method provided near real-time feedback during the monitoring period for the construction workers [153]. Companies that implemented site-specific safety programs early in the project were found to experience better safety records than companies that did not [39]. The study found that increased efforts in front-end planning including design for safety can improve safety on construction projects.

6.2.2 Real-time Proximity Detection and Alert Terminology and Methods

Proximity detection and alert systems were evaluated based upon their feasibility to work in a construction environment, including cost, operating distance, and other parameters characteristic to construction projects. Excluded were technologies that are in the prototype stage, such as emerging range imaging technology [154][155][156]. The evaluated technologies include RFID, Ultra-Wideband (UWB), GPS, magnetic field

sensing, vision detection devices including video cameras, mesh radio systems, laser, sonar, and radar based proximity warning technologies. In order to evaluate these technologies effectively, defined the terminology was defined to understand the similarities and differences between each device [130].

- A proximity detection system is a system that detects a person or vehicle using a sensor
- A proximity detection and alert system is a sensing system that provides an alert for equipment operators and ground workers when a hazardous proximity issue is detected
- A collision avoidance system is the processing of data to information that results in signals or actions that alter equipment movement in an attempt to prevent a collision
- Real-time is defined as highest possible signal update rate
- Pro-active means a device that can warn workers or systems before accidents occur and have the potential to avoid incidents

All technologies researched in this report are considered proximity detection or alert systems; however, few of these are classified as a true collision avoidance system. Each proximity detection and alert system technology can be characterized as a control technology, independent (stand-alone), cooperative system or a network system. The following categories are defined [157]:

- Control technology: A system that provides an equipment operator with more information (e.g., visually through mirrors or larger windows)
- Independent (stand-alone) technology: A system that detects objects through sensing, but is incapable of identifying the location of the detected object. This technology is considered a passive system (e.g. back-up alarms)
- Cooperative technology: A system that uses sensing and detection devices which communicate with each other. These devices are worn by workers and one component of the system is also placed on each piece of construction equipment
- Network technology: A system that utilizes cooperative technology with other infrastructure pieces that allow all devices in the system to communicate with each other

Different proximity detection and alert strategies exist and range from equipment operators and ground workers being alerted by an audible, vibration, or visual alarm to an entire piece of equipment shutting down because a worker is in too close proximity of that piece of equipment. Many of these devices use a combination of visual alerts, vibrating devices, flashing lights and audible alarms [105]. Some devices come for entire work crews and do not require equipping each worker with a device. The alert strategy mainly depends on the equipment and the site environment.

6.2.3 GPS Based Proximity Warning

GPS provides positioning information to workers, equipment, and materials. Past research has integrated GPS systems into construction equipment for safety zone hazard

analysis [158][159]. It uses antennas, receivers, and processors that communicate with satellites to determine a point location. This technology is considered a network system because the detection information is shared with all devices in the system and it requires infrastructure. The information is shared between all construction equipment through radios concerning safety exclusion zones, equipment location and path calculations to determine a potential collision area [157]. Other research has utilized GPS technology for tracking and locating construction materials [160]. Figure 20 depicts the different components of a GPS system on a construction project.



Figure 20: GPS based proximity warning technology [157]

It is possible to also equip construction workers with GPS devices, although high precision GPS devices for workers are relatively expensive when compared to other proximity detection and alert devices. The location of each piece of construction equipment is coupled with proximity warning and alert mechanisms. Based on too close

proximity (distance between two pre-defined objects is too small) the warning or alert is activated. Some GPS systems have the capacity to add coordinates and perform path calculations for construction equipment. By outlining a potential equipment path, workers can be notified of common travel ways of heavy equipment and thus avoid these areas.

One major drawback of GPS is the high initial equipment cost. For most construction sites, the equipment cost is too expensive to be feasible to track every piece of construction equipment. Attempts have been made to combine GPS technology with other sources to decrease the overall project cost for using the GPS system. Combining RFID readers equipped with GPS technology [133] reduced the implementation costs, but problems with the detection range and number of passes required to identify the location were still present [161][162]. Another main drawback to GPS locating technology is its inability to locate objects underground or inside a building. The GPS satellites are most effective in locating objects on the ground surface with no obstructions (such as a tree or roof) between the object and the satellite. Additionally, GPS systems are unable to detect specific construction workers on foot. In order to be an effective proximity warning device, a network system must be small and cost-efficient enough to detect and communicate with every construction worker [157].

6.2.4 Magnetic Marking Fields

The most dominant proximity detection technology used in a construction related field of underground mining is magnetic marker fields. This cooperative system uses a tag-based system of two-way communication between systems installed on mining equipment and detectors on mine workers. The magnetic marker field is generated by the

device either on the mining equipment or the worker, and its purpose is the monitor hazardous areas [157][161][162]. Figure 21 demonstrates the magnetic marker field being generated by a device located on the worker's arm.

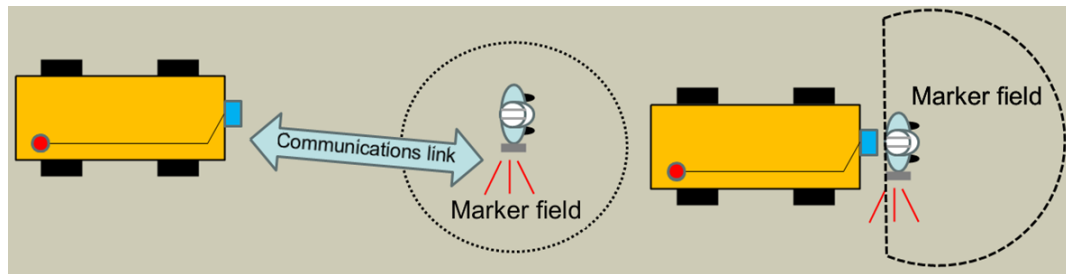

Figure 21: Magnetic marker field generated on the worker and by the equipment

[157]

The signals are projected using very low frequency (VLF) or low frequency (LF) spectrum magnetic field. In other systems, very high radio frequency (VHF), ultra high frequency (UHF) or even a combination are used to generate the magnetic field. The readers are capable of detection, calculating distance between signals and identifying the source of the signal whether it is worker or equipment. The reader is able to calculate the distance through reading the signal strength; the greater strength means the source is close.

NIOSH has developed a specific type of magnet marking field named the Hazardous Area Signaling and Ranging Device (HASARD). Because HASARD is an active system, it eliminates many nuisance alarms that are prevalent with passive proximity warning systems [165]. Many proximity systems with similar capabilities require a transmitter to be installed on one object and a receiver to be installed on another

object. On construction sites, the transmitter would be installed on a large piece of equipment and the receiver on a worker. This would allow the transmitter to detect the proximity of workers-on-foot and potentially avoid accidents. Receivers can be installed on things other than workers as well including road edges, poles, manholes, etc. This system allows for remote alarms, data logging and equipment shut-off features [165][166][167][168][169]. When a construction worker enters the magnetic field signal at a certain level, a detection alarm is triggered to the operator.

6.2.5 Radar Based Proximity Detection and Warning

Another proximity detection method uses RADAR (Radio Distancing And Ranging) to warn equipment operators of a construction worker nearby. RADAR is classified as an independent (stand-alone) system because it is typically incapable of identifying the type of object it is detecting. RADAR can sound the same alarm types if it detects a rock, tree, or worker. Typical RADAR alerts consist of an audible or visual warning, and some systems have incorporated both. Many of the systems are also coupled with an optional camera system that allows the driver to see what is in the RADAR beam area. A RADAR based proximity detection system emits a pulsed or continuous wave from the construction equipment. Multiple antennas can be positioned on the equipment to monitor the blind spot areas [157]. A depiction of a radar based proximity detection system is shown in Figure 22 for a haul truck.

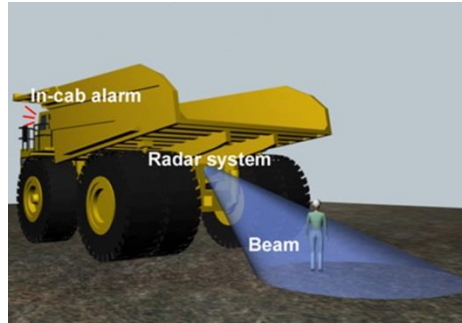

Figure 22: Radar based proximity detection system for a haul truck [157]

RADAR was found to be well suited for slow moving scenarios with short ranges (8 to 20 meters) [157]. Equipment mounted RADAR system can also be used for very short range object tracking up to 8 meters. Due to the range limitations, RADAR offers a feasible solution for smaller construction equipment. RADAR systems have also been found to occasionally produce a false alarm which can desensitize workers [157][170].

6.2.6 Mesh Radio System

Using redundant positioning technologies, mesh radio networking detection systems are mainly used in the mining industry. This system requires a wireless mesh node on each piece of equipment enabling each node to act as an independent router. The radio signal moves from one node to the next through a dynamically interconnected system. The radio signal allows the entire vehicle fleets to communicate to their respective vehicle location information. As different pieces of equipment move in and out of range, the signal changes paths and uses signal strength to calculate distance between objects. Full knowledge of the position, velocity and heading of all vehicle units in the area become possible [171].

“Caution” notifications are given to the operator when units are detected within a certain distance allowing the operator to be aware of the potential hazard. “Alert” notifications are also given to the operator when the situation calls for the operator’s immediate attention. The “Caution” and the “Alert” radii are configurable and dynamic meaning they can change with the location in the mine and speed of the equipment. For example, hauling trucks can have various alert zones throughout a work day depending on the construction operation and driving speed.

This multi-sensor positioning gives the equipment operators situational awareness that is not just limited to GPS-equipped mobile equipment. That means the system has the power to reveal personnel working under haul trucks or even a mechanic in an engine compartment. Operators can be notified of potentially unsafe situations by way of a two color light bar that can easily be mounted to the dash. As an option, alarms can be installed to heighten awareness of alert situations.

6.2.7 Camera and Vision Technology

Intelligent video systems, as shown in Figure 23, can be used as a proximity warning device [146]. Computer-assisted stereovision cameras are capable detecting obstacles using 3D position information [172]. The camera gathers information and develops a 3D point cloud of the object detected. This technology has decreased in cost in the past few years [157][173]. Vision has been implemented in construction in other capacities including tracking construction resources and site progress monitoring [174][175][176][177][178][179].



Figure 23: Rear-mounted camera and on-board screen to cover rear blind spots

[130]

It was concluded that camera technology is capable of simultaneously providing two types of safety information: 1) Proximity detection and 2) blind spot visualization [157]. Closed Circuit Televisions (CCTV) installed inside construction equipment are connected to rear-mounted cameras so that operators receive a real-time visual image of the blind spot directly behind the equipment.

Video cameras were found to be most beneficial when combined with other methods such as RADAR. Once alerted, the video camera allows the operator to see exactly what object is in the blind spot. A major disadvantage of having a screen of the video camera systems in the driver cab is that it can distract the equipment operator from its work task. Also, visibility of a camera system is limited during night time operation and when the camera lens is obstructed by dirt or dust.

6.2.8 Radio Frequency Proximity Detection

A need exists in the construction industry for a wireless, reliable and rugged technology that can identify the location construction workers, equipment, and materials. Technology with these specifications is also needed to provide a warning and alert signal

in real-time for construction workers in dangerous situations. Radio Frequency (RF) technology has proven to meet these construction jobsite requirements for safety [130][180][181].

RFID has been used in many capacities in other industrial sectors, and recently has entered the construction domain. Passive and active RFID tags have been used to monitor workers as they pass along the entry bridges to ships [179], in material and logistic efforts [162][183], site access [184], and also related to site safety [185][186]. RFID tags can store important security information about workers and enable an easy accounting mechanism of workers or search and rescue personnel during emergency situations [187].

RFID technology has been applied as a warning device in other industries as well. In manufacturing industries and warehouses, forklifts are required to operate in small spaces. To alert ground workers, UHF devices have been placed at corners that trigger an alarm when a forklift is in the proximity of the sensors. This technology allows for large mining equipment or small forklifts in warehouses to be tracked and monitored throughout the warehouse in an attempt to locate any potential dangerous situations [188][189]. RF technology is also used in the railroad construction [190] and alerts ground workers of hazards at recycling centers [191].

Active RF technology uses VHF to project omni-directional signals into the field. Typically an antenna and battery is installed on the equipment or inside the equipment cab. A worker or crew is equipped with an individual or crew warning and alert device that triggers if the distance between personal devices and equipment mounted devices are closer than the pre-calibrated alert range. RF technology can:

- Activate real-time alert for operators
- Provide a pro-active tool for managing risk
- Add another layer of protection in the safety system
- Operate (intrinsically) safe in most construction working environments
- Easily transfer to other workers or to install on other pieces of equipment

Some of the main limitations of RF technology include:

- Requires a power source
- Requires installation on workers, crews, and equipment
- Is impacted by vehicle and environmental effects through RF multipath and site obstructions (see Figure 24)

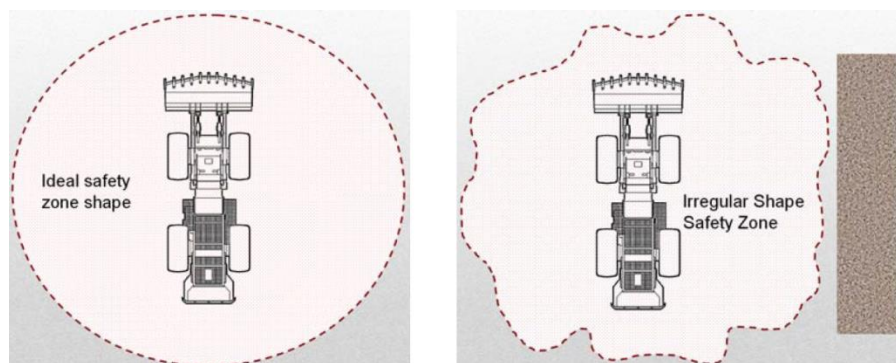

Figure 24: Ideal case including open, unobstructed, flat surface (left), Vehicle and obstructions influence on signal propagation (right) [189]

6.2.9 Proximity Detection and Alert Technology Selection Summary

A variety of proximity detection and alert technologies exist for a many applications. Most come with greater benefits that exceed the limitations. Some of these limitations need to be explored further, for example, measuring the proximity distance of the alert device, its coverage area, and the reaction of workers to the alert signal. Among other important tasks, an implementation strategy, investment in safety analysis (cost-benefit), and some legal aspects should also be explored before technology becomes widespread in the construction industry. Table 13 provides a summary of the review of candidate technologies for proximity detection and alert systems in the construction environment.

Table 13: Summary of evaluating proximity detection and alert technology

Technology needs to work from and for:	<ul style="list-style-type: none"> • Person to equipment • Equipment to equipment • Equipment to work area • Area access control • Single worker or equipment to multiple crew or equipment fleet • Various equipment speeds and trajectories • Obstacle avoidance or stop movement of equipment
Available technologies for proximity detection and alert systems:	<ul style="list-style-type: none"> • (Stereo) Vision camera systems • Infrared • Ultrasonic • Magnetic field marking • Radar based systems • GPS • Lasers • RF tagging
The success and effectiveness of technology is impacted by:	<ul style="list-style-type: none"> • Distract driver • Constant cleaning • Heat or noise from equipment • False and nuisance alarms • Indoor environments • (Fixed) sensing infrastructure • Reliant on reflective surfaces (e.g. metal) • Varying alert ranges • Prototype stage and not fully evaluated
Wireless technology shows the least limitations in a typical construction environment:	<ul style="list-style-type: none"> • Operates in smoke, dust, and rain • Does not distract driver from normal operations • Real-time data collection • Safety zones are adjustable • Mobile technology

Table 14 summarizes the benefits and limitations identified from the review of technologies though to be capable of providing an alert to workers and equipment operators during hazardous proximity situations.

Table 14: Benefits and limitations of candidate proximity detection technologies

[144][192][154][193][194][195][196][197][198]

Technology	Benefits	Limitations
GPS	<ul style="list-style-type: none"> • Minimal required infrastructure • Can function on outdoor sites without overhead obstructions 	<ul style="list-style-type: none"> • Not functional indoors • Not suited for short range detection
Laser	<ul style="list-style-type: none"> • High signal update rate • Capable of functioning in the construction environment 	<ul style="list-style-type: none"> • Not able to identify a ground worker from other objects • Only accurate for short range detection
RADAR	<ul style="list-style-type: none"> • Capable of multiple antenna integration • Can be used to supplement video 	<ul style="list-style-type: none"> • Not able to identify a ground worker from other objects • Only accurate for short range detection
Sonar	<ul style="list-style-type: none"> • Minimal infrastructure required • Low initial cost 	<ul style="list-style-type: none"> • Minimal detection range • Susceptible to elements in the construction environment
UWB	<ul style="list-style-type: none"> • System can identify a ground worker from other objects • Can function on outdoor/indoor sites 	<ul style="list-style-type: none"> • Sizeable amount of infrastructure • High initial cost
Vision	<ul style="list-style-type: none"> • System can identify a ground worker from other objects • Capable of detection at various ranges 	<ul style="list-style-type: none"> • Poor visibility at night or in dusty areas • Line-of-sight segmentation

6.2.10 Proximity Detection and Alert Systems Testing

Several past research ventures have incorporated methods to evaluate the capabilities of proximity detection and alert systems. A camera and radar systems were mounted on a large capacity haul truck and proximity alert distances were manually marked and measured on the ground surface [205]. Trials included several activities typical of a large capacity haul truck in copper mining environments. The system detected obstructions approximately 30 feet in front and behind the haul truck.

A similar experiment deployed GPS systems on large capacity haul trucks and a base station was located on a nearby hill [173]. Several trials were performed to test the accuracy of the system to track three mobile vehicles and six stationary objects. The system was able to track all vehicles and objects while the haul truck performed typical activities in a surface mining environment. Other research integrated computer-assisted stereo vision with a radar detection system to potentially realize the benefits of a combined proximity detection and alert system [206]. Stereo cameras were mounted on the rear of an off-highway dump truck. Several field trials positioned a person and berm in the path of the truck to evaluate the system's proximity detection and alert capabilities.

6.3 Objective and Scope

The primary objective was to evaluate the reliability and effectiveness of a RFID proximity detection and alert system in the construction environment. This system was previously identified as a potential candidate technology to provide alerts during hazards. The system should provide an alert in real-time to ground workers and construction equipment operators during hazardous proximity situations. When construction resources are in close proximity to one another, the sensing technology will detect the hazardous condition and activate an alarm to warn equipment operators through devices called Equipment and Personal Protection Units (EPU and PPU, respectfully). The scope includes proximity issues between heavy construction equipment and ground workers on a level surface on outdoor construction sites.

6.4 Research Methodology

The radio frequency technology proximity detection and alert system was evaluated through several experiments. Each experiment was designed to measure the performance of a proximity detection and alert system in a simulated outdoor construction environment. The set of experiments tested the device's ability to detect and alert equipment operators of hazardous proximity issues while subjected to a simulated and active construction environment.

The first experiment tested the proximity sensing devices in a mobile ground worker and static construction equipment scenario. The PPU was attached to a ground worker outside of the construction equipment and one EPU was placed inside the cabin of each tested piece of construction equipment. The ground worker equipped with the PPU device approached the piece of static construction equipment at a specified distance from many different approach angles. A theoretical safety zone was created by pre-calibrating the proximity detection and alert devices to various alert ranges. Positioning of the EPU device inside the construction equipment cab impacts the proximity range configuration, so the device was placed in a similar location on each piece of construction equipment.

Similarly to the previous experiment, a static ground worker was equipped with a PPU device. An EPU device was installed on one piece of construction equipment. For each experiment, the construction equipment approached the static ground worker at a constant travel speed (16 kilometers per hour). After the alert was activated, the equipment operator halted the piece of construction equipment and the distance between the equipment's stopped location and the static ground worker was measured. Because the proximity distance was measured after the equipment was stopped, the data

represented the minimal distance required to stop the equipment before it struck the ground worker.

Each of the experiments was designed to evaluate a specific characteristic of the construction environment. The methods used for measuring proximity alert distances and data collection were held constant for all experiments. All OSHA construction safety regulations were followed while conducting experiments on active construction sites and only qualified construction equipment operators were used for testing.

6.5 Experiments and Results

Each experiment was designed to evaluate the effectiveness of the tested proximity detection and alert system in the construction environment specifically to provide alerts to construction personnel when hazardous proximity situations exist between construction equipment and ground workers. Each experiment attempted to simulate functional characteristics of a typical construction site. The proximity detection system utilized for the experiments used a secure wireless communication line of VHF at approximately 434 MHz.

6.5.1 Technology Tested

RF technology was implemented for the proximity detection experiments. The system is made up of an in-cab device (EPU) for construction equipment and a personal device (PPU) for ground workers. The EPU device contains a single antenna, reader, alert mechanism and can be connected to the central power source of construction equipment. The PPU device consists of a chip, battery, and alarm and can be installed on the hard hat

of a construction worker. A signal broadcasted by the EPU is intercepted by the PPU when the devices are in too close of proximity which is defined by the calibrated alert distance. The signal is broadcasted by the EPU in a radial manner through an omnidirectional antenna and loses strength as the distance increases from the EPU location. The proximity range can be manually modified by the user to lengthen or shorten the range of which an alert is activated. When the PPU intercepts the radio signal, it immediately returns a signal and an alert is activated from the EPU in real-time.

These proximity detection devices used have two different alert methods. Construction equipment operators in a hazardous proximity location can receive a visual and audible alarm. Equipment operators receive an alert through an audible alarm and visual flashing lights located on the device inside the equipment cabin. The audible alert creates enough noise so that operators are able to hear and distinguish the alert. The audible alarm is also different from other sounds and back-up alerts common to construction sites. The visual alerts provide more alert options because the operators can become desensitized to audible alerts. A series of red light-emitting-diodes (LED's) activate upon a proximity breach. These lights are distinguishable among typical construction equipment controls.

The PPU's and EPU's were designed to be durable including sturdy casing capable of withstanding daily weathering. The PPU rechargeable battery power duration is approximately two work days. During the experiments, the proximity detection and alert system demonstrated similar signal strength throughout the battery's duration. A small LED located on the PPU is activated when the device is charged and working. The EPU can connect directly to the battery source of a piece of construction equipment and

also displays a green LED when the system is functioning properly. The EPU unit can be installed in areas visible to the operator in the equipment cabin without obstructing the LOS to objects outside of the cabin.

Proximity detection and alert systems are capable of four different alert scenarios. These scenarios describe the action of the technology when the construction ground worker is located a safe distance from a piece of construction equipment and when the ground worker is in a hazardous proximity situation. The hazardous proximity region around a piece of construction equipment is pre-defined and calibrated into the proximity detecting and alert devices. The following four scenarios can occur when using these systems on construction sites:

- | | |
|-----------------|--|
| True positive: | An alert is activated when a ground worker is in too close proximity with a piece of construction equipment. |
| False positive: | An alert is activated when a ground worker is located at a safe distance from a piece of construction equipment (also referred to as nuisance alarms). |
| True negative: | An alert is not activated when a ground worker is located at a safety distance from a piece of construction equipment. |
| False negative: | An alert is not activated when a ground worker is in too close proximity with a piece of construction equipment. |

Of the four alert scenarios, false negative scenarios are the most problematic case because the technology fails to alert the construction equipment operator of the hazardous

proximity situation. False positives (also called nuisance alarms) are also undesirable because frequent non-hazardous alerts can desensitize equipment operators to potential hazardous proximity situations. Both true positive and true negative alerts are the most desirable alert scenarios because they accurately identify the status of proximity situations on construction sites. Figure 25 presents a flowchart of the four possible alert scenarios for the designed experiments.

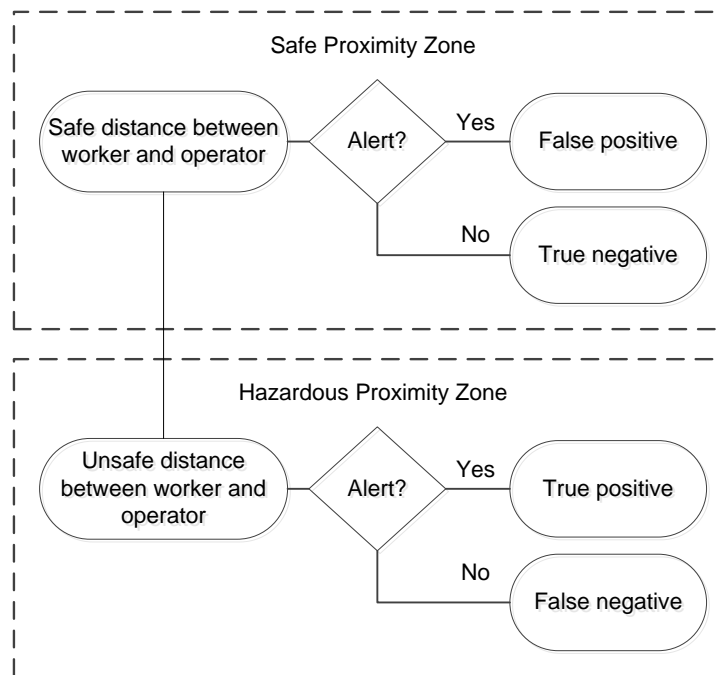

Figure 25: Alert scenarios flowchart for proximity detection and alert systems

6.5.2 Experiments Trials with Proximity Detection and Alert Devices

A proximity detection device prototype was used based on the safety needs of the construction industry. This system was evaluated in two different experimental settings, each evaluating the performance and capabilities of different aspects of the system.

For the first experimental trials, an EPU device was placed in a simulated construction environment to evaluate the effectiveness of the proximity detection system in the outdoor field conditions. The test bed for these trials was a clear, flat, asphalt paved surface with no obstructions. A commercially available Robotic Total Station (RTS) and traffic control devices were used to create the test bed. The RTS was positioned at the center of a 15.2 meter radius circle, and traffic control devices were placed at 36 equal distant locations around the circumference of the circle. The traffic control devices were positioned at 10 degree offsets around the circle. Figure 26 shows the created experimental test bed.



Figure 26: Coverage area experimental test bed

The center point of the circular test bed served as the location for the EPU's antenna component. The EPU was installed inside the equipment cabin (when applicable) in view and audible range of the operator. The antenna component of the EPU was mounted on top the operator's side of the equipment at the highest point. The PPU was attached to the hard hat of a ground worker. Figure 27 shows the mounting positions of both the EPU and PPU.



Figure 27: Mounting positions of personal protection device (left), installing antenna on equipment (right)

A test person wearing a hard hat equipped with a PPU approached each piece of construction equipment at a constant walking pace (2 meters per second) from 36 equal distance approach angles [207]. After the EPU device activated an alert, the worker stopped walking and measured the alert distance using a measuring wheel. This method was repeated twice for each approach angle and per piece of construction equipment. Three different personal detection devices with unique calibrated alert ranges were tested for each piece of equipment. This experimental procedure was performed using the following pieces of construction equipment: Grader, excavator, truck and trailer, pick-up truck, vibratory roller, dump truck, and forklift.

The total sample size for each piece of construction equipment was 216 measurements. A statistical analysis was performed on each subsample (every calibrated alert distance and piece of construction equipment) of measured alert distance. The data was also analyzed for false positive (also called nuisance alerts) and false negative readings. False negatives were defined as the worker striking the construction equipment before an alert was activated. Percentage values of activated alerts were also calculated for each piece of construction equipment tested.

Table 15 shows results of the data analysis for the proximity detection alert distances of the test person approaching a static asphalt paver. The calibrated range

named “Range 2” recorded the lowest standard deviation and range discrepancy when compared to the other calibrated devices tested on the asphalt paver. Numbers denoted with bold text in Table 15 were the most precise performers of the three different alert ranges. 99.5% of the 216 worker approaches activated an alert from the system. In two cases, the worker struck the asphalt paver without activating an alert which was recorded as a false negative reading.

Table 15: Statistical analysis of the alert measurements for the asphalt paver

	Range 1	Range 2	Range 3
Median	13.8 m	14.8 m	16.9 m
Minimum Distance	0.0 m	10.3 m	12.2 m
Maximum Distance	18.5 m	17.8 m	31.9 m
Range	18.5 m	7.5 m	19.7 m
Standard Deviation	2.7	1.7	3.4

The obtained data from each piece of construction equipment was used to create proximity alert range graphs. These graphs display the recorded distant measurement from the worker’s position to the EPU antenna at the time the alert is activated. Figure 28 shows the recorded alert distant measurements of the medium alert range personal protective device. The two lines represent the two different trials from each approach location with the medium alert range device. System coverage maps for other pieces of construction equipment tested are shown in Appendix C and results are shown in Table 16.

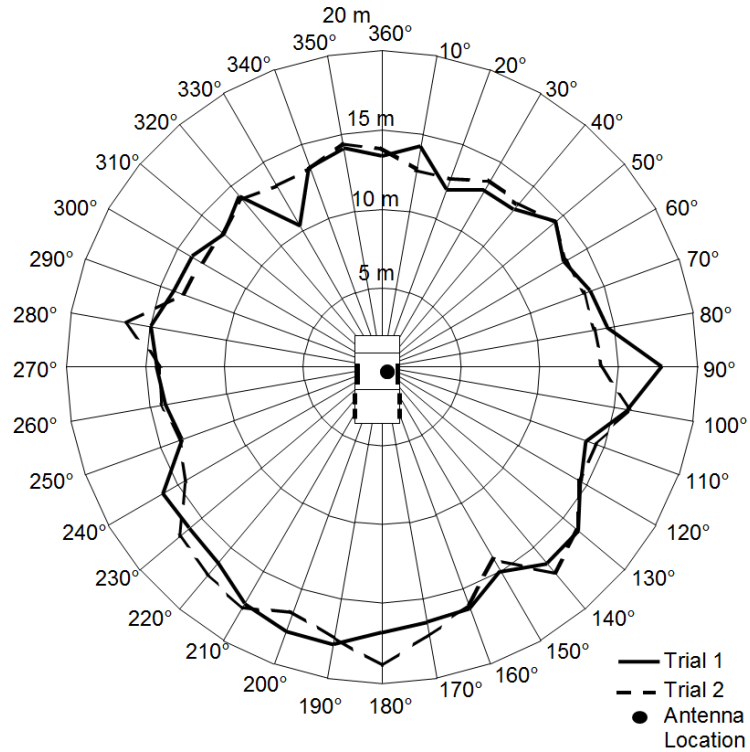

Figure 28: Active proximity warning zone for a specific alert range

In some cases, two EPU’s were required to create a coverage area that extended radially around each piece of equipment. Two EPU’s were used because the coverage area for one EPU was inadequate to provide alerts for each approach angle around the piece of construction equipment. Two antenna components of two different EPU devices were mounted on top of a forklift at the highest point on the equipment while the PPU was still attached to the worker-on-foot as was done in the previous experiment. These configurations can be viewed in Figure 29.



Figure 29: Mounting position of an EPU antenna on the forklift (left); a second EPU antenna mounting position on the forklift (right)

Similarly to the previous experiment, a ground worker wearing a hard hat equipped with a PPU approached the forklift at a constant walking pace from 36 equal distance approach angles. After the EPU device activated an alert, the worker stopped walking and measured the alert distance using a measuring wheel (see Figure 30). This method was repeated three times for each approach angle.



Figure 30: Measurement of the alert distance

The total sample size for the forklift tests was 108 measurements. A statistical analysis was performed on the measured alert distance. The average value of the three trials was used to perform the statistical analysis. Results of the data analysis for the proximity detection alert distances of workers approaching a static forklift are: Median = 9.7 meters, Range = 11.8 meters, and Standard Deviation = 3.2 meters. The system recorded no false negative readings meaning the alert was activated on every approach.

The obtained data from these trials was used to develop proximity alert range graphs. These graphs display the recorded distant measurement from the worker's position to the EPU antenna at the time the alert is activated. Figure 31 shows the recorded alert distant measurements of the proximity detection and alert system.

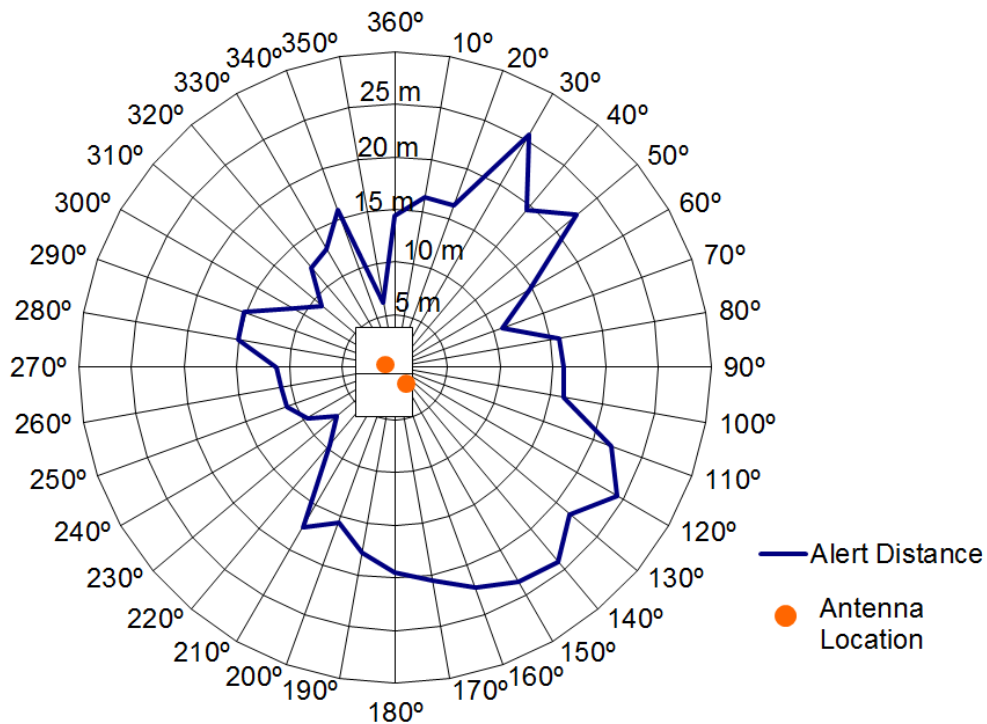

Figure 31: Forklift proximity warning zone for a calibrated alert range

The EPU devices were installed on several other pieces of heavy construction equipment. The same coverage area tests as previously described were used to evaluate the proximity detection and alert devices. Three different calibration ranges were tested on each piece of equipment. The calibration range with the highest percent coverage area was chosen as the calibration range for that piece of construction equipment. If all three calibration ranges provided total coverage around the piece of heavy construction equipment, the range with the smallest standard deviation of the three was selected. A statistical analysis for the selected calibration range for each piece of heavy equipment is shown in Table 16. False positive values were defined as the number of alert range distances greater than three times larger than the inner quartile range added to the upper quartile range value. False negative values were the number of times the test person contacted the heavy equipment before an alert was activated. Each calibration range has a sample size of 72 measurements (time constraints only allowed for two trials per each approach angle).

Table 16: Statistical analysis of proximity alert range for various pieces of construction equipment

Equipment	Average	Range	Standard Deviation	False Positives	False Negatives
Forklift	9.7 m	11.8 m	3.2	0	0
Wheel Loader	10.9 m	13.6 m	3.9	1	0
Grader	8.6 m	12.8 m	3.2	3	3
Asphalt Paver	14.7 m	7.5 m	1.7	0	1
Excavator	11.7 m	41.9 m	10.7	3	5
Truck and Trailer	7.2 m	13.0 m	9.4	0	2
Pick-Up Truck	8.4 m	22.5 m	4.8	8	0
Vibratory Roller	20.1 m	31.1 m	9.2	0	0
Mower	12.1 m	15.1 m	3.4	0	0
Dump Truck	16.0 m	22.2 m	6.0	2	0

A separate set of field experiments were conducted to test the effectiveness of the proximity detection devices on mobile equipment and static workers. These tests were completed on a flat, unobstructed paved surface similar to the previous field experiment. The EPU was installed in a pick-up truck with the antenna mounted on top of the truck's cab on the driver's side. A static ground worker equipped with a PPU was positioned next to the RTS, and was aligned on a straight path with the pick-up truck. Traffic control devices were spaced five and ten meters along the truck's straight trajectory towards the ground worker.

After maintaining a constant speed of 16 kilometers per hour (about 10 miles per hour), the truck driver stopped the vehicle after the alert triggered. As done in the previous field experiment, three different proximity detection devices with varied alert ranges were tested in this experiment. Each of the three different alert ranges was tested 32 times providing results within a 95 percent confidence interval [118]. Box plots of the three different ranges and 96 data points gathered from this experiment are shown on the right side of Figure 32. All trials resulted in true positive alerts. No false alerts or nuisance alerts occurred during any of the 96 trial runs.

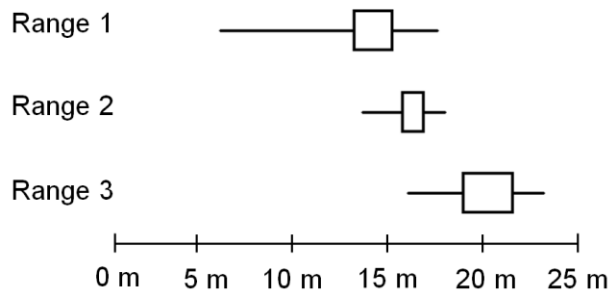

Figure 32: Box plot of proximity detection distance for each PPU

6.5.3 Data Recording

In addition to the location distance measured by the research team during all experimental trials of the presented testing method, the proximity detection and alert system has data recording and logging capabilities. During the previously described experiments, the system recorded the ground PPU device number, timestamp, and date of each proximity breach. A proximity breach included all instances in which a construction ground worker entered or exited the pre-calibrated hazardous proximity range around a piece of construction equipment. The column titled “Level” indicates the relative distance at which the system triggered an alert to the equipment operator. This value is specific to the proximity detection and alert system deployed for these experiments and it is used for calibrating specific system devices based on their relative distance and signal strength from other devices. The column titled “Status” denotes if the worker entered (“Trip”) or exited (“Clear”) the pre-defined proximity distance of a piece of construction equipment. The sample output of the data logged during the coverage area experiments of the asphalt paver can be viewed in Table 17.

Table 17: Sample output data of recorded proximity breaches

Tag ID	Level	Date	Time	Status
34	681	4/18/12	16:24:29	Trip
34	625	4/18/12	16:24:29	Clear
34	737	4/18/12	16:24:31	Trip
34	581	4/18/12	16:24:45	Clear
34	648	4/18/12	16:24:46	Trip
34	540	4/18/12	16:24:47	Clear
34	649	4/18/12	16:25:21	Trip
34	539	4/18/12	16:25:42	Clear
34	708	4/18/12	16:25:42	Trip
34	599	4/18/12	16:25:42	Clear
34	657	4/18/12	16:27:18	Trip
34	600	4/18/12	16:27:18	Clear
34	680	4/18/12	16:27:19	Trip
34	588	4/18/12	16:27:19	Clear
34	683	4/18/12	16:27:20	Trip
34	607	4/18/12	16:28:10	Clear
34	689	4/18/12	16:28:10	Trip

Information from this system was exported into a database for further analysis. Individuals involved with a large amount of proximity breaches when compared to co-workers were highlighted. From this point, construction safety managers can further explore details of the proximity breach by monitoring the individual on the project site and provide further safety training specific to hazardous proximity issues to select ground workers and equipment operators. Construction safety personnel can also use this tool to provide preventative safety training by reviewing past recorded data and informing ground workers and equipment operators of past hazardous proximity situations during certain construction activities.

The proximity breach range of the tested proximity detection and alert system are calibrated and function based on relative distances, or the distance from the PPU to the EPU relative to other detected devices. Proximity breach data for the both stages of the

construction field condition trials were recorded and analyzed. The relative distance at which the PPU device was detected can be viewed in Table 17 under the column heading “Level.” An alert was triggered (trip condition) or silenced (clear condition) by the EPU at these relative detected distances. Results indicate that physical features of construction equipment impact the correlation between the desired calibrated relative distance and the actual triggered alert relative distance. Table 18 shows an analysis of the calibrated alert distances and actual alert distances for the construction field condition trials using the normal distribution. For each of these trials, the PPU were calibrated as follows: Range 1: 640, Range 2: 580 and Range 3: 515. The software allows for calibrated relative alert distances between 0 and 1000.

Table 18: Analysis of recorded relative distances or level for alerts (unitless) of the field trials

	Average alert level	Range of alert level	Standard deviation of alert level
Range 1	590.1	317	32.5
Range 2	575.7	118	19.8
Range 3	546.6	398	34.2

6.5.4 Validation

To better understand the impact of construction equipment components on the project signal from proximity detection and alert systems, the system was deployed in a clear, flat, unobstructed environment. The EPU antenna was mounted on a wooden tripod and the PPU was mounted to a test person’s hardhat as described in the previous experiment. Experimental trials were conducted similar to the previous experiment in which the test person approached the EPU tripod twice from 36 equal distant approach

angles at a constant walking speed (2 meters per second). The proximity detection and alert system was calibrated to “Range 2” as discussed in the previous experimental trials. The median recorded alert distance was 14.9 meters, the range was 1.8 meters, and the standard deviation was 0.47. For this trial, no false positive or false negative alerts were recorded.

6.5.5 Limitations, Future Work, and Application Areas

The objective was to evaluate the reliability and effectiveness of a proximity detection and alert system used in the construction environment. After completing the experiments, the trials revealed limitations to the proximity detection and alert system. Many parameters and potential influences on the system should be evaluated through future experimentation. Future studies should include the following:

- Impact of temperature, humidity, precipitation and other ambient influences on warnings and alerts, and in particular on use of batteries on PPU's,
- Location and mounting positions of the EPU's and PPU's,
- Specific configuration and placement of PPU - device must be minimally intrusive on the worker and must perform reliably to active alerts.
- Reaction of ground workers and equipment operators to implementing the devices,
- Calibration of specialized alert distances for individual pieces of construction equipment including operator and ground worker reaction time, operator brake

distances, ground surface preparation, weather conditions and object mitigation strategy,

- Record and analyze “near-miss” data to improve education construction workers on proximity issues,
- Identify in real-time and record the position and trajectory of the hazard,
- Analysis of calibrated alert distances and actual alert distances on various pieces of construction equipment in different environmental settings including obstacles blocking the line-of-sight between the PPU and EPU,
- Collect and analyze “nuisance alerts” to evaluate reliability of system,
- Create an implementation strategy for proximity detection systems in construction, and
- Extended construction field trials with the proximity detection devices.
- A return on investment of proximity detection and alert devices implemented onto construction sites. A case study with one company and five years of worker accident data and the previously described RF proximity detection and alert system revealed a return on investment value of 4.5.

Illnesses, injuries and fatalities resulting from hazardous proximity issues can become very expensive after summing medical costs, insurance costs, productivity decrease resulting from time lost, and possible litigation costs. Some of these costs could potentially be avoided by implementing emerging safety technologies such as real-time proximity detection and alert systems. This safety technology can improve safety on

construction sites by giving construction equipment operators a warning during a hazardous proximity situation.

6.6 Conclusions

Current safety practices for proximity issues in construction have proven inadequate as demonstrated by the number of fatalities, accidents, and illnesses resulted from proximity issues. The ultimate goal of the construction industry must be to achieve zero accidents and injuries for all construction sites. The purpose was to evaluate the capabilities of a proximity detection and alert system to function in the construction environment both reliability and effectively when construction resources (e.g. workers and equipment) are in too close proximity. Results obtained from the review and experiments suggest that the proximity sensing and alert systems can be effective in certain situations and can potentially improve equipment-worker safety in construction.

The proximity detection and alert system demonstrated its ability to perform by detecting the presence of hazardous proximity situations on construction sites. The designed experiments tested different pieces of construction equipment including a grader, excavator, truck and trailer, pick-up truck, vibratory roller, forklift, dump truck, and asphalt paver. In nearly all trials, the proximity detection system was able to detect and activate an alert when construction resources were in too close proximity to each other. In one instance, the radio frequency signal was blocked by a metal exhaust pipe which indicates multiple antennas should be installed on a piece of construction equipment to cover all signal blind spots. The audible alerts were to a sufficient volume

to be heard over back-up alarms and other general and loud construction noise. The equipment operator was also able to see the visual alert provided by the EPU.

Although the field trials with the proximity detection and alert system were deemed successful, the experiments revealed other parameters that could potentially have an influence on the system, specifically the signal propagation and orientation of PPU. When the LOS between the PPU and EPU was obstructed by a component of the construction equipment, the devices were sometimes unable to communicate and detect the presence of the PPU. The overall system alert distance should eventually be optimized such that a ground worker and equipment operator are only alerted when a hazardous condition exists. For example, the proximity sensing technology could be calibrated such that an alert only occurs when a ground worker enters an equipment operator blind spot.

Some research has investigated the use of autonomous construction equipment control that allows for operator-less construction equipment [116][117]. The work presented allows for immediate retrofit on construction equipment where autonomous construction equipment operation requires further investigation of how construction equipment can interact autonomously with or without the presence of ground workers on construction sites.

Human physiology and worker response to alerts also would be required for further investigation related to implementing proximity detection and alert systems into the construction site environment. Specifically, researchers should specifically identify optimized hazard alerting methods for construction workers. By identifying the most effective alert methods, technology can be equipped with these alert devices and further

enhance safety for construction site personnel. These barriers along with others require further investigation to better evaluate the effectiveness of implementing proximity detection and alert devices in the construction environment.

CHAPTER 7

POSITION AND ORIENTATION OF (SEMI-) PASSIVE RFID PPU'S

Hazardous proximity conditions and situations exist when heavy construction equipment is operating in close proximity to ground workers. The objective of this research described in this chapter is to evaluate the capabilities and reliability of (semi-) passive RFID technology when used for proximity sensing in the construction environment. Experiments emulating typical movements of ground workers are designed and executed. Various positions and orientations of the designed (semi-) passive RFID-based PPU were evaluated based on typical ground worker movements during construction tasks. Results indicate that both position and orientation of the PPU impact the reliability of the system's ability to activate alerts during hazardous proximity situations. The overall purpose of this research described in this chapter is to generate scientific data and knowledge of proximity detection and alert system for eventual implementation of these systems on construction sites. Limitations of RFID technology for proximity detection and alert technologies were identified and discussed in this section.

7.1 Introduction

The dynamic nature of each construction site often requires multiple construction resources including personnel and heavy equipment to operate within close proximity to one another. Chapter 6 identified RFID technology as a potential candidate for providing real-time alerts to construction site personnel when construction resources (ground

workers and construction equipment) were in too close proximity to one another. Benefits of RFID technology have been leveraged in several U.S. industrial sectors including the construction industry. However, the harsh working environment that is characteristic of construction projects can present barriers for the functionality of RFID technology. For this research, experimental trials designed to simulate the movement required of ground workers on construction sites were used to evaluate the effectiveness and reliability of RFID technology functioning in the construction environment. Results describe realized limitations of RFID technology for proximity detection and alert systems when deployed in the construction environment.

7.2 Background

Construction sites often have limited workspace requiring construction resources to function in close proximity to one another. As construction injury and fatality statistics show, these work environment conditions result in dangerous proximity situations for ground workers. Proximity issues remain a key problem in the safety of workers on construction projects.

RFID technology (both passive and active systems) has been tested for many applications both in construction as well as other industries. Construction utilization of RFID technology include construction tool tracking [208], personnel tracking [185], material tracking [162], and construction site safety applications [186]. Basic feasibility tests for RFID technology were completed for proximity sensing applications in the mining environment which has similar conditions to typical construction sites [205].

A lack of scientific evaluation data exists for RFID technology used for safety applications on construction sites. Specifically, combinations of mounting positions and orientations for components of proximity detection and alert systems are required. This evaluation should be accomplished through current or newly developed experimental methods, case studies, and data analysis.

7.3 Objective and Scope

The objective is to evaluate the reliability of various positions and orientations of passive RFID technology as a potential detection component in PPU devices. As part of a proximity detection and alert system, its function is activating an alert in real-time to construction personnel when they get in too close proximity to an antenna deployed on a piece of construction equipment. The different positions and orientations of passive RFID for PPU were tested using simulated ground worker movements towards commercially-available components of a passive RFID tag-antenna system.

7.4 Research Methodology and Results

All experimental trials were designed to generate evaluation data detailing the effectiveness of various passive RFID tag positions and orientations for a PPU within a proximity detection and alert system. The PPU was mounted at various locations and orientations on Personal Protection Equipment (PPE).

7.4.1 Technology Evaluated

The real-time proximity detection and alert system evaluated during these experiments utilizes active UHF technology to detect proximity breaches of construction equipment and ground workers. If two or more construction resources are in too close proximity, the sensing technology will activate an alarm to warn construction personnel through EPU's and PPU's. The EPU is equipped with a reader, alert mechanism, and single directional antenna that transmits and receives PPU information during a proximity breach such as a timestamp, PPU identification number and magnitude of the reflected radio frequency signal. The PPU is equipped with an alert mechanism, chip, and battery. This device can be installed on a worker's hard hat or safety vest. The PPU surface area dimensions are 5.5 centimeters by 8.5 centimeters and the thickness is minimal. The PPU is flexible and can be attached to solid objects. Both the EPU and PPU device can be viewed in Figure 33.

Power is supplied to the EPU component of the proximity detection device through the existing battery on the piece of equipment. The PPU intercepts and reflects back a broadcasted signal from the EPU which instantaneously activates an alert in real-time when devices are in close proximity to one another. The audible alert triggered by the EPU creates ample noise so that the equipment operator is able to hear the alert above sounds typically to construction sites. Figure 33 shows the EPU installed on a tripod (left) and PPU mounted on a worker's safety vest (right).



Figure 33: Proximity detection and alert system: EPU (left) and PPU (right)

The signal broadcasted by the EPU is projected in a radial manner and loses strength as the PPU moves farther from the EPU location. The signal strength emitted by the EPU remained consistent throughout the experimental trials. The EPU's antenna was installed in locations where the LOS between the EPU and PPU was not obstructed. The proximity detection and alert system evaluated is also able to log data concerning PPU proximity breaches. The data logging function records the PPU and EPU identification number as well as the timestamp and Received Signal Strength Indication (RSSI) for each proximity breach.

8.4.2 Experiments and Results

The objective of the designed and executed experiments was to assess the performance of a proximity detection and alert system using RFID technology when the PPU was positioned and oriented at multiple angles. All experimental trials were performed in an outdoor environment with mostly clear and mostly sunny weather conditions with a temperature of 75 degrees Fahrenheit. A clear and flat grass ground surface with no obstructions was used for a test bed for these trials. A RTS was used to position markers along a straight path perpendicular to the face plane of the EPU antenna. As displayed in Figure 34, the markers (centerline) were placed at three meter intervals to

outline the walking path of a test person towards the antenna. In later experiments a test person approached the antenna from angles within its field-of-signal (FOS), which was approximately 30 degrees to each side of the centerline.



Figure 34: PPU position and orientation test bed

The EPU's antenna component was mounted on a tripod with the face plane perpendicular to the ground surface. for the experimental trials. The EPU antenna is capable of reading 60 degrees in direction parallel to the antenna's face plane. The antenna's centriod was positionned 1.15 meters vertically from the ground surface. This vertical distance represented the average elevation between the top of test person's hard hat and center of the test person's safety vest. Although the mounting postion of the antenna can vary on equipment, testing with other heights was not performed.

The test person equipped with a semi-passive RFID tag for the PPU began walking outside of the proximity range (approximately 40 meters from the EPU) along the path outlined by the markers. The test person maintained a constant walking pace of approximately 2 meters per second until an alert was activated [205]. The test person stopped and measured the distance from the stopped position to the EPU's antenna position. Each combination of tag position and orientation was conducted ten times.

A total of eight PPU position and orientation combinations were tested. For the purposes of this research, the term “position” refers to the location of the face plane of the device in relation to the ground surface. For example, the horizontal position is achieved by the face plane of the device being parallel to the ground surface and perpendicular to the EPU antenna face. Likewise, a vertically positioned tag has the face plane perpendicular to the ground surface and parallel to the EPU antenna face. Figure 35 shows both of these tag positions where the device is mounted on a hard hat in the vertical position (left) and horizontal position (right).



Figure 35 PPU mounted on a hard hat in the vertical position (left) and the horizontal position (right)

Four PPU orientations were used in combinations with the previously described PPU positions. The orientations were based on the location of the PPU in relation to the EPU antenna or the sky. Each of the four PPU orientations were assigned a number (1, 2, 3, or 4) depending on the location of the PPU. Figure 39 presents a diagram to show how each numbered orientation was related to the EPU’s antenna or sky and ground reference. Three different of the same type of tag were evaluated at the eight combinations of position and orientation.

Table 19 gives results of the statistical analysis of the alert distance results from the PPU positioned horizontally and mounted on top of the test person’s hard hat. The value of the mean, minimum alert distance, range (which is the statistical maximum value

subtracted from the statistical minimum value), and standard deviation of the alert distances were calculated from the ten trials of each PPU. In an optimized situation, the tolerance of distance alert range values should be minimal indicating high reliability for the proximity detection and alert system. Values of the highest mean, and the lowest range and standard deviation (bolded in Table 19). Other experiments with the PPU attached to the worker's hard hat are shown in Appendix D. Table 19 also demonstrates the significant difference of the mean and minimum value when changing the orientation of the PPU (a worker during 90 degrees from the original position facing the EPU antenna).

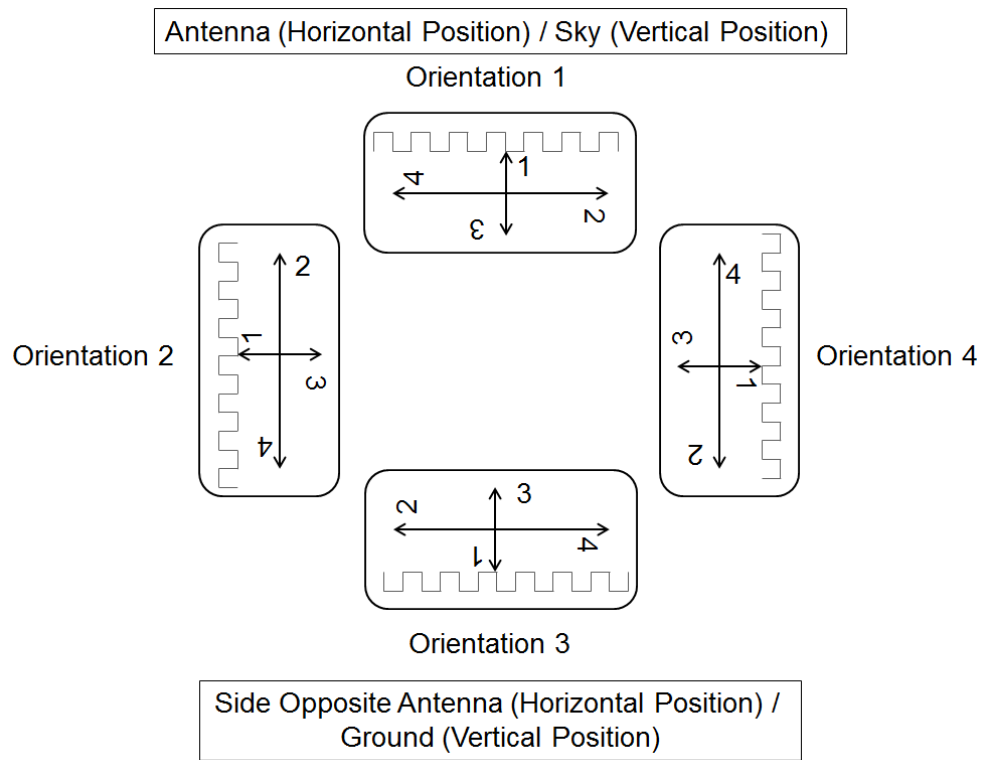

Figure 36: PPU orientation in relation to the EPU antenna and ground surface

Table 19: Semi-passive PPU orientations mounted on top of a hard hat

		PPU 1	PPU 2	PPU 3
Orientation 1	Mean:	37.7 m	38.8 m	37.8 m
	Min.:	36.8 m	38.0 m	37.0 m
	Range:	1.3 m	1.5 m	1.3 m
	Std. Dev.:	0.6	0.8	0.7
Orientation 2	Mean:	21.9 m	10.8 m	11.3 m
	Min.:	19.0 m	10.0 m	9.5 m
	Range:	5.8 m	1.5 m	3.0 m
	Std. Dev.:	2.9	0.8	1.6
Orientation 3	Mean:	34.1 m	12.7 m	37.4 m
	Min.:	32.0 m	12.0 m	36.3 m
	Range:	4.3 m	1.5 m	2.8 m
	Std. Dev.:	2.1	0.8	1.4
Orientation 4	Mean:	13.5 m	12.3 m	12.6 m
	Min.:	9.8 m	11.0 m	11.5 m
	Range:	5.5 m	2.8 m	5.3 m
	Std. Dev.:	3.0	1.4	2.7

Orientation 1 or PPU 1 and 3 recorded the highest mean value, lowest range, and the lowest value for the standard deviation. Data was collected and analyzed for following eight individual configurations of vertical position: (1) side of hard hat, (2) front of hard hat, (3) back of hard hat, (4) front pocket of safety vest, (5) back pocket of safety vest, and (6) side of shoulder; and horizontally positioned, (7) top of worker hard hat, and (8) top of shoulder.

Values of the highest mean, highest minimum, lowest range, and lowest standard deviation values of each semi-passive RFID tag tested position and orientation configuration was identified from the four configurations tested on the hard hat (see Table 20). A similar table was created to summarize the results from experimental trials completed using the safety vest. Results of these tests are shown in Appendix D. In Table

20, the top performers have bolded values, and the top performing orientations of each PPU is noted in parenthesis to the right of each value.

Table 20: PPU orientation summary on the hard hat

		PPU 1	PPU 2	PPU 3
Top	Mean:	37.7 m (1)	38.8 m (1)	37.8 m (1)
	Min.:	11.5 m (4)	10.0 m (2)	12.5 m (2)
	Range:	1.3 m (1)	1.5 m (1)	1.3 m (1)
	Std. Dev.:	0.6 (1)	0.8 (1)	0.7 (1)
Side	Mean:	8.9 m (1)	5.7 m (1)	8.6 m (3)
	Min.:	1.5 m (3)	4.3 m (2)	4.5 m (2)
	Range:	1.0 m (1)	1.5 m (2)	5.3 m (2)
	Std. Dev.:	0.5 (1)	0.3 (3)	0.8 (2)
Front	Mean:	36.5 m (1)	38.2 m (1)	38.4 m (1)
	Min.:	4.5 m (4)	5.0 m (4)	12.5 m (4)
	Range:	3.0 m (1,2)	0.5 m (3)	1.5 m (2)
	Std. Dev.:	1.5 (1)	0.3 (3)	0.8 (2)
Back	Mean:	10.8 m (2)	28.8 m (3)	26.8 m (3)
	Min.:	2.0 m (4)	3.0 m (4)	4.0 m (2)
	Range:	1.3 m (2)	6.3 m (3)	7.8 m (3)
	Std. Dev.:	0.7 (2)	0.3 (4)	1.0 (1)

Orientation 1 mounted on top of the hard hat recorded the highest mean value when compared to the other tested configurations. When mounted on the side and front of the hard hat, orientation 3 experienced the lowest value of standard deviation. When mounted on top of the hard hat, the tag had the highest number of top performing orientations when compared to the other configurations tested. The front mounting position had similar values to mounting the tag on top of the hard hat. The largest mean value was recorded when placing the tag in the front pocket of the vest.

Further data analysis showed that tag orientations 1 and 3 on the top and front of the hard hat were the best performers when compared to the other configurations

evaluated. When mounted on the safety vest, orientations 1 and 3 had the highest alert distance. Other trials of mounting the PPU on the shoulder and back of the safety vest resulted in false negative alerts meaning the test person was able to reach the EPU antenna before an alert was activated. Polarization effects were experienced when the PPU was positioned vertically in orientation 2 and 4, locations that could prove beneficial for other worker movements such as bending. In summary, tag position and orientation of (semi-) passive RFID tags played a key role in successfully detecting the tag by the reader. The results demonstrate that deploying a single (or multiple) tag(s) may result in false negative alerts.

More testing is required for these tag locations such as a test person approaching the EPU antenna while positioning his/her body such that their back is facing the EPU antenna. Multiple tags can also be mounted on the worker hard hat and safety vest to better cover all approach angles. Further research is also required to evaluate potential external influences on the system such as the EPU antenna mounting location, impact of other construction resources, and various calibrated alert ranges. Data that is recorded and analyzed from these systems can improve safety site layout and assist in the development of new safety concepts for worker safety training.

As mentioned previously, three PPU tags were used during the experimental trials. Each PPU was calibrated to the same alert distance. A separate set of trials were performed to capture discrepancies between the three tested PPU tags. The same experimental test bed was used, however the PPU tags were held by the test person in position 1. The test person walked at the same speed in the same direction (in a straight

path towards the EPU antenna) and recorded the distance once an alert was activated. Table 21 shows a statistical analysis performed on these trials.

Table 21: Results of PPU trials

	PPU 1	PPU 2	PPU 3
Median	38.3 m	34.2 m	36.1 m
Minimum	34.5 m	33.6 m	32.1 m
Range	2.0 m	1.5 m	1.8 m
Standard Deviation	0.4	0.2	0.7

7.5 Conclusions

Collisions between ground workers and construction equipment or objects is one of the leading causes of fatalities in construction. The purpose of this research was to evaluate the effectiveness and capabilities of various configurations of (semi-) passive RFID tags used for electronic personal protective device positions and orientations. Results from the review and experiments indicate that proximity detection and alert systems that systems relying on passive RFID position and orientation impact the effectiveness of these systems. The major shortcoming that was identified through the field trials is that commercially existing (semi-) passive RFID tags, based on its two-dimensional antenna design, may not be suitable for reliable implementation in PPU safety systems unless all potential worker-to-equipment poses and positions can be covered. Although existing construction research on active and passive RFID technology has shown mostly the benefits of RFID technology, further study is necessary, in particular on 3D (semi-) passive RFID tags that avoid the previously described limitations of 2D RFID antenna tag designs.

CHAPTER 8

TEST METHOD FOR PROXIMITY SENSING TECHNOLOGY

This chapter presents a testing method for proximity detection and alert systems deployed on construction sites. Several scenarios typical of construction equipment and ground worker movement on construction sites were designed and tested. Specifically, the reliability and effectiveness of proximity detection and alert systems to provide alerts to construction site personnel during hazardous proximity situations were assessed. Devices were installed on pieces of construction equipment in an outdoor environment to evaluate the created test method for proximity detection and alert systems.

8.1 Introduction

Construction environments are typically comprised of multiple resources (personnel, equipment, and materials) that perform dynamic activities in a specific space. This often requires construction resources, such as ground workers and heavy equipment, to operate at close proximity to each other creating potential hazardous proximity situations. The risk of injuries and fatalities increases as contact collisions between ground workers and heavy construction equipment occur.

Minimal information and data exists on how existing safety technologies can be implemented into construction environments to create an additional layer of safety protection for ground workers. Thorough evaluation of emerging safety technologies through experimentation simulating conditions of a typical construction environment is required. Evaluation data through an established test method can show the reliability and

effectiveness of these technologies, including proximity detection and alert systems. This test method can be used by construction companies to evaluate the capabilities of proximity detection and alert systems to meet specific needs of their construction sites and personnel.

8.2 Background

A multitude of movements of construction resources coupled with the densely populated nature of construction sites can account for safety concerns resulting from proximity issues [68]. As previously discussed, hazardous proximity situations between ground workers and construction equipment are present on construction sites. The following review covers proximity detection and alert systems, magnetic field sensing, and testing methods of proximity detection and alert systems.

8.2.1 Proximity Detection and Alert Systems

Various technologies and system combinations are thought to be capable of alerting construction personnel in real-time [209]. Initial testing and evaluation has occurred for proximity detection systems in other industries such as underground mining [163], the railroad industry [210], and manufacturing [211]. Safety technologies can provide workers with a “second chance” by creating an additional layer of protection for ground workers on construction sites [68]. Proximity detection and alert systems were reviewed for their capabilities to function in the mining [192] industry which shares characteristics with construction site environments [130].

Several parameters were used to assess each system including detection area, alert method, precision, size, weight, calibration functionality, power source, ability to identify people from objects, and others. Benefits and limitations of each technology were identified. For example, systems utilizing radio frequency technology can be impacted by direct contact with metallic objects [132][208] and experiences multipath or “crosstalk” that limit the system’s ability to distinguish individual worker proximity breaches [212][213]. Some of the evaluated systems were incapable of identifying people versus other objects [154][163][214]. These benefits and limitations were used to identify a reliable technology capable of detecting and alerting workers during hazardous proximity situations [154]. Results from the review indicate that proximity detection and alert systems utilizing magnetic field technology can be reliable in the construction environment.

8.2.2 Magnetic Field Sensors

Magnetic fields are created from motion of electric charges and are often accompanied by electric field waves creating electromagnetic fields. The strength of these electric charges (or current) is strongest close to the generating source and diminishes as the distance from the source increases. These currents are present in overhead high voltage transmission lines, near household appliances, and industrial settings such as near induction furnaces. Minimal experimental evidence exists that magnetic fields can affect human physiology and behavior in strengths levels typically found in public areas and specific to the construction environment [215].

Magnetic sensors have historically been used primarily for navigation, but other needs have evolved as the technology has improved in compatibility with other electronic systems, sensitivity, and smaller size [216][217]. While conventional sensors can directly measure parameters such as temperature, pressure, strain, and light, magnetic sensors indirectly measure direction, presence, rotation, current, and angle, through indirect changes or disturbances in the generated magnetic field. For proximity detection applications, magnetic fields are affixed from a permanent magnetic, electromagnetic, or current source [218]. A biasing magnet affixed to a Giant Magnetoresistive (GMR) sensor is most often used to detect the presence of a ferromagnetic object. GMR's allow for long magnetic field dependent changes in resistance in thin-film ferromagnetic and non-magnetic metallic multilayers [216]. The biasing magnet is mounted on top of the sensor so the magnetic axis is perpendicular to the sensitive axis of the sensor.

A shell-based model of the magnetic flux density distribution was created to lay the foundation for identifying a worker's location during hazardous proximity situations [219][220][221]. A Gauss meter measured three magnetic field shells in which the bottom half of the flux is an approximation based on the created shell measuring model. The shell range is dependent on the density of the generated magnetic flux [219].

Several experiments have been conducted to better understand the correlation between signal strength and location of wireless communicating technological systems. One study found no direct relationship between the signal strength of RF and the location of the receiver device [219]. Figure 37 shows the experimental set-up and results of this test.

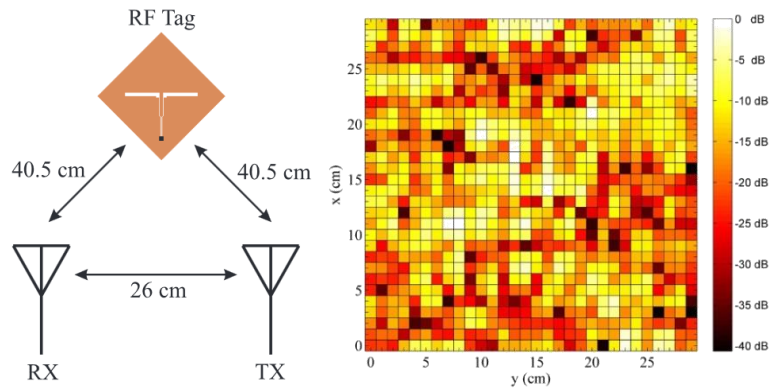

Figure 37: Test method (left) for measuring RF signal strength and results (right)

[222]

Results from this study further presented barriers associated with implementing RF technology for proximity detection and alert systems in the construction environment. Other technologies, such as magnetic field systems, showed a stronger connection between signal strength and location of the receiver device. A similar study showed that signal strength of magnetic field proximity detection and alert systems followed the magnetic shells propagated by the EPU [216]. This study indicated that magnetic field proximity detection and alert systems could be a more viable candidate for potential deployment in the construction environment than RF systems. Figure 38 shows the magnetic shells generated from a magnetic field proximity detection and alert system and results of the signal strength measurement of the magnetic field proximity detection and alert system [216].

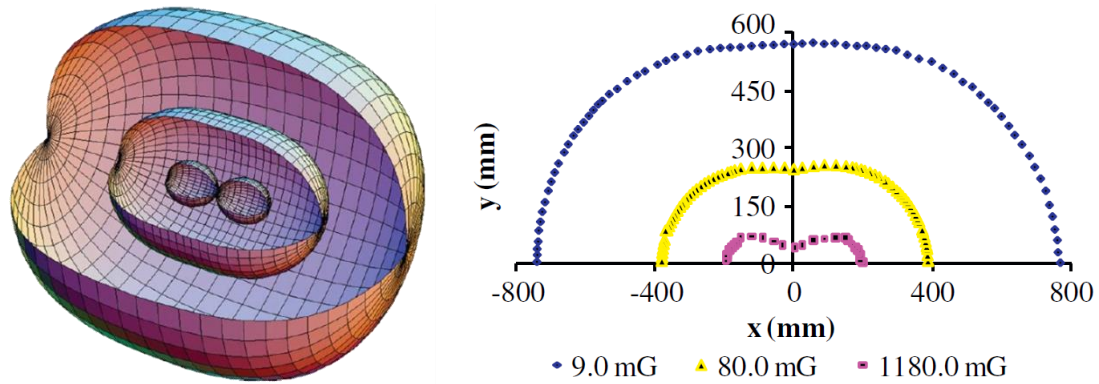

Figure 38: Magnetic field shells projected from the EPU (left), and signal strength measurements of a magnetic field proximity detection and alert system (right) [216]

8.2.3 Testing Methods of Proximity Detection and Alert Systems

Past research has developed preliminary testing methods to evaluate various proximity detection and alert systems. Ground markings have been placed and manually measured to outline the alert detection area of a system in an outdoor copper mining environment [163]. Other testing methods integrated typical surface mining site obstructions (dirt berm) to conduct field trials on a radar proximity detection and alert system [206].

8.3 Objective and Scope

The primary objective is to create a testing method for evaluating the effectiveness and reliability of proximity detection and alert technologies in the construction environment. A secondary objective is to evaluate the testing method by subjecting a magnetic field proximity detection and alert system to each component of the prescribed testing method. The testing method assesses the magnetic field proximity detection and alert system's ability to detect and alert construction site personnel when

hazardous proximity situations exist. The scope includes proximity issues between construction equipment and ground workers on level surfaces in outdoor construction sites.

8.4 Testing Method for Proximity Detection and Alert Systems

Each set of experimental trials of the testing method were designed to evaluate the reliability and effectiveness of a proximity detection and alert system when deployed in the construction environment on ground workers and heavy equipment. Each of the four experimental trials simulated functional characteristics of a construction site including combinations of static and mobile ground workers and heavy equipment. All trials were performed in an outdoor environment with mostly clear weather conditions and a temperature of approximately 85 degrees Fahrenheit. A clear and flat ground surface with no obstructions was used as a test bed for all trials. The testing method to evaluate proximity detection and alert systems, experimental methodology, and results of the magnetic field sensing system are presented. The presented methodology and examples should be followed when evaluating proximity detection and alert system include test bed set-ups, data collection methods, and data analysis.

8.4.1 Magnetic Field Proximity Detection and Alert System

Based on previous research results including cited benefits and limitations [130][163][173], proximity detection and alert systems using low frequency magnetic field technology (approximately 73 kHz) can function on construction sites. These systems provide a wireless, reliable, and rugged technology that is capable of functioning

in the harsh outdoor construction environmental setting. Magnetic field proximity detection and alert systems are thought to be capable of providing alerts in real-time for equipment operators and ground workers during hazardous proximity situations, create a tool for mitigating risk, monitor with minimal distractions (e.g. alerts that occur during non-hazardous conditions also called nuisance alerts), and create an additional protection layer for ground workers. The system requires a power source generated from the piece of construction equipment and devices must be installed on ground workers and construction equipment.

The EPU of the proximity detection and alert system contains a magnetic antenna connected to a central hub unit capable of calibrating the proximity detection area. The prototype dimensions of the EPU antenna are: 25 centimeters in length, 19 centimeters in width, and 10 centimeters in thickness and will be smaller in size after further modification. The EPU antenna generating the magnetic field contains a ferrite core material powered by the system to generate a magnetic flux. Unlike other omnidirectional antennas that broadcast signals (such as RF antennas), magnetic shells generated from the source that create the magnetic field resembling a 3D oval shape rather than circular due to the magnet's polarity [219]. For the proposed experiments, the EPU antenna was placed on top of a wheel loader cabin as seen in Figure 39. The antenna was positioned 3.5 meters vertically from the ground surface and 0.6 meter (horizontally) directly behind the operator's seated position.

The PPU of the proximity detection and alert system can be installed on the PPE such as a hard hat or safety vest of a construction worker. The receiver unit of the PPU is approximately 6 centimeters in width, 9.5 centimeters in length, and 2.5 centimeters in

thickness. This device uses a standard size lithium-thionyl chloride battery for power, and was held approximately 1.5 meters vertically from the ground surface by the test person for the designed experiments. Both the EPU and PPU can be viewed in Figure 39. For all experimental trials, the EPU antenna was attached to the top exterior of a wheel loader operator cabin.



Figure 39: Mounting position of EPU (left), PPU held by test person (right)

The EPU antenna projects a magnetic field which is intercepted by surrounding PPU's that breach into the pre-calibrated field. Various strengths of the generated magnetic field emitted by the EPU antenna allow for various alert distances. The system is capable of providing four separate alert distances in one setting. Each of the four separate alert distance settings can be calibrated to the desired physical horizontal distance between the construction equipment and ground worker. The alert distances allow for variations in alert distances depending on the location of the ground worker inside the magnetic field. The PPU alert zone is farthest from the EPU antenna mounted on the piece of construction equipment, and the stop zone is closest to the construction equipment.

As the ground worker nears the piece of construction equipment and penetrates the generated magnetic shells from the EPU antenna, the alert method intensifies in

frequency of visual (flashing LED lights) and audible (alert beeping sounds) to the equipment operator. These alert distances can be calibrated for specific pieces of construction equipment and site conditions. The ground worker and operator alert method is presented in Table 22 for each calibrated alert zone. The alert distance was calibrated for the longest distance for the deployed EPU antenna, and the calibrated alert distance remained constant for all experimental trials.

Table 22: System alert zones and methods

Zone	Ground Worker	Operator
PPU alert	1 audible beep	No alert
Hazard zone	1 audible beep	1 audible beep to operator with visual LED flashes
Slow zone	1 audible beep	2 audible beeps with visual LED flashes
Stop zone	1 audible beep	3 audible beeps with visual LED flashes

The following sections prescribe a method for evaluating the effectiveness and reliability of a proximity detection and alert system when deployed in the construction environment. Five different experimental trials are designed to emulate typical construction interactions between construction equipment and ground workers. To test proximity detection and alert systems for future use in the construction environment, each of the experimental trials should be performed as prescribed in the following descriptions. The following experimental trials make up the testing method for proximity detection and alert systems:

- 1) Technology selection
- 2) Coverage area
- 3) Mobile equipment with static worker
- 4) Obstructed PPU
- 5) Mobile equipment and mobile worker

8.4.2 Coverage Area

The coverage area experimental trials were the first section of the testing method for proximity detection and alert systems. This tested evaluated the reliability of the proximity detection system to provide an alert to a mobile test person while the wheel loader remained static. The experimental test bed was outlined by placing ground markers at 36 equal distant locations (10 degree offsets) around the circumference of a 15.2 meters (50 feet) radius circle on an unobstructed, flat surface. These ground markers designate the start of the angles used by the test person to approach the EPU antenna. The center point of the circular test bed served as the horizontal EPU antenna location which was installed on a wheel loader. The EPU antenna was positioned 3.5 meters vertically from the circle's center point. The PPU was held at shoulder height (approximately 1.5 meters) near the test person's left shoulder. The test bed is shown in Figure 40.



Figure 40: Test bed for static equipment and mobile ground worker

The test person equipped with the PPU approached the wheel loader at a constant walking pace (approximately 2 meters per second) from 36 equal distant approach angles. When the proximity detection and alert system detected the worker's breach into the hazardous proximity area, an alert was activated and the test person stopped walking and measured the horizontal alert distance. The alert distance was measured from the test person's stopped position to the EPU antenna. Three trials were tested for all angles, and 32 trials were completed for each 30 degree section (0°, 30°, 60°, ... , 300°, 330°) so that results at these locations were within a 95 percent confidence interval (Fowler 2009). This procedure was completed for both the PPU and hazard alert zones (also called the EPU alert zones).

A statistical analysis was performed on each approach angle of the test person. The data was also analyzed for false positive readings and nuisance alerts. The following circumstances were used for each of the following:

False positive alert: Instances in which the test person strikes the construction equipment before an alert is activated

Nuisance alert: Alert distance measurements three times larger than the upper quartile value for each specific approach angle

No nuisance alerts or false positive alerts were recorded during the experimental trials. Table 23 shows the data analysis results of the 30 degree intervals for the PPU alert distance measurements. Because the proximity alert area for magnetic fields mimics an oval shape outline, the range, standard deviation, and minimum values are used as a

comparison metric for different approach angles rather than minimum or maximum values. Values in bold text represent the lowest range and lowest standard deviation. The values in italic text are the highest range and highest standard deviation. After identifying increased range and standard deviation values, further investigation can improve the precision of the calibrated alert zone. These statistics should be recorded and analyzed when performing the coverage area experimental trials.

Table 23: Statistical analysis of horizontal alert distance measurements

Angle	Median Alert Distance		Range		Standard Deviation	
	EPU	PPU	EPU	PPU	EPU	PPU
360°	7.83 m	12.01 m	1.28 m	<i>3.29 m</i>	0.23	<i>0.72</i>
30°	7.97 m	11.84 m	1.52 m	1.74 m	0.32	0.38
60°	6.52 m	10.24 m	0.91 m	1.34 m	<i>0.60</i>	0.34
90°	7.31 m	11.93 m	1.16 m	1.25 m	0.34	0.61
120°	12.11 m	13.66 m	<i>2.26 m</i>	1.89 m	0.48	0.36
150°	6.55 m	13.59 m	1.80 m	2.26 m	0.33	0.39
180°	9.82 m	15.31 m	1.77 m	2.07 m	0.32	0.61
210°	9.43 m	14.63 m	1.28 m	1.92 m	0.43	0.38
240°	8.52 m	11.55 m	1.07 m	2.04 m	0.33	0.41
270°	6.76 m	10.43 m	1.98 m	1.65 m	0.30	0.52
300°	7.08 m	10.10 m	1.49 m	1.86 m	0.33	0.41
330°	7.41 m	10.49 m	1.34 m	2.07m	0.30	0.52

Recorded alert distance measurements for both the PPU and EPU experimental trials were displayed on coverage area graphs. Figure 41 shows the median PPU recorded alert distance measurement for each approach angle.

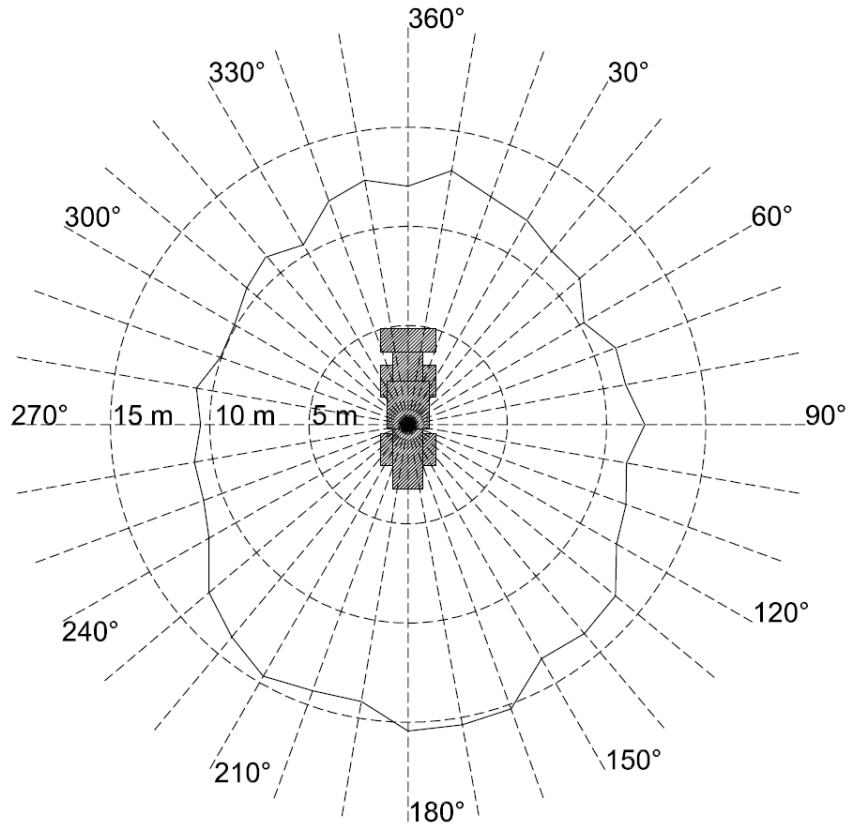

Figure 41: Active proximity warning zone for PPU alert

8.4.3 Mobile Equipment with Static Worker

The second set of experimental trials within the prescribed testing method evaluated the effectiveness the proximity detection system on a static test person and mobile wheel loader. The same flat, unobstructed surface was used to conduct these trials. Five ground markers were positioned at 4 meter intervals along the straight line parallel to the wheel loader’s travel path (Figure 42). The wheel loader approached the test person at a constant speed of 8 kilometers per hour and stopped once the EPU alert was activated for 32 trials. The PPU was positioned at the static location of the test person in the two following locations:

- 1) 0 meter vertical distance from the ground surface and
- 2) 1.5 meter distance from the ground surface.

For both of the PPU position, the wheel loader approached the test person traveling in the forward direction and reverse direction. Data obtained from these trials was analyzed using the same statistical criteria discussed in the previous experiment. No false positive or nuisance alerts were recorded during the trials. Results can be viewed in Figure 42. The notation along the horizontal axis for each plot uses the following notation: (wheel loader travel direction, vertical distance of PPU from the ground surface).

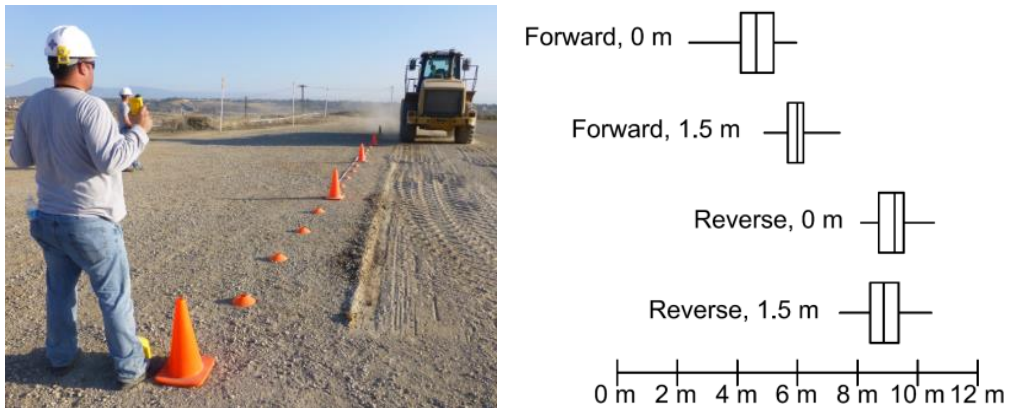

Figure 42: Mobile equipment and static worker experiment (left); boxplot of proximity alert distances (right)

Table 24 shows the statistical range, standard deviation, and interquartile range for each of the four experimental scenarios. The reverse travel direction experienced a longer distance alert range than forward possibly due to the mounting position of the EPU

antenna. The highest statistical range value (3.6 meters) was experienced when the PPU was placed on the ground and the wheel loader traveled in the forward direction. The lowest statistical range value (2.4 meters) occurred when the PPU was at the ground level and the wheel loader traveled in the reverse direction. The highest interquartile range was recorded when the PPU was located on the ground and the wheel loader traveled forward. The lowest interquartile range was experienced when the PPU was located at 1.5 meters vertical from the ground surface and the wheel loader traveled in the forward direction.

Table 24: Statistical analysis of mobile equipment with static worker alert distances

Travel Direction	Forward	Forward	Reverse	Reverse
PPU Height	0 m	1.5 m	0 m	1.5 m
Range	3.6 m	2.5 m	2.4 m	3.1 m
Standard Deviation	0.7 m	0.5 m	0.6 m	0.8 m
Interquartile Range	1.1 m	0.5 m	0.8 m	1.0 m

8.4.4 Obstructed PPU

To evaluate the reliability and effectiveness of the proximity detection system while the LOS between the EPU and PPU component was obstructed, a set of experimental trials were designed and executed to simulate this condition in the same previously created test bed. A crew cab maintenance truck was positioned perpendicular to the wheel loader’s travel path such that the back of the truck was aligned with the ground markers such that the truck would obstruct the LOS between the EPU and PPU. The PPU was vertically positioned 0.9 meter from the ground surface and horizontally located 1.3 meters perpendicular from the wheel loader’s travel path such that the truck was between the EPU and PPU (see Figure 43). The wheel loader approached the PPU at a constant speed and stopped once the EPU alert was activated for 32 trials in both the

forward and reverse travel direction. Results of the obstructed PPU experiments are shown in Figure 43.

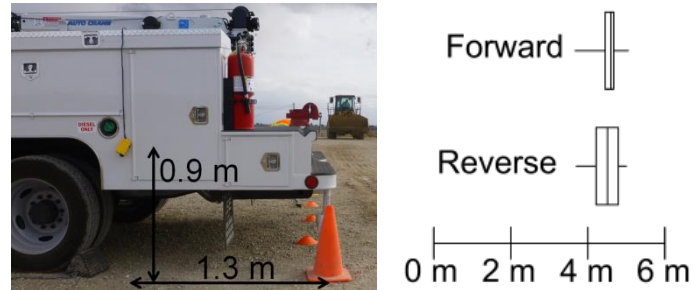

**Figure 43: Mobile equipment and static worker obstructed PPU experiment (left);
boxplot of proximity alert distances (right)**

The interquartile range of the forward travel direction data was smaller when compared to the reverse travel direction, but the range of both data was within 0.1 meter. The standard deviation for the forward and reverse travel direction was 0.4 and 0.3 respectively. When placing the PPU on the ground surface directly behind the truck's tire wheel, both the PPU and EPU alerts were not activated.

8.4.5 Mobile Equipment with Mobile Worker

The final set of experimental trials of the proximity detection and alert system testing method was completed to evaluate the reliability of the proximity detection system when both ground worker and construction equipment are mobile. The LOS between the PPU and EPU was not intentionally obstructed, and the PPU was held by the ground worker at approximately 1.5 meters vertically above the ground surface. The ground worker and wheel loader begin to travel towards each other along a straight path

at the same time. The wheel loader traveled in the reverse towards the ground worker. The ground worker traveled at approximately 2 meters per second and the wheel loader traveled at approximately 8 kilometers per hour. Both the ground worker and wheel loader operator stop moving at the moment they heard their respective alerts and the horizontal alert distance was measured from the PPU position to the closest wheel loader component (rear bumper nearest the test person). The experimental test bed and process can be viewed in Figure 44.



Figure 44: Mobile equipment and mobile worker experiment

For all 32 trials completed, the wheel loader and ground worker stopped before intersecting travel paths. The range of the trials was 4.5 meters while the standard deviation was 1.3. The minimum measured alert distance was 3.5 meters, the maximum measured alert distance was 8.0 meters, and the interquartile range of the measured alert distances was 1.6 meters.

8.4.5 Summary of Testing Method for Proximity Detection and Alert Systems

The experimental trials described in this section serve as the different components for the testing method for proximity detection and alert systems. Users of this testing method should follow the prescribed experimental trials and resulting data collection and

analysis methods. Table 25 provides a breakdown of the testing method for proximity detection and alert systems on construction sites.

Table 25: Components of the testing method for proximity detection and alert systems

Trial 1: Technology Selection

Trial Description: Select a system thought to be capable of performing in the construction environment

System Standards:

- 1) Distinguish between people and objects
- 2) Alerts are identifiable over general construction noise
- 3) Activate real-time alerts for workers and/or operators
- 4) Detection range is an adequate distance for construction equipment
- 5) Function on construction sites
- 6) Minimal required infrastructure

Trial 2: Coverage Area

Description: Test the system's ability to detect and alert when construction equipment is static and the worker is mobile

System Standards:

- 1) Alert must be activated upon each approach before the worker contacts the equipment (no false negative alerts)
- 2) All alert distances must be within three times the inner-quartile range value (no false positive alerts)
- 3) Alert must activate for each approach angle

Trial 3: Mobile Equipment with Static Worker

Description: Test the system's ability to detection and alert when construction equipment is mobile and the worker is stationary

System Standards:

- 1) Alert must be activated before the construction equipment reaches the stationary worker for each pass (no false negative alerts)
 - 2) All alert distances must be within three times the inner-quartile range value (no false positive alerts)
 - 3) Alert distance must have length such that the construction equipment comes to a complete stop before reaching the stationary test person for each pass
-

(Table 25 continued)
Trial 4: Obstructed PPU

Description: Test the system's ability to detect and alert when equipment is mobile and the PPU is static and obstructed by an object or equipment

System Standards:

- 1) Alert must be activated before the construction equipment reaches the stationary PPU for each pass (no false negative alerts)
 - 2) All alert distances must be within three times the inner-quartile range value (no false positive alerts)
 - 3) Alert distance must have length such that the construction equipment comes to a complete stop before reaching the stationary PPU
-

Trial 5: Mobile Equipment and Mobile Worker

Description: Test the system's ability to detect and alert when construction equipment is mobile and the worker is mobile

System Standards:

- 1) Alert must be activated before the construction equipment reaches the mobile worker (no false negative alerts)
 - 2) All alert distances must be within three times the inner-quartile range value (no false positive alerts)
 - 3) Alert distance must have length such that the construction equipment comes to a complete stop before reaching the mobile worker
-

8.5 Conclusion

The safety practices currently used in the construction industry for ground workers and heavy equipment operating in close proximity has proven inadequate by the continued injuries and fatalities resulting from workers being struck by equipment or objects. The purpose of this research was to create and evaluate a testing method capable of assessing the reliability and effectiveness of proximity detection and alert systems used in the construction environment. Results obtained from implementing the testing method on a proximity detection and alert system indicate that a magnetic field proximity detection and alert system could provide an additional layer of protection for ground workers on construction sites.

A testing method was design with experiments to reveal the ability of a proximity detection and alert system to provide alerts in real-time for ground workers and heavy equipment operators during hazardous proximity situations. Four experiments simulating various human and heavy equipment interactions were completed to demonstrate the testing method for proximity detection and alert systems. Analyzed data (alert distance measurements) demonstrated the system's ability to detect the presence of hazardous proximity situations on construction sites in real-time. If users of the test method experience undesirable results when performing the four prescribed trials, the user should conduct further testing such as field test without construction equipment as described in chapter 7 of this thesis.

Furthermore, surveyed workers indicated the audible alert was differentiated from other common equipment alarms and construction site noise. The alert was activated for each trial resulting in no false negative alarms meaning the system activated an alert each time a proximity breach occurred. At the conclusion of the experimental trials of the testing method, participants should be involved in discussions to express their opinions about the effectiveness of the technology. These discussions can potentially reveal limitations of the technology not identified through experimental trials of the testing method. Results from the magnetic field proximity detection and alert system indicate that systems using magnetic field technology can more reliability and effectively provide alerts during hazardous situations on construction sites than the evaluated RF systems.

The field trials with the magnetic field proximity detection and alert system were deemed successful; however other parameters were noted that could potentially have an influence on the system. Further testing for this specific system is required to better

understand the impact of metallic surfaces directly touching the EPU antenna, interferences from other wave frequencies (such as cellular phones), and reliability of PPU obstructed when placed on the ground surface. These variables should be further tested in both laboratory field settings and in simulated or actual construction environments. Unique experiments can be designed and implemented into the proposed testing method depending on specific situations of a construction company or site conditions. These experiments will allow for more evaluation of the reliability of magnetic field proximity detection systems. Prior to implementation, the system should be deployed in an active construction environment on actual ground workers and heavy equipment performing various construction tasks.

The presented testing method provides a foundation for evaluating the capabilities of proximity detection and alert systems in the construction environment. The testing method was validated by performing the testing method of a magnetic field proximity detection and alert system. More detailed experiments may be required to further test specific capabilities of the system depending on the site conditions. Barriers identified when executing this testing method should also be further investigated through interviewing site personnel and experimentation.

CHAPTER 9

CONCLUSIONS

The intent of this chapter is to summarize and offer concluding remarks for this research. The chapter specifically addresses the research needs statement as well as the research questions presented in Chapter 3 of this thesis. Major findings of the research, identified limitations, and future research extensions of this work are discussed in this concluding chapter.

9.1 Concluding Remarks

The construction industry has historically been one of the leading industries for workplace fatalities [4]. Governmental regulatory agencies, such as OSHA, require construction companies to record and report workplace accidents including illnesses, injuries, and fatalities which are categorized as safety lagging indicators [13]. Safety leading indicators, such as reporting near misses, allow for a worker safety performance measurement without requiring accident data. By reporting and analyzing near misses, potentially hazardous conditions or worker behaviors on construction sites can be identified before an illness, injury, or fatality occurs. Safety managers and other construction site personnel can disseminate near miss information into worker safety education and training.

Contact collisions between ground workers and construction equipment account for 19% of construction fatalities per year [1]. Current safety requirements with regards to hazardous proximity situations in construction are inadequate. Sensing technology is

capable of alerting construction site personnel during hazardous proximity situations and recording these near miss events. Various applications of sensing technology for enhanced safety performance of workers during hazardous proximity situations are available. This technology allows for real-time decision making through alerts for workers as well as near miss data for safety management to assess.

Research questions were presented in Chapter 3 of this thesis. These research questions and a summarized discussion are presented in the following:

- 1) *Can near miss events be recorded and analyzed to increase awareness of potential hazards on construction sites?*

The background review section (Chapter 2) of this thesis discussed a motivation for capturing safety leading indicator data including near misses. It is theorized that a multitude of near misses occur for each injury or fatality experienced on a construction site. Chapter 4 of this thesis presented a near miss reporting program available for implementation into a construction company. This program provided a methodology to record, analyze, and disseminate gained knowledge throughout the company. By incorporating newly identified site hazards or hazardous worker behavior into worker safety education and training, construction site personnel can become more aware of potential hazards.

- 2) *Can operator visibility be measured and analyzed for education of equipment operators of invisible areas around construction equipment?*

Limited operator visibility was identified as one of the leading causes for contact collisions between ground workers and equipment operators that resulted in injuries or fatalities. Current methods of measuring operator visibility (as prescribed by the ISO codes) are time and structurally intensive. The method presented in Chapter 5 allows for more operator visibility analysis and resulting information than is available with the current method. For example, the laser scanning and data processing cumulative time is approximately one hour compared to several hours required for the current prescribed ISO code method for the same result. Design components of skid steer loaders are also evaluated with regards to their impact on operator visibility.

- 3) *Are proximity detection and alert systems capable of detecting, and alerting construction personnel and equipment operators in real-time of hazardous situations?*

Contact collisions between construction equipment and ground workers cause a significant amount of workplaces fatalities and injuries each year. Sensing technology deployed in experimental test beds designed to emulate construction environment conditions demonstrated their ability to detect and record situations in which a ground worker breached a pre-defined hazard zone. One proximity

detection and alert system was able to reliably detect the presence of a proximity breach and provide alerts to ground workers and equipment operators in real-time. These experimental trials and results are presented in Chapter 6, 7, and 8 of this thesis.

4) *How should proximity detection and alert systems be evaluated for potential deployment onto construction sites?*

Many industry sectors in the U.S. are benefitting from the capabilities of sensing technology. Proximity detection and alert technology have been implemented in other industries to minimize human-equipment contact collisions. A test method was created (Chapter 8) to evaluate the capabilities of proximity detection and alert systems when deployed in the harsh construction environment. Equipment obstructions and movement of construction equipment and ground workers were evaluated and incorporated into the test method. By creating a testing standard, construction companies can evaluate proximity detection and alert systems from several manufacturers to better understand which systems can meet their specific safety needs.

The scientific contributions of this thesis are summarized in the following:

- A near miss reporting program available for implementation by a construction company. Aspects of the program including program guidelines, near miss database template and program evaluation tool are discussed.
- A test method to evaluate the reliability and effectiveness of proximity detection and alert systems when deployed in the harsh construction environment.
- A test bed designed to emulate typical interactions between ground workers and construction equipment in the construction environment.
- Scientific experimental evaluation data of several proximity detection and alert systems and concluding remarks.
- Operator visibility measurement and analysis including visibility maps for various pieces of construction equipment.

9.2 Limitations and Future Research

Although safety leading indicators provide a safety measurement method that can identify hazards and predict potential worker illnesses, injuries, or fatalities, data analysis is accomplished only after a safety leading indicator is identified. Other than providing real-time alerts for workers who breach pre-defined hazard zones, other hazard mitigation efforts resulting from analyzed safety leading indicator data are not available in real-time.

All of the construction site personnel interviews conducted were of employees within construction companies who have previously implemented a near miss reporting program (see Chapter 4). Interview candidates were selected by willing companies which

excluded construction companies that had no near miss reporting program. Future research efforts could integrate responses from construction companies that choose not to implement a near miss reporting program.

Research limitations associated with the operator visibility measurement data (see Chapter 5) is based on a static blind spot in which the operator holds his/her head at a constant elevation and position. Dynamic blind spots are more representative of operator visibility on construction jobsites. Because analysis effort of the operator visibility measurement data was manually performed, one future research step would be to fully automate the process. Other researchers have implemented dynamic blind spot mapping for operator visibility [63]. It would also be useful to integrate operator visibility measurement with proximity detection and alert systems for real-time alerts of workers in invisible areas around pieces of construction equipment.

Several research limitations are found in the evaluated proximity detection and alert system. A multitude of conditions and variables were evaluated, but other scenarios were not included in this work. Although a complete coverage area was obtained around many pieces of construction equipment, the best mounting position for both the PPU and EPU were not identified. These mounting positions could have an impact on the pre-defined proximity read range and the coverage area. Nuisance alerts were documented and analyzed, but limited attempts were made to eliminate these alerts. Further research is also needed to calibrate the system for specialized alert distances for individual pieces of construction equipment including operator and worker reaction time, operator brake distances, ground surface preparation and weather conditions. Lastly, all of the

components of the proximity detection and alert system evaluation should be tested in a long-term active construction environment.

APPENDIX A

CONSTRUCTION SITE PERSONNEL INTERVIEW QUESTIONS

This appendix shows the interview tool administered to construction site personnel on projects with near miss reporting programs in sections A.1, A.2, and A.3. The first set of questions (see A.1) were given to safety managers, the second set to supervisors including foremen (see A.2), and the final set were given to craft workers and laborers (see A.3). Section A.4 contains the paper report form made available to workers on various locations throughout the construction site. A near miss reporting database query by severity of the event is shown in section A.5.

A.1 Interview Questions for Safety Managers

Interviewee Information

- 1) How long have you been a safety manager?
- 2) How long have you been on this project?
- 3) Is your time solely dedicated to this project?

Company Profile

- 1) What type of service does your firm provide (construction, owner etc.)?
- 2) What sector describes most of your firm's projects (e.g., industrial, energy, infrastructure, heavy industrial, commercial, heavy/highway)?
- 3) What is the approximate annual revenue of your company?
- 4) How many individuals does the company employ (approximate)?
- 5) How many of these are field workers?
- 6) What is the company's OSHA Recordable Injury Rate (TRIR per 200,000 w-h)?

Project Information

- 1) What type of project is this (e.g., industrial, energy, infrastructure, heavy industrial, commercial, heavy/highway)?
- 2) Location of the project:
- 3) What is the method of project delivery (e.g. CM, CM at Risk, GC, Design-Build)?
- 4) What is the approximate dollar value of this project?
- 5) What is the approximate percent complete?
- 6) How many craft workers are employed on this project (including subcontractors)?
- 7) How many first-line supervisors (or foremen) are employed on this project?
- 8) How many safety personnel are employed on this project site?

- 9) How many worker-hours have accumulated for this project?
- 10) What is the project's OSHA Recordable Injury Rate (TRIR per 200,000 w-h)?
- 11) Does the project maintain a first aid log?
- 12) How many first aid injuries have been reported?

Near Miss Reporting Program

- 1) Is there a near miss reporting and analysis program?
- 2) Which party initiated the implementation of the near miss reporting program (contractor or owner)?
- 3) How are near misses defined?
- 4) Who reports the occurrence of near misses? (workers, supervisors, anyone?)
- 5) How are near misses reported? (verbal, written, automated, etc.)
- 6) Are you using any technology to record or report near misses? If yes, how effective is it and how can it be improved?
- 7) How do workers find out about the near miss program?
- 8) How are workers encouraged to report near misses?
- 9) Who receives the near miss reports?
- 10) Who assesses the merits of investigating near misses?
- 11) Who investigates the near misses?
- 12) How many near misses have been reported on this project?
- 13) How many near misses have been investigated on this project?
- 14) What is your opinion about the effectiveness or value of the near miss reporting program?
- 15) Describe any aspect of the near miss reporting program that could be improved.
- 16) Do you feel that some workers are reluctant to report near misses? If yes, why?
- 17) What is the single more important thing that you do to help ensure that the near miss reporting program is a success?
- 18) Is there a worker-to-worker observation project in place on the project?
- 19) If yes to question 18, approximately how many observations have been made on this project?
- 20) Is there a stop work authority program on the project?
- 21) If yes to question 20, approximately how often has work been stopped by a worker who observed that work was being done in an unsafe manner?
- 22) How many of these incidents have been investigated and officially documented?
- 23) Is any of the near miss data for this project available for use by the research team?

A.2 Interview Questions for Foremen

- 1) What is your trade?
- 2) How long have you been working in construction?
- 3) How long have you been working on this this project?
- 4) How many workers are typically in your crew?
- 5) Describe the near miss reporting program on this project?
- 6) Can you explain what a near miss is?
- 7) How many near misses have workers in your crew reported in the past 6 months?

- 8) How were those recorded and reported to upper management (manually vs. use of any technology)?
- 9) Do you encourage your workers to report near misses?
- 10) If yes for question 9, how do you encourage near miss reporting?
- 11) Do you feel that some workers are reluctant to report near misses? If yes, why?
- 12) Do you feel that the near miss program is good for promoting safety?

A.3 Interview Questions for Workers

- 1) What is your trade?
- 2) How long have you been working in construction?
- 3) How long have you been employed on this project?
- 4) Are you familiar with the near miss reporting program on this project? If yes, describe the program
- 5) How did you learn about the near miss reporting program?
- 6) Have you reported any near misses on this project? If yes, how many?
- 7) If applicable, describe a near miss you have reported.
- 8) What feedback have you received on near misses that you have reported?
- 9) How did you report it (manual vs. using technology)?
- 10) If no on question 9, have you seen any near misses that you or someone could have reported?
- 11) What is supposed to happen with information about near misses that are reported?
- 12) Is information about near misses that have happened on other parts of the project or on other projects shared with you?
- 13) Explain what a near miss is.
- 14) Do you feel that some workers are reluctant to report near misses? If so, why?

A.4 Near Miss Reporting Form

Near Miss/Unsafe Condition Report

PROJECT: _____
 INCIDENT TYPE: _____
 INCIDENT DATE: _____
 SS/RISK POTENTIAL: _____
 TYPE OF EVENT: _____

Check One	
3 Critical Severity	<input type="checkbox"/>
2 Moderate Severity	<input type="checkbox"/>
1 Low Severity	<input type="checkbox"/>

Location/Elevation/Equipment

Employees Involved

1. What happened? (Description of Incident)

2. What unsafe acts and/or conditions contributed to this incident? (Immediate Cause)

3. What are the underlying or root causes which allowed the above factors to exist? (Contributing Cause)

4. What actions have or will be taken to prevent recurrence? Expected completion date of each? (Corrective Action)

Investigated by:	Reviewed by:	Reviewed by:
Title: _____	Title: _____	Title: _____
Name: _____	Name: _____	Name: _____
Signature: _____	Signature: _____	Signature: _____

Resolution Reviewed by: _____

Title: _____

Name: _____

Signature: _____

Date Corrective Action Finalized: _____

Near Miss: An unplanned event or unsafe condition that has the potential for injury or illness to people, or damage to the property, or the environment

Figure A.1: Near Miss/Unsafe Condition Reporting Form

A.5 Near Miss Reporting Database Query by Severity

Severity	ID	Project	Date	Time
3	5	ABC Towers	07-Nov-13	11:35:00 AM
2	3	ABC Towers	13-Nov-13	12:15:00 PM
2	6	ABC Towers	04-Nov-13	3:25:00 PM

15 January, 2014 Page 1 of 1

Figure A.2: Near Miss Database Report Query

A.6 Near Miss Program Evaluation Tool User Questions

Section 1: Project Information

- 1) Project Name:
- 2) Number of craft workers:
- 3) Cumulative worker hours:
- 4) Cumulative number of near misses reported:
- 5) Cumulative number of near misses investigated:

Section 2: Define

- 1) A near miss reporting program is encouraged or required by the corporate office.
- 2) A near miss reporting program is implemented on every project.
- 3) The definition of a near miss is clearly understood by management.
- 4) A near miss reporting program is implemented on my current project.
- 5) The definition of a near miss is clearly understood by the craft workforce.
- 6) All workers are expected to report near misses.
- 7) Owners require a near miss program as a prequalification requirement for contractors.

Section 3: Roll Out

- 1) All onsite craft personnel have completed specific near miss training.
- 2) The project has specific training materials to define and explain the near miss reporting program.
- 3) Worker training incorporates exercises to assist in identifying near misses.
- 4) Workers are trained on the barriers to reporting near misses.
- 5) Management personnel on the project have been trained on how to act and react to reported near misses.
- 6) Administrative requirements of the near miss reporting program have been taken into account.

Section 4: Collect

- 1) The collection method enables workers to anonymously report near misses.
- 2) Collected near misses are reviewed by project management personnel.
- 3) Rate the ease of using and understanding the method for collecting near misses for craft workers.
- 4) Collected near misses are reviewed by safety managers.
- 5) Near misses can be verbally reported on the project.
- 6) Workers are expected to enter near misses into a database.
- 7) Supervisors are expected to enter near misses into a database.
- 8) The project uses a database to collect and analyze reported near misses.

Section 5: Analyze

- 1) The near miss database is analyzed for trends (for example time, data, severity, craft, and demographic).
- 2) All near misses are investigated.
- 3) All reported near misses are analyzed for potential consequences.
- 4) A team with several different project personnel are involved in the investigative team.
- 5) The investigative team determines the “root cause” of a reported near miss.
- 6) Near misses must be assessed within a determined time frame set by a safety manager.

Section 6: Analyze

- 1) The investigation team recommends corrective action based on investigation findings
- 2) Management determines corrective actions based on investigation team recommendations.
- 3) Implemented corrective actions are effective in preventing future incidents.
- 4) Corrective actions are implemented in a timely manner.

Section 7: Share

- 1) Project personnel that have access to near miss reports include:
- 2) The investigation team creates a summary of the near miss and findings to be distributed to other site personnel.
- 3) Reported near misses are shared with the craft workforce.
- 4) Trends identified from the near miss analysis are shared with the craft workforce.
- 5) Investigative findings are shared with the craft workforce.
- 6) Construction site management personnel review near miss information with the craft workforce.
- 7) Investigative findings are shared company-wide.
- 8) The safety manager disseminates knowledge generated from the analysis of the near miss reporting data for safety training and education.
- 9) Near miss reports are accessible and shared with safety managers across projects.

Section 8: Encourage

- 1) Workers are comfortable reporting near misses.
- 2) Each construction site has a recognition program for near miss reporting.
- 3) Management response to a reported near miss is appropriate for the identified potential.
- 4) Workers are publically recognized for reporting a near miss.
- 5) Management reaction to a reported near miss encourages additional reporting.
- 6) Workers are privately recognized for reporting a near miss.

APPENDIX B

CONSTRUCTION EQUIPMENT OPERATOR VISIBILITY

MEASUREMENT RESULTS

This appendix shows results from the construction equipment operator visibility measurements. The following pieces of construction equipment were measured for operator visibility: Asphalt paver (section B.1), excavator (section B.2), vibratory roller (section B.3), and forklift (section B.4). A plan view visibility map, summary of the plan view measurements, a rear and front view visibility map, summary of front and rear view measurements, a side view visibility map, and a summary of the side view measurements is presented for various pieces of construction equipment evaluated.

B.1 Summary of Asphalt Paver Visibility Measurement

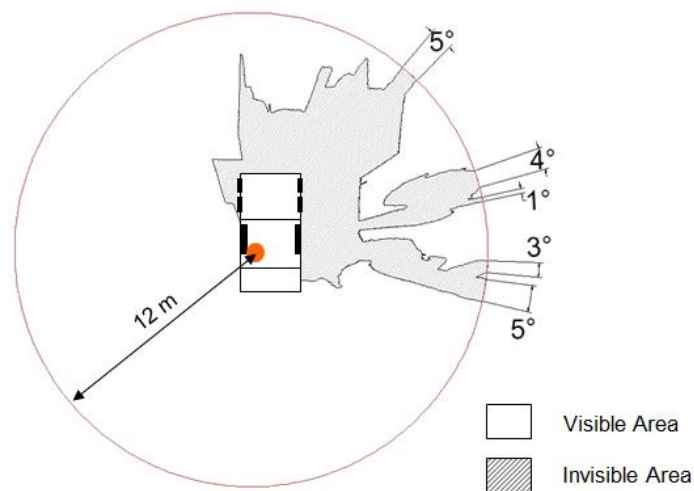

Figure B.1: Asphalt paver plan view of laser scan data

Table B.1: Summary of plan view asphalt paver operator visibility

Item	Measurement
Area of full circle	452.2 m ²
Area occupied by equipment	19.5 m ²
Blind spot area	89.5 m ²
Length of circumference (full circle)	75.4 m
Visible length circumference	71.6 m
Percent visible circumference	95.0 %
Percent blind spot	15.5 %

Table B.2: Summary of front/rear view asphalt paver operator visibility

Item	Measurement
Visibility of an object in the front of the equipment	52.2%
Visibility of an object in the rear of the equipment	100.0%

Table B.3: Summary of side view asphalt paver operator visibility

Item	Measurement
Visibility of an object on the left side of the equipment	100.0%
Visibility of an object on the right side of the equipment	45.3%

B.2 Summary of Excavator Visibility Measurement

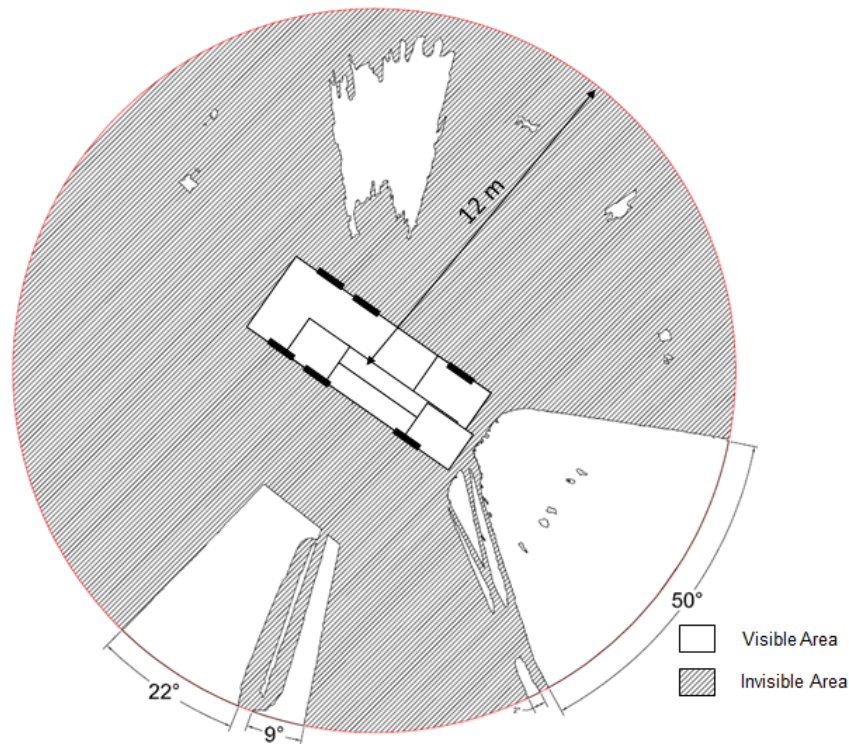

Figure B.2: Excavator plan view of laser scan data

Table B.4: Summary of plan view excavator operator visibility

Item	Measurement
Area of full circle	452.2 m ²
Area occupied by equipment	20.9 m ²
Blind spot area	355.7 m ²
Length of circumference (full circle)	75.4 m
Visible length circumference	58.4 m
Percent visible circumference	77.5 %
Percent blind spot	78.7 %

Table B.5: Summary of front/rear view excavator operator visibility

Item	Measurement
Visibility of an object in the front of the equipment	0.0 %
Visibility of an object in the rear of the equipment	0.0 %

Table B.6: Summary of side view excavator operator visibility

Item	Measurement
Visibility of an object on the left side of the equipment	0.0%
Visibility of an object on the right side of the equipment	25.3%

B.3 Summary of Vibratory Roller Visibility Measurement

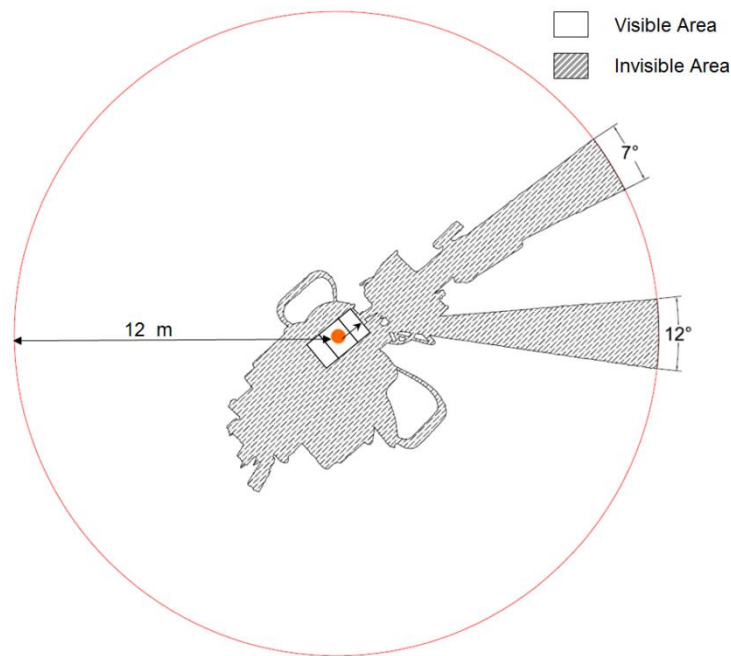

Figure B.3: Vibratory roller plan view of laser scan data

Table B.7: Summary of plan view vibratory roller operator visibility

Item	Measurement
Area of full circle	452.2 m ²
Area occupied by equipment	5.84 m ²
Blind spot area	57.8 m ²
Length of circumference (full circle)	75.4 m
Visible length circumference	71.4 m
Percent visible circumference	94.7 %
Percent blind spot	12.8 %

Table B.8: Summary of front/rear view vibratory roller operator visibility

Item	Measurement
Visibility of an object in the front of the equipment	53.3 %
Visibility of an object in the rear of the equipment	47.3 %

Table B.9: Summary of side view vibratory roller operator visibility

Item	Measurement
Visibility of an object on the left side of the equipment	82.7%
Visibility of an object on the right side of the equipment	47.3%

B.4 Summary of Forklift Visibility Measurement

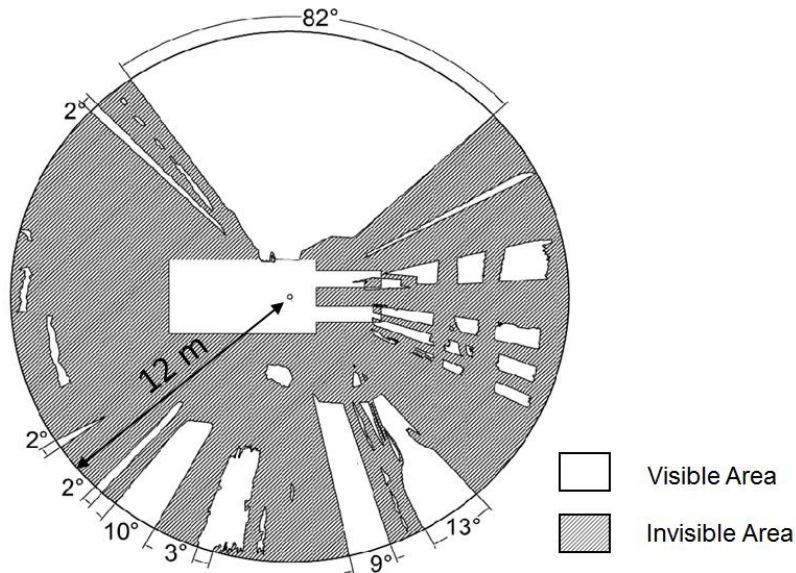

Figure B.4: Forklift plan view of laser scan data

Table B.10: Summary of plan view forklift operator visibility

Item	Measurement
Area of full circle	452.2 m ²
Area occupied by equipment	23.8 m ²
Visible length circumference	49.6 m
Blind spot area	271.3 m
Length of circumference (full circle)	75.4 m
Visible length circumference	49.6 m
Percent visible circumference	65.8%
Percent blind spot	60.0 %

APPENDIX C

COVERAGE AREA MAPS OF PROXIMITY DETECTION AND

ALERT SYSTEMS INSTALLED ON CONSTRUCTION

EQUIPMENT

Figures in Appendix C show the plan view of the proximity alert range for select pieces of heavy construction equipment. Each figure shows the coverage area alert distance for each piece of construction equipment. Results indicate that for larger pieces of construction equipment, several EPU antennas are required to achieve full coverage around the equipment footprint. The following pieces of construction equipment were tested: Grader, excavator, truck and trailer, pick-up truck, vibratory roller, and dump truck.

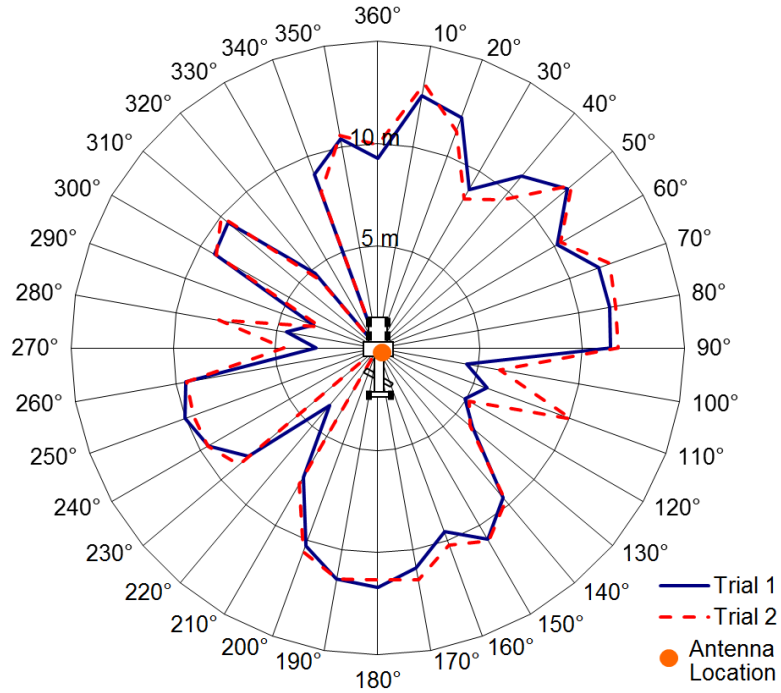

Figure C.1: Grader proximity warning zone for a specific calibrated alert range

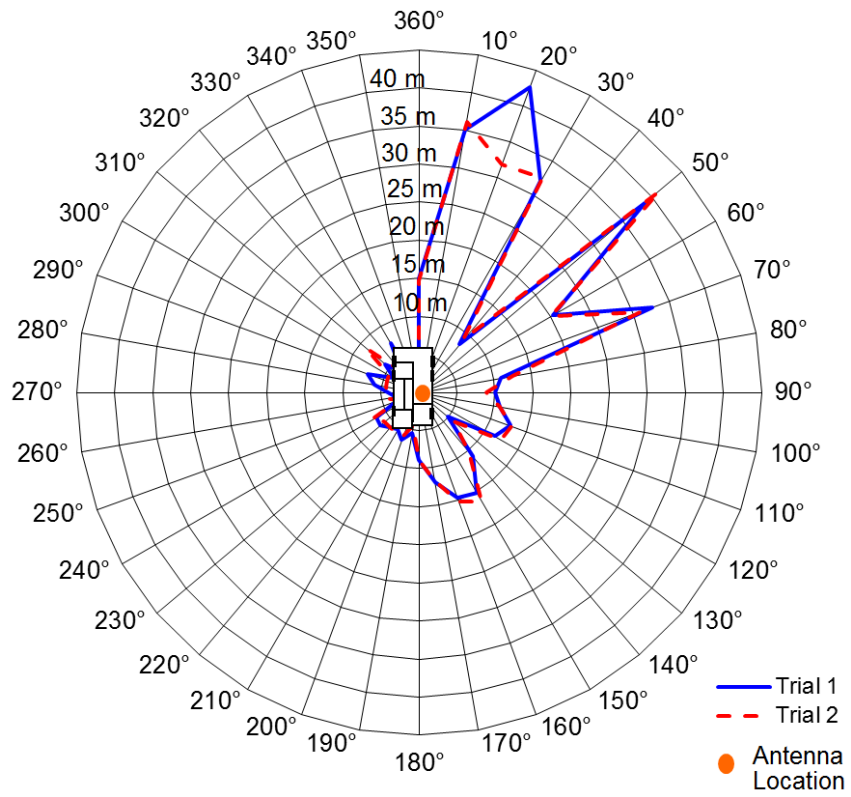

Figure C.2: Excavator proximity warning zone for a specific calibrated alert range

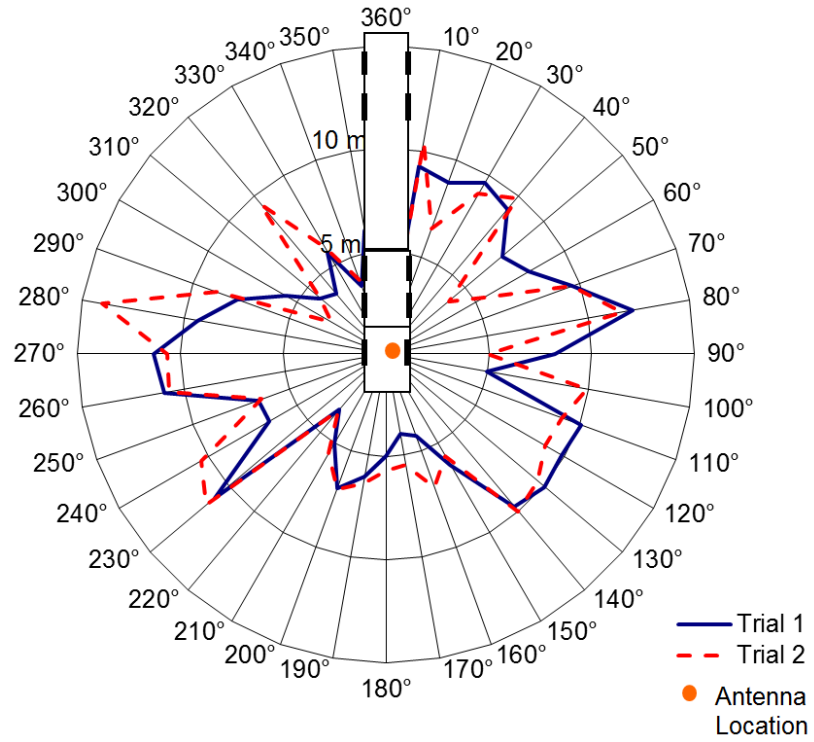

Figure C.3: Truck and trailer proximity warning zone for a specific calibrated alert range

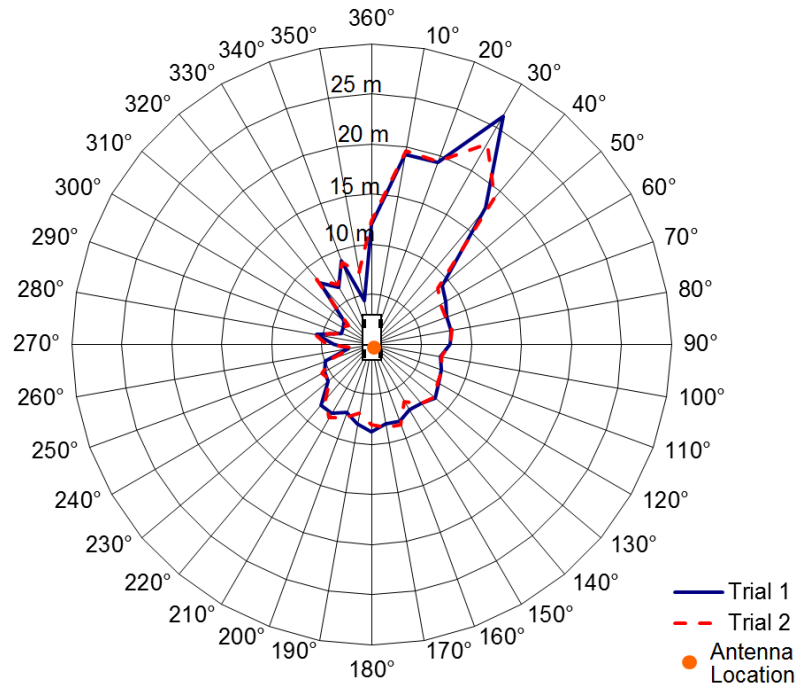

Figure C.4: Pick-Up Truck proximity warning zone for a specific calibrated alert range

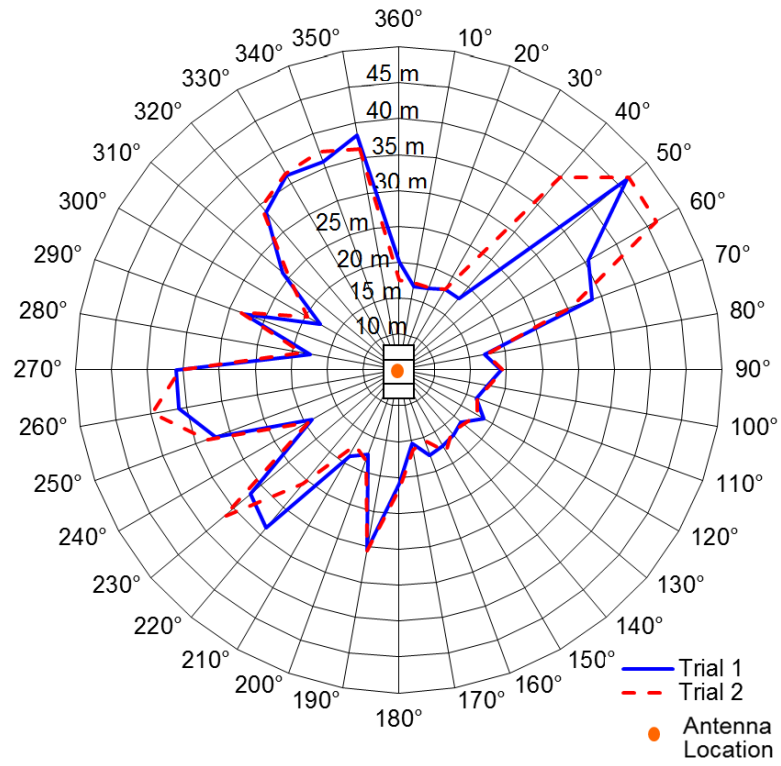

Figure C.5: Vibratory roller proximity warning zone for a specific calibrated alert range

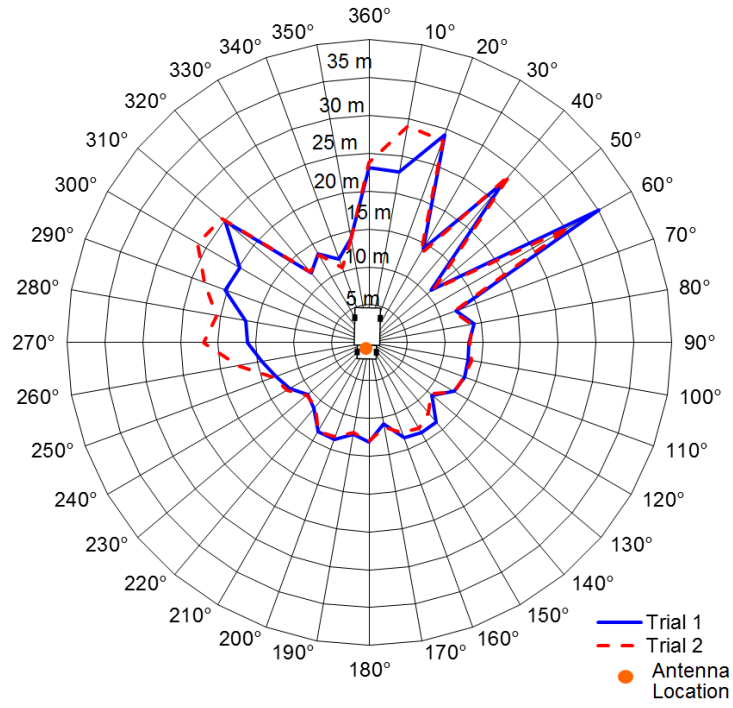

Figure C.6: Dump truck proximity warning zone for a specific calibrated alert range

APPENDIX D

PROXIMITY DETECTION AND ALERT PPU POSITION AND ORIENTATION EXPERIMENTAL RESULTS

This appendix shows results from PPU orientation and position experiments when the PPU was mounted on both a worker's hard hat and safety vest. These results are a continuation of results presented in Chapter 7.

Table D.1: Semi-passive tag orientations mounted on the side of a hard hat

		PPU 1	PPU 2	PPU 3
Orientation 1	Mean:	8.9 m	5.7 m	7.3 m
	Range:	1.0 m	2.5 m	4.5 m
	Std. Dev.:	0.5	1.3	2.3
Orientation 2	Mean:	5.3 m	5.3 m	7.4 m
	Range:	1.8 m	1.5 m	5.3 m
	Std. Dev.:	0.9	1.5	2.7
Orientation 3	Mean:	6.5 m	3.1 m	8.6 m
	Range:	2.8 m	3.3 m	1.3 m
	Std. Dev.:	1.4	1.6	0.6
Orientation 4	Mean:	2.6 m	3.1 m	7.9 m
	Range:	1.5 m	1.5 m	2.5 m
	Std. Dev.:	0.8	0.8	1.4

Table D.2: Semi-passive tag orientations mounted on the front of a hard hat

		PPU 1	PPU 2	PPU 3
Orientation 1	Mean:	36.5 m	38.2 m	38.4 m
	Range:	3.0 m	3.5 m	1.8 m
	Std. Dev.:	1.5	1.9	1.0
Orientation 2	Mean:	11.7 m	9.4 m	22.2 m
	Range:	3.0 m	1.3 m	1.5 m
	Std. Dev.:	1.6	0.6	0.8
Orientation 3	Mean:	36.1 m	10.8 m	36.8 m
	Range:	3.3 m	0.5 m	2.0 m
	Std. Dev.:	1.6	0.3	1.0
Orientation 4	Mean:	7.2 m	7.6 m	14.3 m
	Range:	4.3 m	5.8 m	3.3 m
	Std. Dev.:	2.1	2.9	1.6

Table D.3: Semi-passive tag orientations mounted on the back of a hard hat

		PPU 1	PPU 2	PPU 3
Orientation 1	Mean:	9.8 m	14.4 m	10.6 m
	Range:	2.0 m	3.8 m	1.8 m
	Std. Dev.:	1.0	1.9	1.0
Orientation 2	Mean:	10.8 m	3.4 m	6.8 m
	Range:	1.3 m	1.8 m	4.3 m
	Std. Dev.:	0.7	1.0	2.4
Orientation 3	Mean:	5.8 m	28.8 m	26.8 m
	Range:	5.5 m	6.3 m	7.8 m
	Std. Dev.:	3.2	3.3	3.9
Orientation 4	Mean:	4.0 m	1.8 m	8.9 m
	Range:	2.5 m	0.5 m	3.3 m
	Std. Dev.:	1.3	0.3	1.6

Table D.4 Semi-passive tag orientations mounted on the front torso of a safety vest

		PPU 1	PPU 2	PPU 3
Orientation 1	Mean:	38.5 m	32.9 m	35.7 m
	Range:	1.0 m	6.5 m	11.5 m
	Std. Dev.:	0.5	3.3	1.3
Orientation 2	Mean:	6.3 m	3.2 m	4.5 m
	Range:	2.0 m	1.0 m	3.8 m
	Std. Dev.:	1.0	0.6	1.9
Orientation 3	Mean:	33.7 m	33.8 m	36.5 m
	Range:	3.0 m	1.5 m	2.5 m
	Std. Dev.:	3.6	0.8	1.3
Orientation 4	Mean:	1.7 m	3.3 m	3.3 m
	Range:	0.5 m	3.5 m	1.3 m
	Std. Dev.:	0.3	1.9	0.7

Table D.5 Semi-passive tag orientations mounted on the back torso of a safety vest

		PPU 1	PPU 2	PPU 3
Orientation 1	Mean:	0.5 m	2.8 m	0.8 m
	Range:	1.0 m	3.0 m	0.5 m
	Std. Dev.:	0.5	1.6	0.3
Orientation 2	Mean:	0.0 m	1.2 m	0.3 m
	Range:	n/a	0.5 m	1.0 m
	Std. Dev.:	n/a	0.3	0.6
Orientation 3	Mean:	2.0 m	0.0 m	0.5 m
	Range:	1.0 m	n/a	1.0 m
	Std. Dev.:	0.5	n/a	0.6
Orientation 4	Mean:	2.1 m	0.0 m	0.0 m
	Range:	1.3 m	n/a	n/a
	Std. Dev.:	0.6	n/a	n/a

Table D.6 Semi-passive tag orientations mounted on the side shoulder of a safety vest

		PPU 1	PPU 2	PPU 3
Orientation 1	Mean:	4.9 m	2.3 m	1.2 m
	Range:	2.8 m	2.0 m	1.5 m
	Std. Dev.:	1.5	1.0	0.8
Orientation 2	Mean:	6.1 m	6.8 m	0.2 m
	Range:	3.8 m	1.5 m	0.5 m
	Std. Dev.:	1.9	0.8	0.3
Orientation 3	Mean:	4.4 m	7.7 m	4.7 m
	Range:	5.0 m	2.0 m	1.5 m
	Std. Dev.:	2.5	1.0	0.8
Orientation 4	Mean:	1.2 m	7.3 m	2.4 m
	Range:	0.5 m	2.0 m	1.3 m
	Std. Dev.:	0.3	1.0 m	0.6

Table D.7 Semi-passive tag orientations mounted on the top shoulder of a safety vest

		PPU 1	PPU 2	PPU 3
Orientation 1	Mean:	6.8 m	3.7 m	24.4 m
	Range:	3.5 m	2.0 m	1.5 m
	Std. Dev.:	2.0	1.0	0.8
Orientation 2	Mean:	2.7 m	4.1 m	2.3 m
	Range:	2.0 m	5.0 m	2.5 m
	Std. Dev.:	1.0	2.5	1.4
Orientation 3	Mean:	8.8 m	8.8 m	5.1 m
	Range:	0.5 m	1.8 m	6.3 m
	Std. Dev.:	0.3	0.9	3.3
Orientation 4	Mean:	2.1 m	1.9 m	5.8 m
	Range:	1.3 m	0.8 m	2.3 m
	Std. Dev.:	0.6	0.4 m	1.2

Table D.8 PPU orientation summary on the safety vest

		PPU 1	PPU 2	PPU 3
Top	Mean:	38.5 m (1)	33.8 m (3)	36.5 m (3)
	Range:	1.0 m (1)	1.0 m (2)	1.3 m (4)
	Std. Dev.:	0.3 (4)	0.6 (2)	0.7 (4)
Side	Mean:	2.1 m (4)	2.8 m (1)	0.8 m (1)
	Range:	1.3 (4)	0.5 m (2)	0.5 m (1)
	Std. Dev.:	0.5 (3)	0.3 (2)	0.3 (1)
Front	Mean:	6.1 m (2)	7.7 m (3)	38.4 m (1)
	Range:	0.5 m (4)	1.5 m (2)	1.5 m (2)
	Std. Dev.:	0.3 (4)	0.8 (2)	0.8 (2)
Back	Mean:	8.8 m (3)	8.8 m (3)	24.4 m (1)
	Range:	0.5 m (3)	0.8 m (4)	1.5 m (1)
	Std. Dev.:	0.3 (3)	0.4 (4)	0.8 (1)

REFERENCES

- [1] Bureau of Labor Statistics. (2013). "Industry at a glance: Construction." U.S. Department of Labor, <<http://www.bls.gov/iag/tgs/iag23.htm>> (June 16, 2013).
- [2] Bureau of Economic Analysis (2013). "Construction." U.S. Department of Commerce, <<http://search.bea.gov/search?query=construction&commit=Go&utf8=%E2%9C%93&affiliate=u.s.bureauofeconomicanalysis>> (Jan. 5, 2014).
- [3] International Labor Organization, (2003). "Safety in numbers." International Labor Organizations, Report Number 61, Switzerland.
- [4] Bureau of Labor Statistics (2013). "Injuries, illnesses, and fatalities." U.S. Department of Labor, < <http://www.bls.gov>> (Dec. 10, 2013).
- [5] Center for Disease Control and Prevention, (2006). "NIOSH fatal occupational injury cost fact sheet: Construction." National Institute of Occupational Safety and Health Publications and Products, 153.
- [6] National Safety Council (2008), "Injury facts, 2008 edition." NSC, <<https://www.usw12775.org/uploads/InjuryFacts08Ed.pdf>>. (Mar. 20, 2013).
- [7] Leigh, P. (2011). "Economic burden of occupational injury and illness in the United States." *Milbank Quarterly*, 89(4), 728-772.
- [8] Bureau of Labor Statistics (2013). "Accident/Incident investigation." U.S. Department of Labor, <http://www.osha.gov/SLTC/etools/safetyhealth/mod4_factsheets_accinvest.html> (June 5, 2013).
- [9] Hinze, J., Thurman, S., and Wehle, A. (2013). "Leading indicators of construction safety performance." *Safety Science*, 51(1), 23-28.
- [10] Grabowski, M., Ayyalasomayajula, P., Merrick, J., Harrald, J., and Roberts, K. (2007) "Leading indicators of safety in virtual organizations," *Safety Science*, 45(1), 1013-1043.

- [11] Pratt, M. and Bonneson, J. (2010). "Development of safety performance monitoring procedures." Texas Transportation Institute, Report 0-4703-7, Austin, TX.
- [12] Census of Fatal Occupational Injuries (2012). "Fatal occupational injuries by industry and selected event or exposure." U.S. Bureau of Labor Statistics, <<http://www.bls.gov/iif/oshwc/foi/cftb0259.pdf>> (Dec. 13, 2013).
- [13] Occupational Safety and Health Administration (2011). "OSHA injury and illness recordkeeping and reporting requirements." U.S. Bureau of Labor Statistics, <<https://www.osha.gov/recordkeeping>> (Aug. 14, 2013).
- [14] Census of Fatal Occupational Injuries (2013). "Fatal occupational injuries by industry and selected event or exposure." U.S. Bureau of Labor Statistics, <<http://www.bls.gov/iif/oshwc/foi/cftb0268.pdf>> (Dec. 12, 2013).
- [15] Occupational Safety and Health Administration. (2013). "Commonly used statistics." U.S. Bureau of Labor Statistics, <<http://www.osha.gov/oshstats/commonstats.html>> (Sep. 3, 2013).
- [16] Construction Industry Institute (2012). "2012 Safety Report." Construction Industry Institute, BMM2012-2, The University of Texas at Austin.
- [17] Bureau of Labor Statistics (2012). "Nonfatal occupational injuries and illnesses requiring days away from work, 2011." U.S. Department of Labor, <<http://www.bls.gov/news.release/osh2.nr0.htm>> (Nov. 10, 2013).
- [18] Bureau of Labor Statistics (2013). "Injuries, illnesses, and fatalities." U.S. Department of Labor, <<http://www.bls.gov/iif/oshsum.htm>> (Dec. 14, 2013).
- [19] Lindsay, F. (1992). "Successful health and safety management: The contribution of management audit." *Safety Science*, 15(1), 387-402.
- [20] Flin, R., Mearns, K., O'Connor, P., and Bryden, R. (2000). "Measuring safety climate: identifying the common features." *Safety science*, 34(1), 177-192.
- [21] United Kingdom Health and Safety Executive. (2012). "A guide to measuring health and safety performance." Health and Safety Executive, <<http://www.hse.gov.uk/opsunit/perfmeas.pdf>>. (May 6, 2013).

- [22] Hinze, J. (2006). Construction safety, Second edition, Prentice Hall, Gainesville, FL.
- [23] Construction Owners Association of Alberta (2004). "Leading indicator best practice." Construction Owners Association of Alberta, <<http://www.coaa.ab.ca/Portals/0/Downloads/BP%20Safety/LEADING%INDICATORS%20BEST%20PRACTICES.PDF>> (Feb. 26, 2013).
- [24] Fang, X. and Huang, H. (2004). "Factor analysis-based studies on construction workplace safety management in China." International Journal of Project Management, 22(1): 43-49.
- [25] Lingard, H. and Rowlinson, S. (1997). "Behavior-based safety management in Hong Kong's construction industry." Journal of Safety Research, 28(4), 243-256.
- [26] Choudhry, R., Fang, D., and Sherif Mohamed, S. (2007). "Developing a model of construction safety culture." Journal of Management in Engineering, 23(4), 207-212.
- [27] Zohar, D. and Luria, G. (2003). "The use of supervisory practices as leverage to improve safety behavior: A cross-level intervention model." Journal of Safety Research, 34(5), 567-577.
- [28] Occupational Safety and Health Administration, (2002). "Job hazard analysis." U.S. Bureau of Labor Statistics, <<http://www.osha.gov/Publications/osh3071.pdf>> (Nov. 6, 2013).
- [29] Rozenfeld, O., Sacks, R., Rosenfeld, Y., and Baum, H. (2010). "Construction job safety analysis." Safety Science 48(4), 491-498.
- [30] Agnew, J., and Daniels, A. (2011). "Development high-impact leading indicator for safety." The Performance Management Magazine, Accelerating Business Performance, <<http://aubreydaniels.com/pmezine/developing-high-impact-leading-indicators-safety>> (Oct. 18, 2013).
- [31] Jaselskis, E., Anderson, S., and Russell, J. (1996). "Strategies for achieving excellence in construction safety performance." Journal of Construction Engineering and Management, 122(1), 61-70.

- [32] Goldenhar, L., Moran, S., and Colligan, M. (2001). "Health and safety training in a sample of open-shop construction companies." *Journal of safety Research*, 32(2), 237-252.
- [33] Ho, C., and Dzung, R. (2010). "Construction safety training via E-Learning: Learning effectiveness and user satisfaction." *Computers & Education*, 55(1), 858-867.
- [34] Sullivan, A., and Sheffrin, S. (2003). *Economics: Principles in action*. Upper Saddle River, Pearson Prentice Hall. New Jersey.
- [35] Occupational Safety and Health Administration (2011). "Mission and Vision." U.S. Bureau of Labor Statistics, <<http://www.osha.gov/StratPlanPublic/strategicmanagementplan-final.html>> (Sep 10, 2011).
- [36] Overseas Shipholding Ground, Inc. (2009). "Near Miss Reporting Improvements." OSG Newsletter, <<http://www.osg.com/index.cfm?pageid=74&itemid=32>> (Aug. 16, 2013).
- [37] Toft, Y., Dell, G., Klockner, K., and Hutton, A. (2012). "Models of causation: Safety." *The Core body of knowledge for generalist OHS professionals*, Victoria, Australia.
- [38] Phimister, J., Oktem, U., Kleindorfer, P., and Kunreuther, H. (2003). "Near-Miss Incident Management in the Chemical Process Industry" *Risk Analysis*, 23(1), 445-459.
- [39] Hinze, J. (2002). "Safety plus: Making zero accidents a reality." *Construction Industry Institute*, 160-11, The University of Texas at Austin.
- [40] Huang, X. and Hinze, J. (2006). "Owner's role in construction safety." *Journal of Construction Engineering and Management*, 132(2), 164-173.
- [41] Hecker, S., Jambatese, J., and Weinstein, M. (2005). "Designing for worker safety: Moving the construction safety process upstream." *Professional Safety*, 23-44.
- [42] Hinze, J. and Wilson, G. (2000). "Moving toward a zero injury objective." *Journal of Construction Engineering and Management*, 126(5), 399-403.

- [43] Hallowell, M., Hinze, J., Baud, K., and Wehle, A. (2013). "Pro-Active construction safety control: Measuring, monitoring, and responding to safety leading indicators." *Journal of Construction Engineering and Management*, 139(10).
- [44] Hinze, J., Madariaga, M., and Pizarro, D. (2006). "Target safety: programs focused on preventing specific hazards." Construction Industry Institute, 216-11, The University of Texas at Austin.
- [45] Hinze, J. and Godfrey, R. (2003). "An evaluation of safety performance measures for construction projects," *Journal of Construction Research*, 4(1) 5-15.
- [46] Saurin, T., Formoso, C., Cambraia, F. (2008). "An analysis of construction safety best practices from a cognitive systems engineering perspective." *ScienceDirect, Elsevier*, 46(1), 1169-1183.
- [47] Cambraia, F., Saurin, T., Formoso, C. (2010). Identification, analysis and dissemination of information on near misses: A case study in the construction industry." *Safety Science, Elsevier*, 48(1), 91-99.
- [48] Census of Fatal Occupational Injuries (2013b). "Fatal occupational injuries by industry and selected event or exposure." U.S. Bureau of Labor Statistics, <<http://www.bls.gov/iif/oshcfoi1.htm#2011>> (Dec. 12, 2013).
- [49] Hinze, J. and Coates, W. (2011). "Trends in Construction Work Fatalities." Proceedings of CIB W099 Prevention: Means to the End of Injuries, Illnesses, and Fatalities. CIB World, Washington, DC, August 24.
- [50] Pegula, S. (2010). "Fatal occupational injuries at road construction sites, 2003-07." U.S. Bureau of Labor Statistics, <<http://www.bls.gov/opub/mlr/2010/11/art3exc.htm>> (Oct. 12, 2013).
- [51] Construction Industry Institute (2012). "2011 Safety Report." Construction Industry Institute, BMM2011-2, The University of Texas at Austin.
- [52] Center to Protect Workers' Rights (2013). *Leading causes of fatal and nonfatal injuries in construction, 5th Edition*, CPWR - The Center for Construction Research and Training, Silver Spring, Maryland.

- [53] Division of Occupational Safety and Health (2011). "Health hazards in construction." Washington State Department of Labor and Industries, <wishatraining.lni.wa.gov/training/presentations/HealthHaz.pps> (Aug. 23, 2013).
- [54] Rasche, T. (2009). "Bowtie analysis of vehicle collision accidents - a case for proximity detection and vehicle collision avoidance systems." Economic Development and Innovation, Queensland, Australia.
- [55] Pratt, S., Fosbroke, D., and Marsh, S. (2001). "Building Safer Highway Work Zones: Measures to Prevent Worker Injuries From Vehicles and Equipment," Department of Health and Human Services: CDC, Atlanta, GA.
- [56] Abdelhamid, T. and Everett, J. (2000). "Identifying root causes of construction accidents." *Journal of Construction Engineering and Management*, 126(1), 52-60.
- [57] Fosbroke, D.E. (2004). "NIOSH Reports! Studies on Heavy Equipment Blind Spots and Internal Traffic Control." NIOSH, <https://www.workzonesafety.org/files/documents/news_events/wz_conference_2004/heavy_equipment.pdf> (May 16, 2013).
- [58] Horberry, T., Larsson, T., Johnston, I., and Lambert, J. (2004). "Forklift safety, traffic engineering and intelligent transport systems: A case study." *Applied Ergonomics*, 35(6), 575-581.
- [59] Wu, W., Yang, H., Li, Q., and Chew, D. (2012). "An integrated information management model for proactive prevention of struck-by-falling-object accidents on construction sites." *Automation in Construction*, (in press).
- [60] Esmaili, B. and Hallowell, M. (2012). "Attribute-based risk model for measuring safety risk of struck-by accidents." *Proceeding in Construction Research Congress*, ASCE, West Lafayette, IN.
- [61] Fullerton, C., Allread, B., and Teizer, J. (2009). "Pro-Active Real-time Personnel Warning System." *Proceedings of the Construction Research Congress, CRC*, Seattle, Washington, 31-40.
- [62] Hinze, J., and Teizer, J. (2011). "Visibility-related fatalities related to construction equipment." *Safety Science*, 49(5), 709-718.

- [63] Caterpillar (2014). "Operator Visibility." Caterpillar, <<http://www.catminestarsystem.com/archives/tags/operator%20visibility>> (March 15, 2014).
- [64] Sawacha, E., Shamil, N., and Fong, D. (1999). "Factors affecting safety performance on construction sites." *International Journal of Project Management*, 17(5), 309-315.
- [65] Park, H., Thomas, S., and Tucker, R. (2005). "Benchmarking of construction productivity." *Journal of Construction Engineering and Management*, 131(7), 772-778.
- [66] Cox, R., Issa, R., and Ahrens, D. (2003). "Management's perception of key performance indicators for construction." *Journal of construction engineering and management*, 129(2), 142-151.
- [67] Abudayyeh, O., Fredericks, T., Butt, S., and Shaar, A. "An investigation of management's commitment to construction safety." *International Journal of Project Management*, 24(2), 167-174.
- [68] Teizer, J., Venugopal, M., and Walia, A. (2008). "Ultra Wideband for Automated Real-time Three-Dimensional Location Sensing for Workforce, Equipment, and Material Positioning and Tracking." *Transportation Research Record: Journal of the Transportation Research Board*, 208(1), 13-20.
- [69] Bernstein, H., Russo, M., Laquidara-Carr, D. (2013). *Safety Management in the Construction Industry: Identifying Risks and Reducing Accidents to Improve Site Productivity and Project ROI*. McGraw Hill, Bedford, MA.
- [70] Gillen, M., Baltz, D., Gassel, M., Kirsch, L., and Vaccaro, D. (2002). "Perceived safety climate, job demands, and coworker support among union and nonunion injured construction workers." *Journal of Safety Research*, 33(1), 33-51.
- [71] Toole, T. (2002). "Construction site safety roles." *Journal of Construction Engineering and Management*, 128(3), 203-211.
- [72] Transfield Worley Services (2008). "Integrating process safety into the santos EHS management system." 8th Annual Best Practice Forum, Gold Coast, Australia, March 9-11.

- [73] Construction Management Association of American (2009). "Construction Management Standards of Practice." Construction Management Association of America, McLean, VA.
- [74] Teo, E., Ling, F., and Chong, A. (2005). "Framework for project managers to manage construction safety." *International Journal of Project Management*, 23(4), 329-341.
- [75] Carter, G. and Smith, S. (2006). "Safety hazard identification on construction projects." *Journal of Construction Engineering and Management*, 132(2), 197-205.
- [76] Trethewy, R., Atkinson, M., and Falls, B. (2003). "Improved hazard identification for contractors in the construction industry." *Journal of Construction Research* 4(1), 71-85.
- [77] Burke, M. Salvador, R., Smith-Crowe, K., and Chan-Serafin, S. (2011). "The dread factor: How hazards and safety training influence learning and performance." *Journal of Applied Psychology*, 96(1), 46-70.
- [78] Dewlaney, K. and Hallowell, M. (2012). "Prevention through design and construction safety management strategies for high performance sustainable building construction." *Construction Management and Economics*, 30(2), 165-177.
- [79] Toole, T., Heckel, P., and Hallowell, M. (2013). "Policy development: A key factor for enabling PtD." *Journal of the American Society of Safety Engineers*, 58(1): 41-47.
- [80] Yang, H. and Yang, S. (2007). "RFID sensor network: Network architectures to integrate RFID, sensor and WSN," *Measurement and Control*, 40(2), 56-59.
- [81] Dennis, B. and Hawk, R. (2008). *Avoiding low probability, high impact events*, Price Waterhouse Coopers, Atlanta, GA.
- [82] Murray, G. (2012). "Serious Injury and Fatality Prevention." 2012 American Society of Safety Engineers Professional Development Conference, Denver, CO, June 3-4.
- [83] Hallowell, M. and Gambatese, J. (2009) "Construction safety risk mitigation." *Journal of Construction Engineering and Management*, 135(12), 1316-1323.

- [84] Gambatese, J.A. (2008). "Research issues in prevention through design." *Journal of Safety Research*, 39(2), 153-156.
- [85] Yi, K., and Langford, D. (2006). "Scheduling-based risk estimation and safety planning for construction projects." *Journal of Construction Engineering and Management* 132(6), 626-635.
- [86] Choudhry, R. and Fang, D. (2008). "Why operatives engage in unsafe work behavior: Investigation factors on construction sites." *Safety Science*, 46(4), 566-584.
- [87] Molenaar, K., Park, J., and Washington, S. (2009). "Framework for measuring corporate safety culture and its impact on construction safety performance." *Journal of Construction Engineering and Management*, 135(6), 488-496.
- [88] Gadd, S. and Collins, A. (2002). "Safety culture: A review of the literature." Health and Safety Laboratory, Human Factor Group, <http://www.hse.gov.uk/research/hsl_pdf/2002/hsl02-25.pdf > (Nov. 6, 2013).
- [89] Guldenmund, F. (2000). "The nature of safety culture: a review of theory and research." *Safety Science*, 34(1), 215-257.
- [90] Ian, G. and Stanton, N. (2000). "Perspectives on safety culture." *Safety Science*, 34(1), 193-214.
- [91] Jones, S., Kirchsteiger, C., Bjerke, W. (1999). "The importance of near miss reporting to further improve safety performance." *Journal of Loss Prevention in the Process Industries*, 12 (1), 59-67.
- [92] Reason, J. (1990). *Human Error*, Cambridge UP, New York.
- [93] Suraji, A., Duff, A., and Peckitt, S. (2001). "Development of causal model of construction accident causation." *Journal of Construction Engineering and Management*, 127(4), 337-345.
- [94] Phimister, J., Bier, R., and Kunreuther, H. (2004). "Accident precursor analysis and management: Reducing technological risk through diligence." National Academy Press, Washington, DC.

- [95] Phimister, J., Oktem, U., Kleindorfer, P., and Kunreuther, H. (2010). "Near-Miss System Analysis: Phase I." Wharton School, Center for Risk Management and Decision Processes, University of Pennsylvania.
- [96] Williamsen, M. (2012). "Near Miss Reporting: The Missing Link to Safety Culture Revolution," Caterpillar, Inc. Peoria, IL.
- [97] Ritwik, U. (2002). "Risk based approach to near misses." *Hydrocarbon Processing*, 81(1) 93-96.
- [98] Bechtel (2009). "Reporting and investigating near miss incidents." Bechtel Environmental Safety and Health, 2.
- [99] Durnwald, D. (2012). "Incident Investigating and Reporting Procedure - Major Incident Announcement." *British Petroleum Oil Refinery*, 3.
- [100] International Association of Fire Chiefs (2012). "Welcome to the National Fire Fighter Near-Miss Reporting System." National Fire Fighter Near-Miss Reporting System, <<http://www.firefighternearmiss.com/index.php/home>> (July 24, 2013).
- [101] Gyi, D., Gibb, A. and Haslam, R. (2010). "The Quality of Accident and Health Data in the Construction Industry: Interviews with Senior Managers," *Construction Management and Economics*, 17(2) 197-204.
- [102] Industrial Hygiene Metrics and Reporting Procedure (2004). "Health, Safety, and Environment - Incident Investigation Guide." *Conoco Phillips*, 3(1), 1-10.
- [103] Caterpillar (2013). "Object detection system." *Caterpillar*, <<http://www.cat.com/detect>> (Aug. 20, 2013).
- [104] Wu, W., Huanjia, Y., Chew, D., Yang, S., Gibb, A., and Li, Q. (2010). "Towards an Autonomous Real-Time Tracking System of Near-Miss Accidents on Construction Sites," *Automation in Construction*, Elsevier 19(1), 134-141.
- [105] Martin, S., Etchegaray, J., Simmons, D., Belt, W., and Clark, K. (2005). "Development and Implementation of The University of Texas Close Call Reporting System." Information for the Defense Community, 1-13.

- [106] Schaaf, T. and Kanse, L. (2004). "Biases in incident reporting databases: An empirical study in the chemical process industry," *Safety Science*, Elsevier, 42(1) 57-67.
- [107] Henneman, E. and Gawlinski, A. (2004). "A near-miss model for describing the nurse's role in the recovery of medical errors," *Journal of Professional Nursing*, 20(3) 196-201.
- [108] Lawton, R. and Parker, D. (2002). "Barriers to incident reporting in a healthcare system," *Quality and Safety in Healthcare*, 11(1) 15-18.
- [109] Callum, J., Kaplan, H., Merkley, L., Pinkerton, P., Fastman, B., Romans, R., Coovadia, A., and Reis, M. (2001). "Reporting of near-miss events for transfusion medicine: Improving transfusion safety," *Transfusion Practice*, 41(1), 1204-1211.
- [110] Wagner, L., Capezuti, E., and Ouslander, J. (2006). "Reporting near-miss events in nursing homes," *Nursing Outlook*, 54(1) 85-93.
- [111] Donovan, T. (2011). "U.S. Nuclear Power Plants 2010: UCS Report." *Huffington Post*, <http://www.huffingtonpost.com/2011/03/17/us-nuclear-power-near-misses-2010_n_837176.html#s254851&title=HB_Robinson> (May 16, 2013).
- [112] Clancy, P., Leva, M., Hrymak, V., Sherlock, M. (2011). "Safety and/or hazard near miss reporting in an international energy company," *Proceedings of the Irish Ergonomic Society Annual Conference*, Trinity College, Dublin, 1-9.
- [113] Lander, L., Eisen, E., Stentz, T., Spanjer, K., Wendland, B., and Perry, M. (2011). "Near-Miss reporting system as an occupational injury preventive intervention in manufacturing," *American Journal of Industrial Medicine*, 54(1) 40-48.
- [114] American Bureau of Shipping (2012). "Guidance notes on safety culture and leading Indicators of safety." *American Bureau of Shipping*, <http://www.eagle.org/eagleExternalPortalWEB/ShowProperty/BEA%Repository/Rules&Guides/Current/188_Safety/Guide> (Aug. 6, 2013).
- [115] Civil Aviation Authority. (2013). "Safety Management: Incident Reporting and Investigation." *Civil Aviation Authority*, <<http://www.caa.co.uk/default.aspx?catid=1779&pageid=9864>> (Mar. 20, 2013).

- [116] Fowler, F. (2009). Survey research methods. Vol. 1. Sage. Thousand Oaks, CA.
- [117] Crane, C., Armstrong, D., and Rankin, A. (1995). "Autonomous navigation of heavy construction equipment." *Computer Aided Civil and Infrastructure Engineering* 10(5), 357-370.
- [118] Lytle, A. and Saidi, K. (2007). "NIST research in autonomous construction." *Autonomous Robots* 22(3), 211-221.
- [119] Rosner, B. (2011). *Fundamentals of Biostatistics*, CengageBrain, Independence, KY.
- [120] Santos, J. (1999). "Cronbach's alpha: A tool for assessing the reliability of scales." *Journal of Extension*, 37(2), 1-5.
- [121] McKay, B. (2013). "Measures of Effect: Near Miss Reporting on Construction Site Injuries." Master's Thesis, The University of Alaska.
- [122] Rasmussen, J., (1982). "Human errors: taxonomy for describing human malfunction in industrial installations." *Journal of Occupational Accidents*, 4(1), 311-313.
- [123] Hinze, J., Pedersen, C., and Fredley, J. (1998). "Identifying root causes of construction injuries." *Journal of Construction Engineering and Management*, 124(1), 67-71.
- [124] International Organization for Standards (2011). "Earth-moving Machinery - Operator's Field of View." International Standard, Part 2: Evaluation Method, <http://www.iso.org/iso/catalogue_detail.htm?csnumber=45609> (Mar. 10, 2011).
- [125] International Organization for Standards (2009). "Earth-moving Machinery Field of Vision of Surveillance and Rear." International Standard, Part 1: Test Method, <http://www.iso.org/iso/iso_catalogue/catalogue_tc/catalogue_detail.htm?csnumber=44175> (Mar. 9, 2011).
- [126] Hefner, R. (2003). "Construction vehicle and equipment blind area diagrams." NIOSH, 200-2002-00563, Morgantown, WV.

- [127] Larue, C. and Giguère, D. (1992). "Measurement and evaluation of blind spots in trucks - Rear view of vehicles." IRSST, <http://www.irsst.qc.ca/en/_projet_2404.html#haut> (May 15, 2013).
- [128] Bostelman, R. (2011). "Measurement and evaluation of visibility experiments for powered industrial vehicles." National Institute of Standards and Technology, Gaithersburg, MD.
- [129] National Institute for Occupational Safety and Health (2011b). "Highway Work Zone Safety." Center for Disease Control and Prevention, <<http://www.cdc.gov/niosh/topics/highwayworkzones/BAD>> (Oct. 30, 2011).
- [130] Teizer, J., Allread B.S., Fullerton, C.E. and Hinze, J. (2010). "Autonomous Pro-Active Real-Time Construction Worker and Equipment Operator Proximity Safety Alert System." *Automation in Construction*, 19(5), 630-640.
- [131] Toole, M. (2002). "The relationship between employees' perceptions of safety and organizational culture." *Journal of Safety Research*, 33(2), 231-243.
- [132] Song, J., Haas, C., and Caldas, C. (2006). "Tracking the location of materials on construction job sites." *Journal of Construction Engineering and Management*, 132(9), 911-918.
- [133] Song, J., Haas, C., Caldas, C., Ergen, E., and Akinici, B. (2006). "Automating the task of tracking the delivery and receipt of fabricated pipe spools in industrial projects." *Automation in Construction*, 15(2), 166-177.
- [134] Akinici, B. and Anumba, C. (2008). "Editorial - Sensors in construction and infrastructure management." *ITcon, Special Issue Sensors in Construction and Infrastructure Management*, 13(1), 69-70.
- [135] Grau, D., Caldas, C., Haas, C., and Goodrum, P. (2009). "Assessing the impact of materials tracking technologies on construction craft productivity." *Automation in Construction*, 18(1), 903-911.
- [136] Love, P. and Zahir, I. (2004). "An exploratory study of information technology evaluation and benefits management practices of SMEs in the construction industry." *Information and Management*, 42(1), 227-242.

- [137] American National Standards Institute (2013). "ANSI - American National Standards Institute." ANSI, <http://global.ihc.com/standards.cfm?publisher=ANSI&RID=Z56&MID=5280&gclid=CMr-kJG08bsCFU5o7AodDAYAJw> (Oct. 10, 2013).
- [138] American Society of Safety Engineers (2013). "The American Society of Safety Engineers." ASSE, <www.asse.org> (Oct. 10, 2013).
- [139] Acumine (2013). "Acumine collision avoidance safety system - Mine proximity detection." Acumine, <<http://www.acumine.com>> (Oct. 18, 2013).
- [140] Avoidance System (2013). "Avoidance system CAS-CAM/FR – Mine proximity detection." Advanced Mining Technologies, <<http://www.advminingtech.com.au>> (Aug. 25, 2013).
- [141] Becker (2013). "Electronics collision avoidance system - Mine proximity detection." Becker, <<http://www.za.becker-mining.com>> (Jun. 23, 2013).
- [142] Modular Mining Systems, Inc. (2013). "Roadmap Proximity Detection." Modular Mining Systems, Inc., <<http://www.mmsi.com>> (Feb. 12, 2013).
- [143] Salvador, C., Zani, F., and Gentili, B. (2011). "RFID and sensor network technologies for safety managing in hazardous environments." 2011 IEEE International Conference: RFID-Technologies and Applications, Athens, Greece.
- [144] National Institute of Occupational Safety and Health (2007). "Recommendations for Evaluating & Implementing Proximity Warning Systems on Surface Mining Equipment." Department of Health and Human Services: CDC, RI 9672, Atlanta, GA.
- [145] Buchsbaum, L. (2011). "Ready or not, MSHA believes proximity detection can save lives." *Coal Age*, 116(2), 37-38.
- [146] Lonmer, R. (2009). "Collision Avoidance in the Mining Industry." *GPS World*, 7(1), 1-2.
- [147] Occupational Safety and Health Administration (2013). "Occupational Safety and Health Administration." U.S. Department of Labor, <<https://www.osha.gov>> (Dec. 10, 2013).

- [148] Occupational Safety and Health Administration. (2013c). "Personal Protective Equipment (PPE)." OSHA, <<https://www.osha.gov/SLTC/personalprotectiveequipment/>> (Sep. 5, 2013).
- [149] Duchon and Laage (2011). "The Consideration of Human Factors in the Design of a Backing-up Warning System." Human Factors and Ergonomics Society Annual Meeting Proceedings, <<http://www.ingentaconnect.com/content/hfes/hfproc/1986/00000030/00000003/art00014>> (Sep 19, 2013).
- [150] Creative Solutions (2011). "Workers who operate within traffic and work zones may be exposed to noise." Hazard Analysis, <http://cpwrconstructionsolutions.org/heavy_equipment/hazard/1078/operate-within-traffic-and-work-zones-noise.html> (Sep 25, 2013).
- [151] Macmillian, N. (2002). Signal detection theory: Stevens' handbook of experimental psychology, Wiley, New York.
- [152] Navon, R. and Sacks R. (2006). "Assessing research issues in automated project performance control (APPC)." Automation in Construction, 16(4), 474-484.
- [153] Hinze, J. and Gambatese J. (1996). "Addressing Construction Worker Safety in the Project Design." Construction Industry Institute, RR101-11, The University of Texas at Austin.
- [154] Teizer, J., Caldas, C.H., and Haas, C.T. (2007). "Real-Time Three-Dimensional Occupancy Grid Modeling for the Detection and Tracking of Construction Resources." ASCE Journal of Construction Engineering and Management, 133(11), 880-888.
- [155] Chi, S., Caldas, C., and Gong, J. (2008). "A Crash Avoidance Framework for Heavy Equipment Control Systems Using 3D Imaging Sensors." ITCon Special Issue on Sensors in Construction and Infrastructure Management, 13(1), 118-133.
- [156] Chirdon, D. (2009). "MSHA Proximity Detection." Mine Safety and Health Administration Report, 1-11.
- [157] Ruff, T.M. (2010). "Overview of proximity warning technology and approaches." NIOSH Workshop on Proximity Warning Systems for Mining Equipment, Charleston, WV.

- [158] Pradhananga, N. and Teizer, J. (2013). "Automatic spatio-temporal analysis of construction site equipment operations using GPS data," *Automation in Construction*, 29(1), 107-122.
- [159] Wintec. (2010). "Wintec bluetooth GPS receiver with micro interface user's manual." Wintec Co., Ltd., Taiwan.
- [160] Ergen, E., Akinci, B., and Sacks, R. (2007). "Tracking and locating components in a precast storage yard utilizing radio frequency identification technology and GPS," *Automation in Construction*, 16 (3), 354-367.
- [161] Grau, D. and Caldas, C. (2009) "A methodology for automating the identification and localization of construction components on industrial projects." *Journal of Computing in Civil Engineering*, 23(1), 3-13.
- [162] Nasir, H., Haas, C., Young, D., Razavi, S., Caldas, C., and Goodrum, P. (2010). "An implementation model for automated construction materials tracking and locating." *Canadian Journal of Civil Engineering*, 37(4), 588-599.
- [163] Ruff, T. (2007). "Recommendations for evaluating and implementing proximity warning systems on surface mining equipment". NIOSH, <<http://www.cdc.gov/niosh/mining/pubs/pubreference/outputid2480.htm>> (Dec 1, 2013).
- [164] EMESRT (2013). "Earth Moving Equipment Safety Roundtable." EMESRT, <<http://www.emesrt.org>> (Sep. 2, 2013).
- [165] Schiffbauer, W.H. (2001). "An active proximity warning system for surface and underground mining applications", NIOSH, Report 20021434. Pittsburg, PA.
- [166] Schiffbauer, W. and Mowrey, G. (2008). "An environmentally robust proximity warning system for surface and underground mining applications", National Institute of Safety and Health, <<http://www.cdc.gov/niosh/mining/topics/machinesafety/equipmentdsgn/hasardsystem.htm>> (Nov. 20, 2013).
- [167] Strata Worldwide (2013). "Hazard alert." Strata Worldwide, <<http://www.strataworldwide.com/electronic-safety/hazardavert>> (Dec. 2, 2013).

- [168] Matrix M3 (2013). "Matrix M3 Proximity Detection - Underground Proximity Detection." Matrix Design Group, <<http://www.matrixteam.com>> (Nov. 10, 2013).
- [169] Nautilus International (2013). "International Coal Buddy System - Underground Coal Mines Proximity Detection." Nautilus International, <www.nautilus-intl.com> (Dec. 3, 2013).
- [170] Kochevar, K. (2007). "Intrusion devices - New and emerging technology in worker safety." The National Work Zone Safety Information Clearinghouse, <http://ops.fhwa.dot.gov/wz/workshops/originals/Ken_Kochevar_ID.ppt#256,1>, Intrusion Devices - New and Emerging Technology in Worker Safety> (Aug. 31, 2013).
- [171] 3D-P Inc. (2009). "Reliable wireless networks." 3D-P Technology Connected, <<http://www.3d-p.com>> (Dec. 2, 2013).
- [172] National Highway Traffic Safety Administration (2008). "Development of a performance specification for camera/video imaging systems on heavy vehicles." NHTSA, DOT HS 810 958, Washington, D.C.
- [173] Ruff, T. (2004). "Advances in proximity detection technologies for surface mining." Proceeding of the 24th Annual Institute on Mining Health, Salt Lake City, UT.
- [174] Abeid, J., and Aditi, D. (2002). Time-Lapse digital photography applied to project management'." Journal of Construction Engineering and Management, 128(6), 530-535.
- [175] Cordova, F. and Brilakis, I. (2008). On Site 3D Vision Tracking of Construction Personnel. 16th Annual Conference of the International Group for Lean Construction, Manchester, UK. Oct. 22.
- [176] Bohn, J., and Teizer, J. (2009). "Benefits and barriers of construction project monitoring using hi-resolution automated cameras." Journal of Construction Engineering and Management, 136(6), 632-604.
- [177] Khoury, H. and Kamat, V. (2009). "Evaluation of position tracking technologies for user localization in indoor construction environments." Automation in Construction, 18(4), 444-457.

- [178] Teizer, J. and Vela, P. (2009). "Workforce tracking on construction sites using video cameras." *Advanced Engineering Informatics*, 23(4), 452-462.
- [179] Memarzadeh, M., Mani Golparvar-Fard, M., and Niebles, J. (2013). "Automated 2D detection of construction equipment and workers from site video streams using histograms of oriented gradients and colors." *Automation in Construction*, (in press).
- [180] Yang, H., Chew, D., Weiwei, W., Zhipeng, Z., and Qiming, Li. (2012). "Design and implementation of an identification system in construction site safety for proactive accident prevention." *Accident Analysis & Prevention*, 48(1), 193-203.
- [181] Kelm, A., Laußat, L., Meins-Becker, A., Platz, D., Khazae, M., Costin, A., Manfred Helmus, M., and Teizer, J. (2013). "Mobile passive Radio Frequency Identification (RFID) portal for automated and rapid control of Personal Protective Equipment (PPE) on construction sites." *Automation in Construction*, 36(1), 38-52.
- [182] Vilant (2013). "Vilant Systems." Vilant, <<http://www.vilant.com>> (Nov. 20, 2013).
- [183] EV Alert, (2008). "Forklift Tracking Safety." EV Alert, <www.evalert.com.au> (Nov. 10,2013).
- [184] Topping, R. (2012). "RFID for access control on construction sites." Fiatch, Austin, TX.
- [185] Costin, A., Pradhananga, N., & Teizer, J. (2012). "Leveraging passive RFID technology for construction resource field mobility and status monitoring in a high-rise renovation project." *Automation in Construction*, 24(1), 1-15.
- [186] MyZone (2013). "MyZone Worker Alert System." MyZone, <<http://www.myzoneglobal.com/contact.php>> (Nov. 3, 2013).
- [187] Worcester Polytechnic Institute (2009). "Precision indoor/outdoor personnel location project." Worcester Polytechnic Institute, <<http://www.wpi.edu/academics/ece/ppl>> (Aug 25, 2013).

- [188] Forklift Action (2006). "EV Alert - New cost effective safety systems for forklifts and other heavy vehicles." EV Alert, <<http://www.forkliftaction.com/news/newsdisplay.aspx?nwid=2852>> (Oct. 24, 2013).
- [189] Orbit (2010). "BodyGuard – Simply keeping a safe distance where it matters most." Orbit, <<http://www.orbitcoms.com>> (Nov. 10, 2013).
- [190] Protran Technology (2013). "Advanced Warning Devices." Protran, <<http://www.protrantechology.com>> (Sept. 5, 2013).
- [191] Swedberg, C. (2012). "At Edmonton's aggregate-recycling facilities, RFID provides an extra eye." RFID Journal, <<http://www.rfidjournal.com/articles/view?9720>> (Dec. 10, 2013).
- [192] Ruff, T. (2004). "Advances in proximity detection technologies for surface mining." Proceeding of the 24th Annual Institute on Mining Health, Salt Lake City, UT.
- [193] Frimpong, S., Li, Y., and Aouad, N. (2009). "Intelligent Machine Monitoring and Sensing for Safe Surface Mining Operations." *Appropriate Technologies for Environmental Protection in the Developing World*, Springer, Netherlands, 217-227.
- [194] Faul, H. and Belle, B. (2007). "Collision Avoidance: Matrix of Technologies." *ATD Mining Engineering, CAS-02*, Johannesburg, Republic of South Africa.
- [195] Saidi, K., Teizer, J., Franaszek, M., and Lytle, A. (2010). "Understanding static and dynamic localization performance of commercially-available ultra wideband tracking systems." *Automation in Construction*, 20(5), 519-530.
- [196] Fontana, R., Ameti, A., Richley, E., Beard, L., and Guy, D. (2002). "Recent advances in ultra wideband communications systems." *IEEE Conference on Ultra Wideband Systems and Technologies*, IEEE, 129-133.
- [197] Fontana, R., Richley, E., and Barney, J. (2003). "Commercialization of an ultra wideband precision asset location system." *IEEE Conference on Ultra Wideband Systems and Technologies*, IEEE, 369-373.

- [198] Fontana, R. (2004). "Recent system applications of short-pulse Ultra-Wideband (UWB) technology." *IEEE Transactions on Microwave Theory and Techniques*, 52(9), 2087-2104.
- [199] National Institute of Occupational Safety and Health (2010). "Preventing Injuries and Deaths from Skid Steer Loaders." Department of Health and Human Services: CDC, Atlanta, GA, 128.
- [200] National Institute of Occupational Safety and Health (2011). "Fatality Assessment and Control Evaluation (FACE) Program." Center for Disease Control and Prevention, <<http://www.cdc.gov/niosh/face>> (Nov. 15, 2013).
- [201] National Institute for Occupational Safety and Health (2011). "Highway Work Zone Safety." Center for Disease Control and Prevention, <<http://www.cdc.gov/niosh/topics/highwayworkzones/BAD>> (May 2, 2013).
- [202] Smith, D.W. (2005). "Skid Steer Loader Safety." *Agri-Life Extension*, The Texas A&M University System, 355(1). 1-3.
- [203] Teizer, J., B.S. Allread, and U. Mantripragada (2010b). "Automating the Blind Spot Measurement of Construction Equipment." *Automation in Construction*, 19(4), 491-501.
- [204] Ogle, K.N. (1950). *Research in Binocular Vision*, Hafner Publishing Company, New York.
- [205] Ruff, T.M. (2005). "Evaluation of a radar-based proximity warning system for off-highway dump trucks." *Accident Analysis & Prevention*, 38(1), 92-98.
- [206] Steele, J., Debrunner C., Whitehorn, M. (2003). "Stereo images for object detection in surface mine safety applications." Western Mining Resource Center, Report TR20030109, Colorado School of Mines.
- [207] Knoblauch, R., Pietrucha, M., and Nitzburg, M. (1996). "Field studies of pedestrian walking speed and start-up time." *Transportation Research Record*, 1538(1), 27-38.

- [208] Goodrum, P., McLaren, M., and Durfee, A. (2006). "The application of active radio frequency identification technology for tool tracking on construction job sites." *Automation in Construction*, 15(3), 292-302.
- [209] Kim, C., Haas, C., Liapi, K., and Caldas, C. (2006). "Human-assisted Obstacle Avoidance System Using 3D Workspace Modeling for Construction Equipment Operation." *Journal of Computing in Civil Engineering*, 20(3), 177-186.
- [210] Begley, R. (2006). "Development of autonomous railcar tracking technology using railroad industry radio frequencies: Research opportunities in radio frequency identification transportation applications. *Transportation Research Circular*, 59-60.
- [211] Larsson, T. (2003). "Industrial Forklift Trucks: Dynamic Stability and the Design of Safe Logistics." *Safety Science Monitor*, 7(1), 1-14.
- [212] Lázaro, A., Girbau, D., and Salinas, D. (2009). "Radio link budgets for UHF RFID on multipath environments." *Antennas and Propagation IEEE Transactions*, 57(4), 1241-1251.
- [213] Castleford, D., Nirmalathas, A., Novak, D., and Tucker, R. (2001). "Optical crosstalk in fiber-radio WDM networks: Microwave theory and techniques." *IEEE Transactions*, 49(10), 2030-2035.
- [214] Hallowell, M., Teizer, J., and Blaney, W. (2010). "Application of Sensing Technology to Safety Management." *Proceedings of the Construction Research Congress*, ASCE, Alberta, Canada. 31-40.
- [215] World Health Organization. (2012). "Electromagnetic fields and public health: Extremely low frequency (ELF) fact sheet 205." World Health Organization, <<http://www.who.int/mediacentre/factsheets/en/>> (June 2, 2013).
- [216] Caruso, M., Bratland, T., Smith, C., and Schneider, R. (1998). "A new perspective on magnetic field sensing." *SENSORS-PETERBOROUGH*, 15(1), 34-47.
- [217] Hit-Not (2013). "Hit-Not Proximity Detection." Hit-Not, <<http://www.hitnot.com>> (Jan. 3, 2013).

- [218] Schantz, H. (2007). "A real-time location system using near-field electromagnetic ranging." *Antennas and Propagation Society International Symposium IEEE*, 3792-3795.
- [219] Li, J., Carr, J., and Jobes, C. (2012). "A shell-based magnetic field model for magnetic proximity detection systems." *Safety Science*, 50(3) 463-471.
- [220] Carr, J., Jobes, C., Li, J. (2010). "Development of a method to determine operator location using electromagnetic proximity detection." 2010 IEEE International Workshop, Robotic and Sensors Environments (ROSE), Cool Spring Harbor, NY, 1-6.
- [221] Zhang, B., Zhang, J., Zhang, K., and Zhou, Z. (2007). "A non-contact proximity sensor with low frequency electromagnetic field." *Sensors and Actuators A: Physical*, 135(1) 162-168.
- [222] Griffin, J. and Durgin, G. (2008). "Gains for RF tags using multiple antennas." *Antennas and Propagation, IEEE Transactions*, 56(2), 563-570.
- [223] Ray, S., and Teizer, J. (2013). "Computing 3D Blind Spots of Construction Equipment: Implementation and Evaluation of an Automated Measurement and Visualization Method Utilizing Range Point Cloud Data", *Automation in Construction*, 36(1), 95-107.

VITA

Eric Marks

Eric Marks received a Bachelor's and Master's degree in Civil Engineering with an emphasis in construction management at the University of Kentucky. He also received a minor in mathematics from the University of Kentucky. Eric worked as a staff engineer for the Kentucky Department of Transportation for 4 years and obtained his Professional Engineer's (PE) licensure from the State of Kentucky. As a staff engineer for the Kentucky Department of Transportation, Eric solved design errors in the field, created project estimates, developed project contracts, developed and supervised construction projects and inspected highway and bridge construction projects. Eric also supervised, organized and educated highway construction inspectors and maintenance workers. His current research areas include pro-active construction safety, measuring and analyzing safety leading indicators, and real-time sensing technology for construction applications. Eric's research aims to enhance construction safety by allowing for additional performance metrics and providing real-time decision making for construction site personnel. His research was recognized by the Construction Research Council and the Construction Industry Institute, two of the largest research organizations of construction engineering and management in North America. By the time of his graduation, Eric's research findings will have been presented in multiple journal publications and conference proceedings. Eric has joined the Department of Civil, Construction, and Environmental Engineering at the University of Alabama as an assistant professor.