

(12) United States Patent
Brady et al.

(10) Patent No.: US 7,034,603 B2
(45) Date of Patent: Apr. 25, 2006

(54) **FLOATING-GATE REFERENCE CIRCUIT**

6,366,519 B1 4/2002 Hung et al. 365/226

(75) Inventors: **Philomena Cleopha Brady**, Garland, TX (US); **Haw-Jing Lo**, Atlanta, GA (US); **Guillermo José Serrano**, Atlanta, GA (US); **Farhan Adil**, Silver Springs, MD (US); **Matthew Raymond Kucic**, Austell, GA (US); **Paul Edward Hasler**, Atlanta, GA (US); **David V. Anderson**, Alpharetta, GA (US); **Angelo W. Pereira**, Atlanta, GA (US)

(73) Assignee: **Georgia Tech Research Corporation**, Atlanta, GA (US)

(*) Notice: Subject to any disclaimer, the term of this patent is extended or adjusted under 35 U.S.C. 154(b) by 0 days.

(21) Appl. No.: **10/446,087**

(22) Filed: **May 27, 2003**

(65) **Prior Publication Data**
 US 2004/0240278 A1 Dec. 2, 2004

(51) **Int. Cl.**
G05F 1/10 (2006.01)
 (52) **U.S. Cl.** **327/538**
 (58) **Field of Classification Search** **327/530, 327/534, 535, 537, 538, 540, 541, 543**
 See application file for complete search history.

(56) **References Cited**
 U.S. PATENT DOCUMENTS

6,014,044 A * 1/2000 Kramer et al. 327/81
 6,175,521 B1 1/2001 Pascucci et al. 365/185.18

OTHER PUBLICATIONS

Guillermo Serrano, Matt Kucic, Paul Hasler, "Investigating Programmable Floating-Gate Digital-to-Analog Converter as Single Element or Element Arrays," Ga. Inst. of Technology, Dept. of Electrical and Computer Eng., pp. 1-3.
 Angelo Pereira, Philomena Brady, Abishek Bandyopadhyay, Paul E. Hasler, "Experimental Investigations of Floating-Gate Circuits for Modulators," Dept. of Electrical and Computer Eng., Ga. Inst. of Technology, pp. I-208-I-210.
 Philomena Brady, Paul Hasler, "Investigations Using Floating-Gate Circuits for Flash ADCS," Ga. Inst. of Technology, Dept. of Electrical and Computer Engineering, pp. II-83-II-86.

* cited by examiner

Primary Examiner—Jeffrey Zweizig

(74) *Attorney, Agent, or Firm*—Thomas, Kayden, Horstemeyer & Risley, LLP

(57) **ABSTRACT**

Systems and methods are discussed for using a floating-gate MOSFET as a programmable reference circuit. One example of the programmable reference circuit is a programmable voltage reference source, while a second example of a programmable reference circuit is a programmable reference current source. The programmable voltage reference source and/or the reference current source may be incorporated into several types of circuits, such as comparator circuits, current-mirror circuits, and converter circuits. Comparator circuits and current-mirror circuits are often incorporated into circuits such as converter circuits. Converter circuits include analog-to-digital converters and digital-to-analog converters.

27 Claims, 9 Drawing Sheets

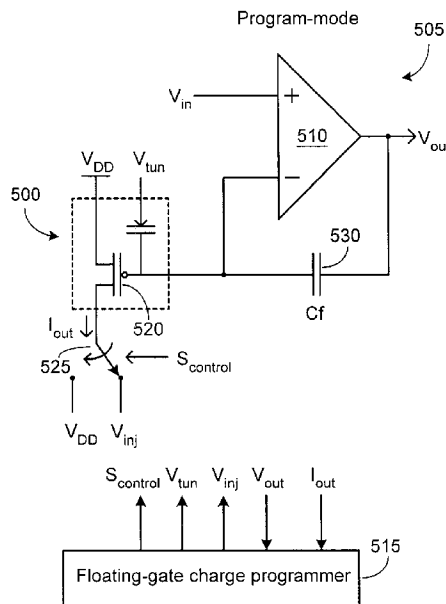

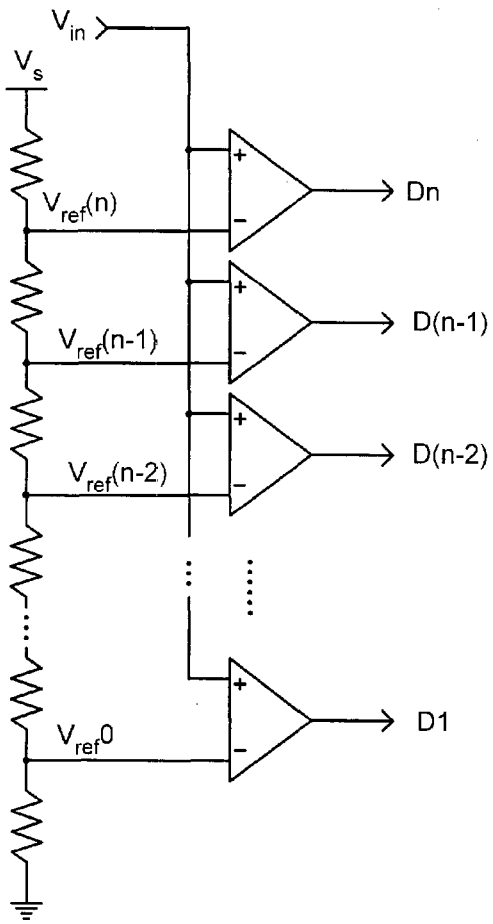

FIG. 1
(Prior Art)

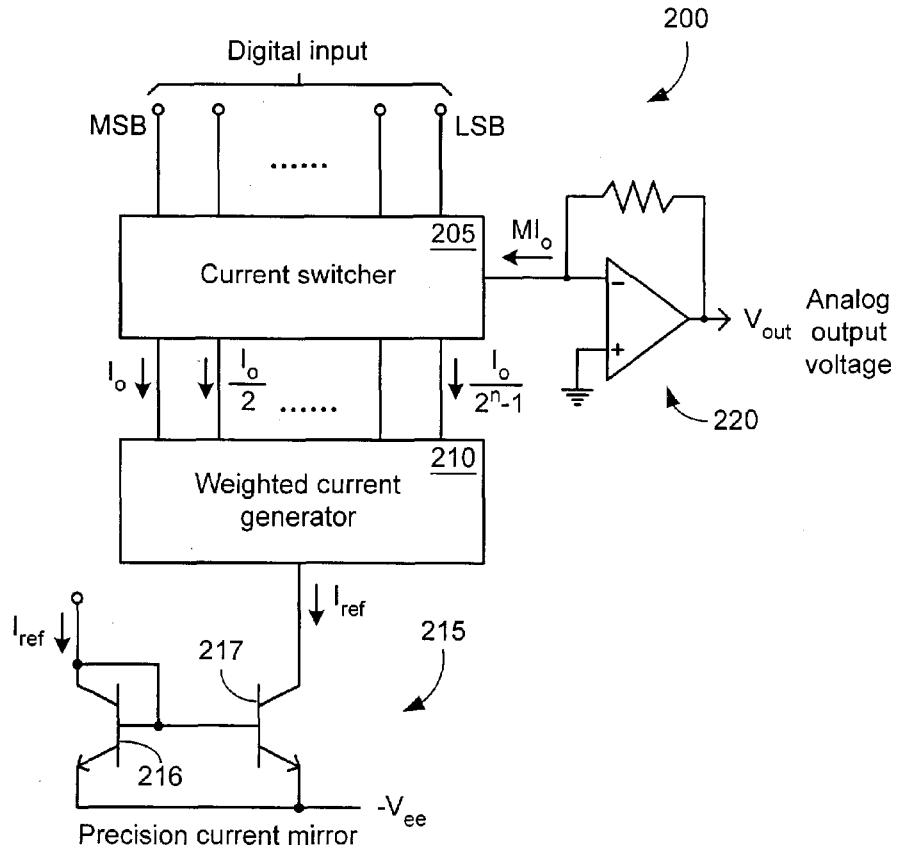

FIG. 2
(Prior Art)

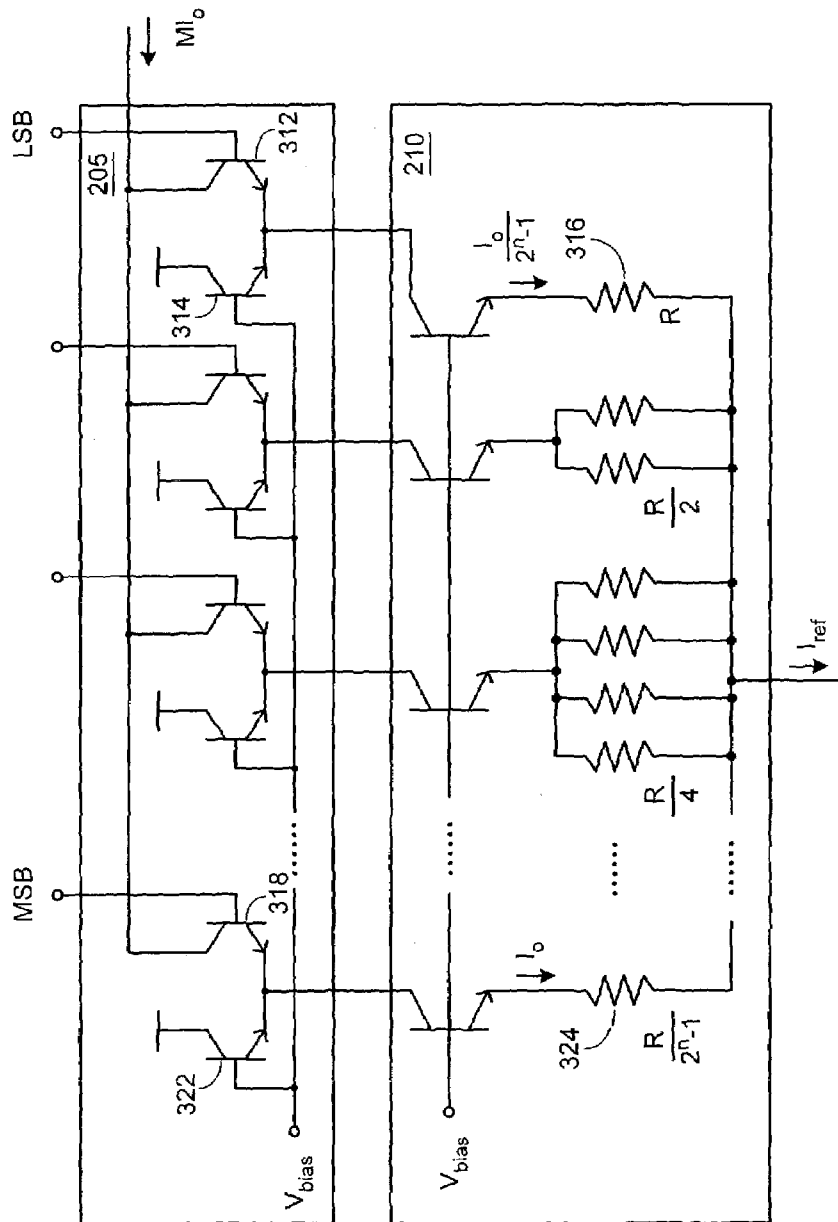

FIG. 3
(Prior Art)

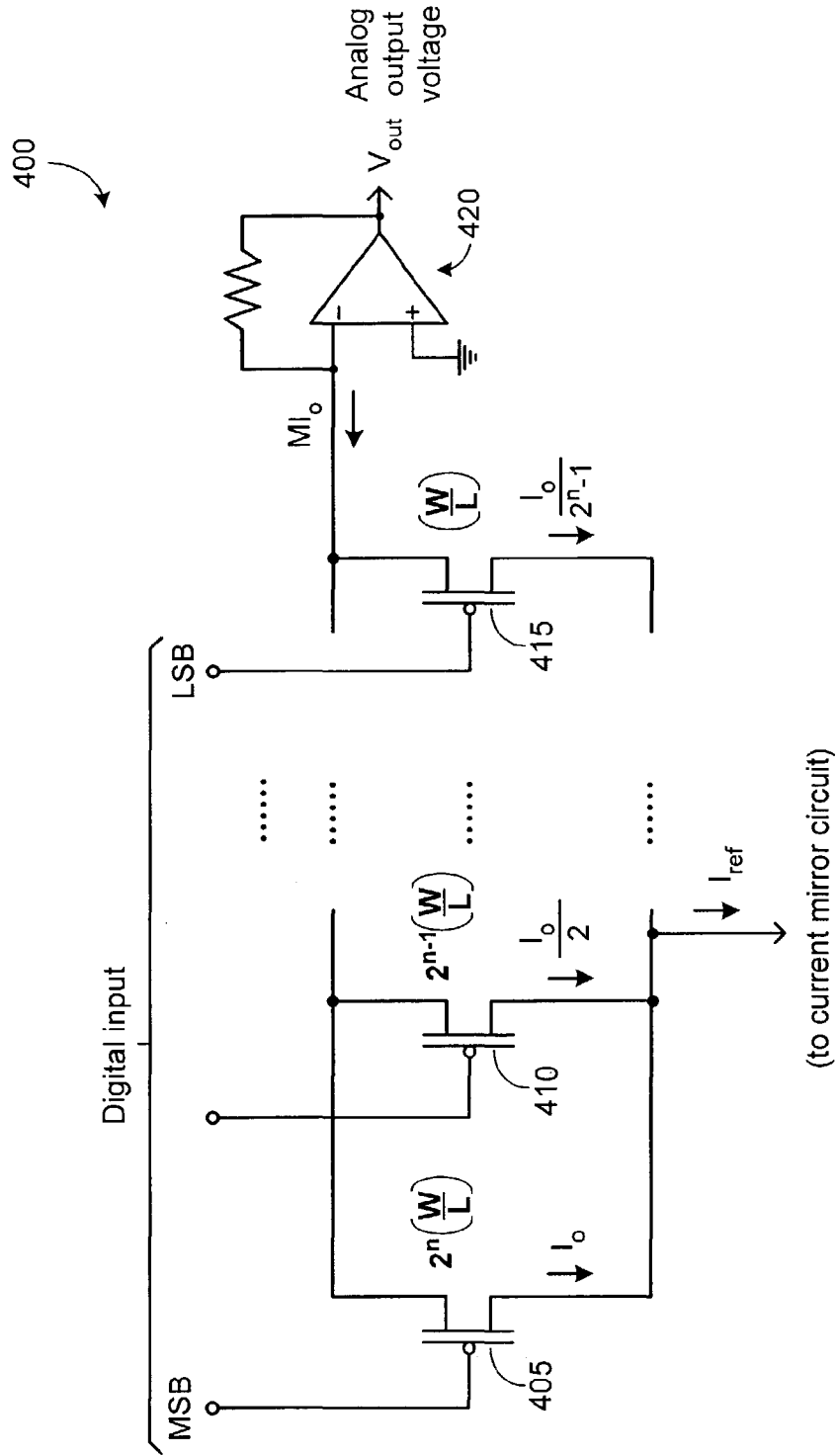

FIG. 4
(Prior Art)

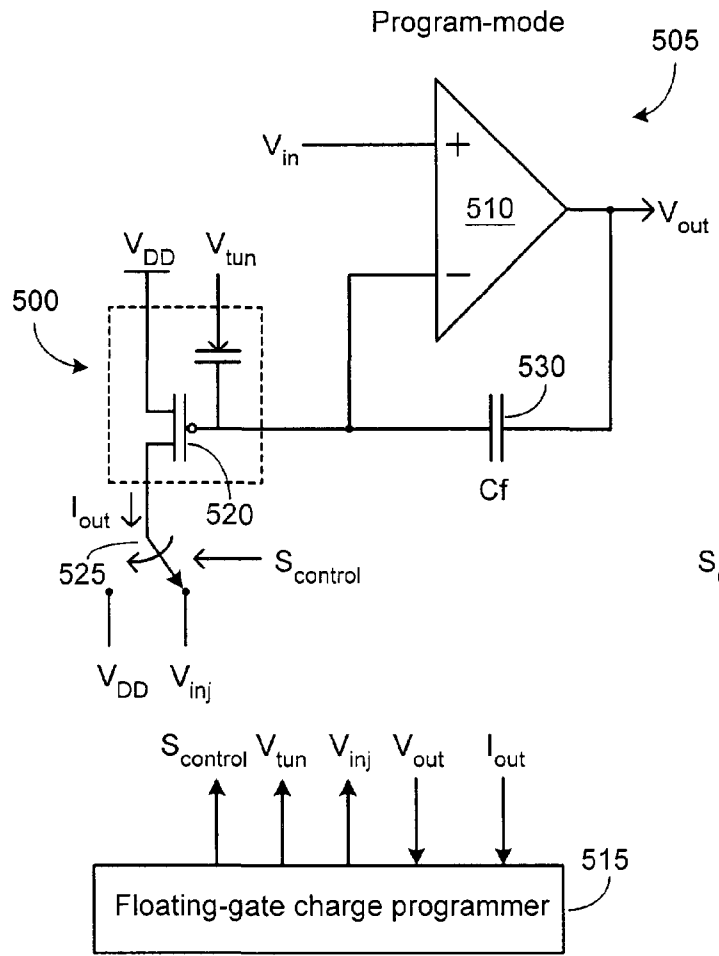

FIG. 5

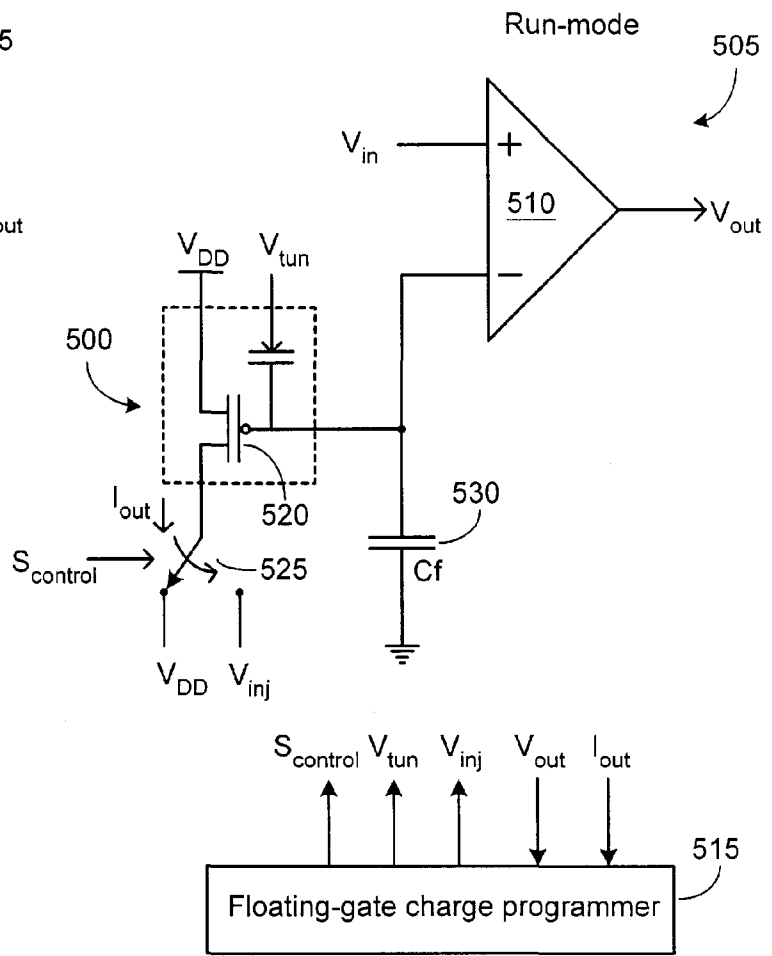

FIG. 6

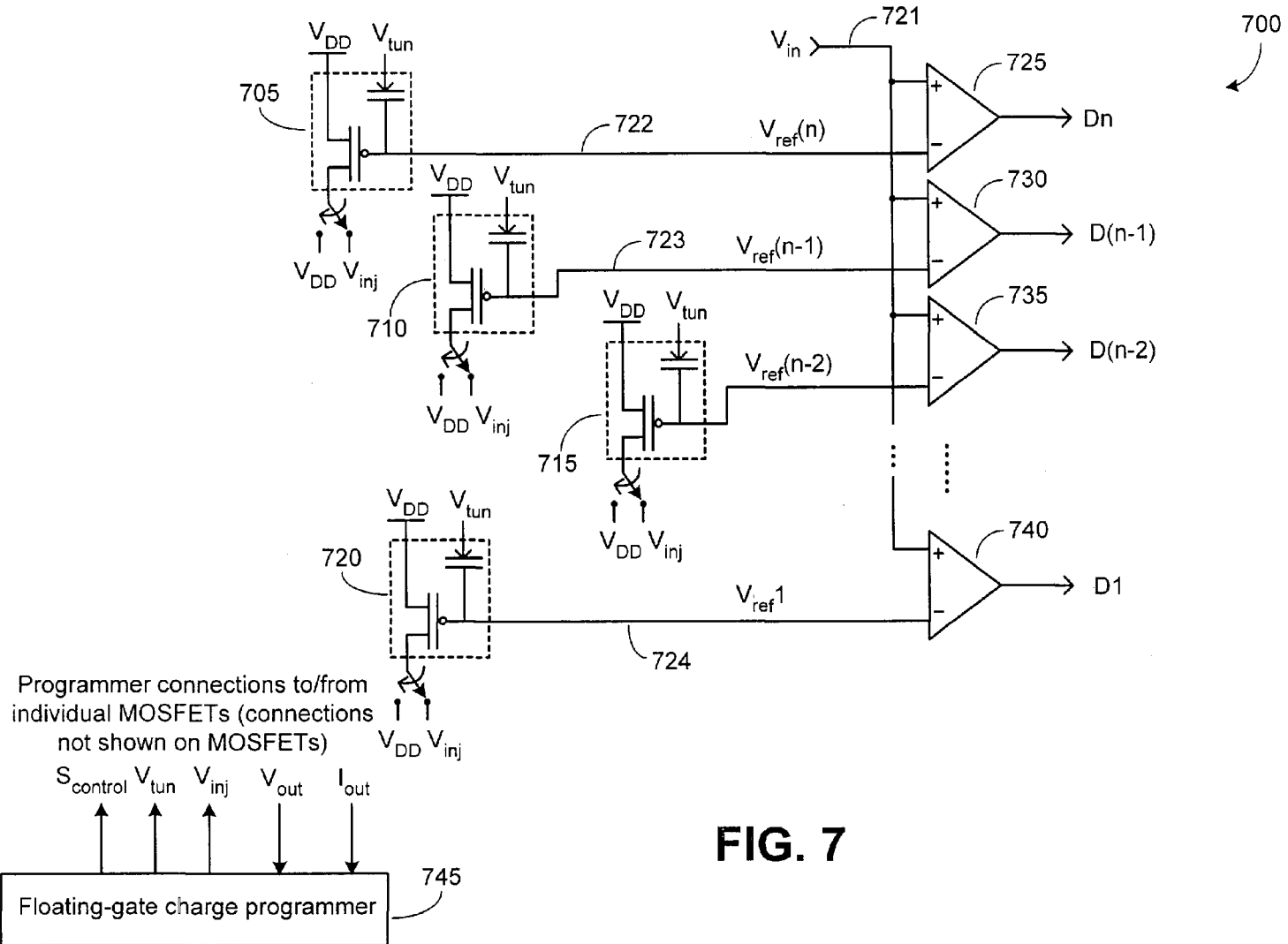

FIG. 7

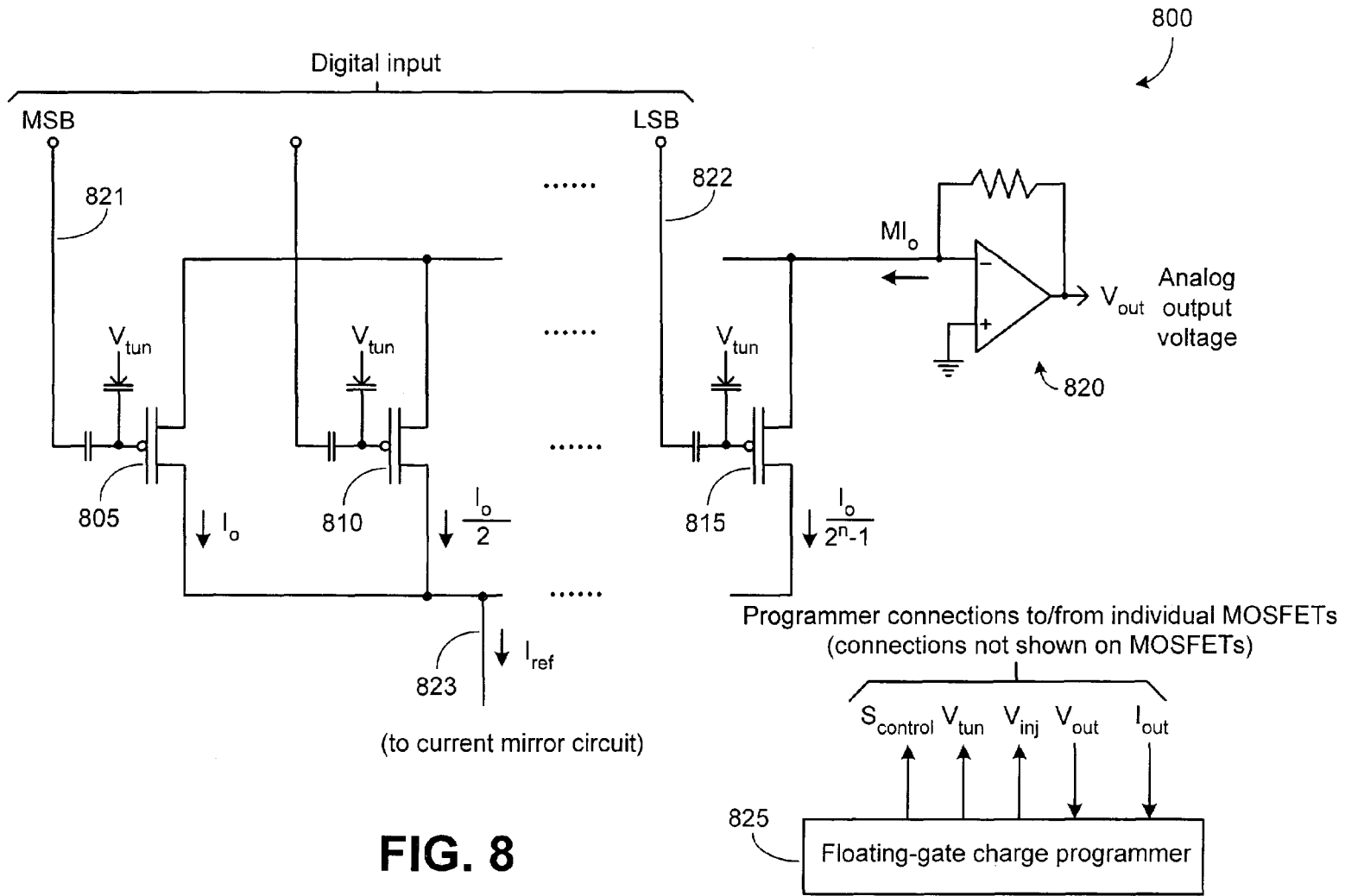

FIG. 8

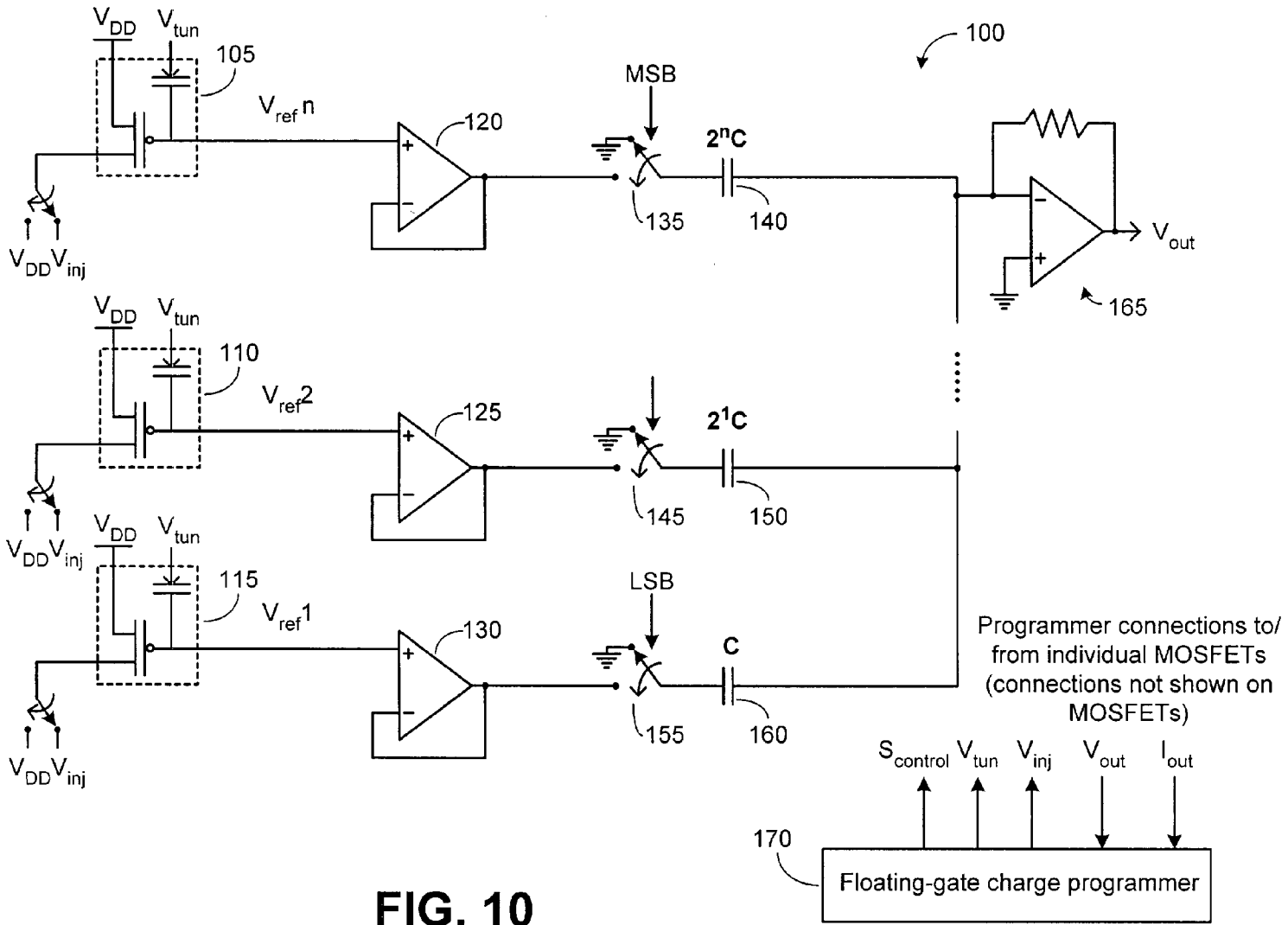

FIG. 10

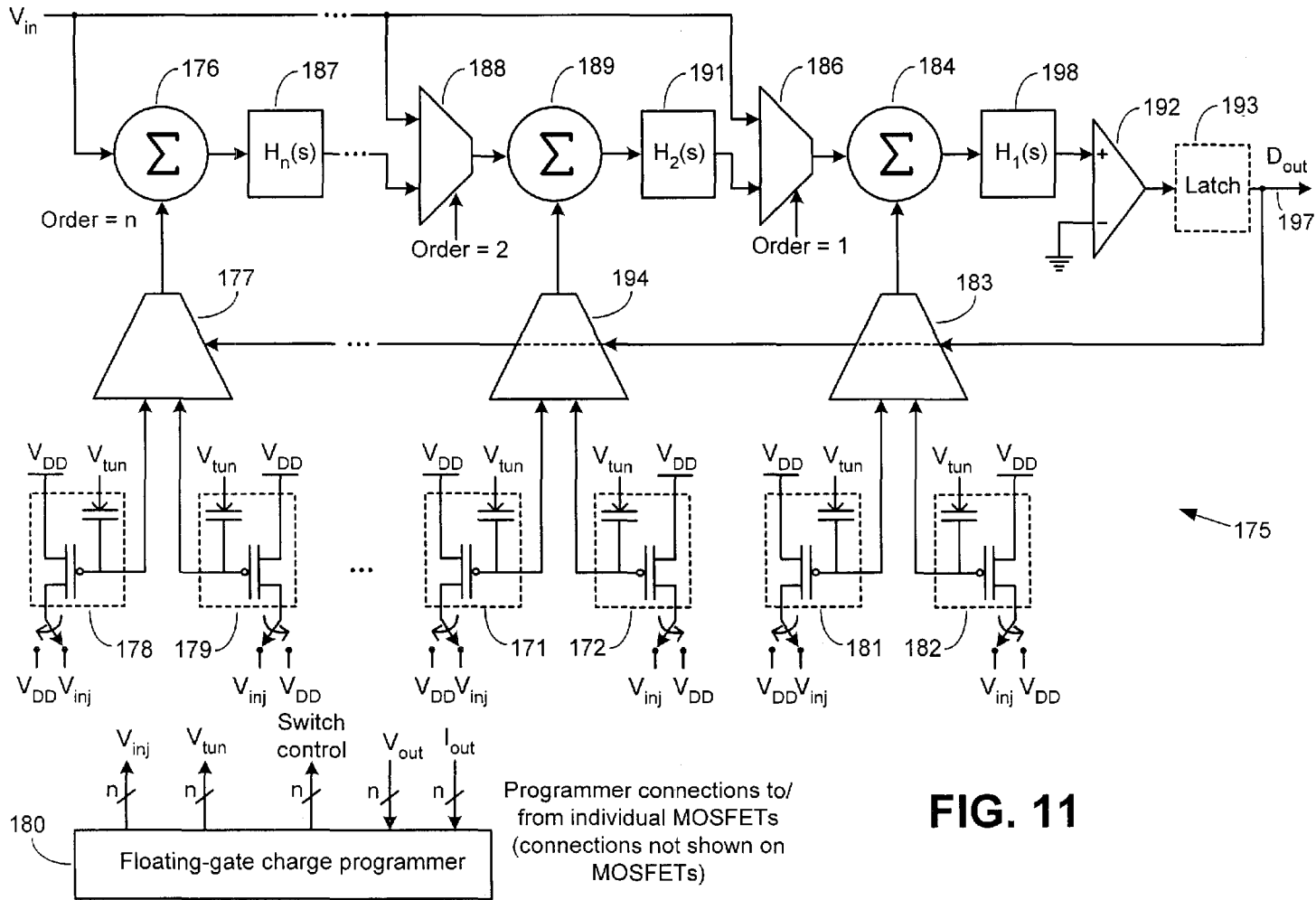

FIG. 11

1

FLOATING-GATE REFERENCE CIRCUIT

STATEMENT REGARDING FEDERALLY SPONSORED RESEARCH OR DEVELOPMENT

The U.S. government may have a paid-up license in this invention and the right in limited circumstances to require the patent owner to license others on reasonable terms as provided for by the terms of Grant No. EIA-0083172 awarded by the National Science Foundation of the U.S.

TECHNICAL FIELD

The present invention generally relates to the field of voltage and/or current reference circuits. More specifically it relates to a floating gate field-effect transistor that can be programmed as a voltage/current reference.

BACKGROUND OF THE INVENTION

Two classes of reference circuits that are used in electronic circuits may be generally referred to as "reference voltage nodes" and "reference current sources." A fixed-value reference voltage node can be created by using fixed-value discrete resistors configured in a resistive divider circuit. The accuracy of the reference voltage created by such a resistive divider circuit is determined by the accuracy of the fixed-value resistors and the accuracy of the voltage source(s) connected to the resistors. The accuracy of a fixed-value resistor is typically defined by a tolerance parameter that specifies the allowable variation of resistance from a nominal resistance value. For example, a 100 ohm, 10% resistor may be used in a circuit that permits a variation in resistance between 90 and 110 ohms, while a 100 ohm, 1% resistor may be used in a circuit that only permits a variation in resistance between 99 and 101 ohms.

The tolerance parameter of a resistor is controlled by several factors, one of which relates to a trimming procedure performed during manufacture of the resistor. The trimming procedure is used to remove excess resistive material from a resistor so as to produce a nominally accurate resistance value. Such a trimming procedure is applicable not only to discrete resistors but also to planar resistors such as those that are employed on a printed circuit board (PCB) or embedded inside integrated circuit (IC) packages. For example, the resistors of a reference voltage node wherein the node is a part of a larger circuit inside an IC, may be trimmed to obtain a desired reference voltage. Such trimming when carried out over a large number of ICs can become an expensive process, potentially resulting in the creation of an undesirable trade-off between circuit performance and cost.

In contrast to a fixed-value reference voltage node, a variable-value reference voltage node can be created by using a variable resistor that is also referred to as a potentiometer. A variable resistor permits a circuit-user the flexibility to vary the value of the variable resistor, thereby allowing programming of a reference voltage value based on specific requirements. Such requirements may be of a variable nature depending upon the needs of a multiplicity of customers or upon the multiplicity of needs of one customer, at any time subsequent to manufacture of the variable resistor. While user-controlled programming of a reference voltage node by the use of a potentiometer, provides an advantage in terms of flexibility-of-use, one shortcoming in doing so, relates to the possibility of accidental misadjustment of the potentiometer thereby leading to potential circuit malfunction.

2

Electronically-controlled potentiometers have been implemented inside ICs to a limited extent. But the use of such electronically-controlled potentiometers in conjunction with additional circuitry inside the same IC is relatively uncommon and may not be typically carried out in a cost-effective manner. For example, it is fairly untypical to provide an electronic potentiometer as a part of a variable-value reference voltage node, such a voltage node being in turn used in conjunction with a comparator circuit inside the same IC. As is known in the art, comparator circuits are used in many applications, including converter circuits such as analog-to-digital converters.

In addition to a reference voltage node, the second class of reference circuit used in various applications such as comparators and converters, is often referred to as a reference current source. A reference current source is typically created from a transistor circuit that incorporates one or more voltages and one or more resistors. The resistor values are selected either by selecting suitable fixed-value discrete resistors or by selecting suitable potentiometers, to generate appropriate currents in the transistor circuit. One example of a circuit used as a reference current source is known in the art as a current mirror circuit. The shortcomings related to resistors, described earlier with reference to voltage sources is also largely applicable to reference current sources.

Applications that use reference voltage nodes and reference current sources will be described in more detail using prior art figures. One such prior art figure, FIG. 1 illustrates an analog-to-digital converter (ADC). While such an ADC can be constructed using discrete devices, such as multiple voltage comparators and resistors that are placed upon a PCB, an ADC is often constructed using devices fabricated upon a substrate inside an IC. The IC packaging provides numerous benefits, yet suffers from the resistor-related handicaps outlined earlier. For example, the accuracy of each of reference voltage values $V_{ref}(n)$ through $V_{ref}(0)$ used in the ADC circuit, is dependent upon the accuracy of each of the resistors, thereby requiring a comparatively expensive trimming process during manufacture. Additionally, once the IC has been manufactured, the reference voltage values cannot be changed because the resistors cannot be readily modified to create other resistance values.

One example of a reason for desiring a change in reference voltage values may arise out of a change in user requirement that necessitates conversion of a linear ADC to a non-linear ADC. In one example of a prior-art linear ADC, each of the resistor values is selected to be identical, thereby creating a multiplicity of reference voltages such that the voltage difference between any one voltage reference node and its neighboring voltage reference node remains identical throughout the resistive divider chain. For example, if the difference between $V_{ref}(n)$ and $V_{ref}(n-1)$ is 0.5V, the difference between $V_{ref}(n-1)$ and $V_{ref}(n-2)$ will also be 0.5V.

On the other hand, in a non-linear ADC, each of the resistor values will be scaled suitably to produce a multiplicity of reference voltages such that the voltage difference between any one voltage reference node and its neighboring voltage reference node is different from a second voltage reference node and its neighboring voltage reference node. For example, if the difference between $V_{ref}(n)$ and $V_{ref}(n-1)$ is 0.5V, the difference between $V_{ref}(n-1)$ and $V_{ref}(n-2)$ may be set at 1.5V—a scaling factor of 3. Such a non-linear ADC will consequently require setting the values of the resistors to non-identical values.

FIG. 2 illustrates one exemplary embodiment of a prior art digital-to-analog converter (DAC) 200, which accepts a multi-bit digital input signal and produces an analog output

voltage that reflects the state of the digital input signal. DAC 200 incorporates n binarily weighted current sources I_O , $I_O/2$, $I_O/2^1$, $I_O/2^2$, \dots , $I_O/2^{n-1}$ that are switched to the output by n current switches located in current switcher 205. The most significant bit (MSB) of the digital input signal determines the state of the switch that switches the I_O current, while the least significant bit (LSB) of the digital input signal determines the state of the switch that switches the $I_O/2^{n-1}$ current. When used as a current-multiplying DAC, it is common for a precision current mirror circuit 215 to generate reference current I_{ref} , which is directly related to the output precision current MI_O . The analog output current MI_O is usually converted into the analog output voltage by an amplifier 220.

Current mirror 215 uses two transistors 216 and 217 that are connected to each other such that current I_{ref} through transistor 216 is "mirrored" by current I_{ref} through transistor 217. While FIG. 2 does not show resistors incorporated into the current mirror circuit 215, most practical applications utilize collector and/or emitter resistors that influence the value of the I_{ref} current. The use of these resistors lead to the limitations described earlier, including limitations such as trimming costs and lack of user-programmability.

FIG. 3 show further details of current switcher 205 and the weighted current generator 210 of FIG. 2. Transistors 312 and 314 constitute one of several differential comparators inside current switcher 205. The LSB of the digital input signal controls the switching of a fractional value of the overall current (MI_O) through transistor 312. The fractional value, which equals $(I_O/2^{n-1})$, is determined by the value of emitter resistor 316 inside the weighted current generator 210.

Transistors 322 and 318 constitute a second one of the several differential comparators inside current switcher 205. The MSB of the digital input signal controls the switching of a fractional value of the overall current (MI_O) through transistor 318. The fractional value, which equals (I_O) , is determined by the value of emitter resistor 324 inside the weighted current generator 210. The sum total of currents that is produced at any instance by the various transistors that have been switched on by the corresponding bits of the digital input signal, constitutes the overall current (MI_O) for any particular digital input signal.

Resistors 316 and 324 are part of a binarily weighted set of resistors, some of which are created by a multiplicity of resistors connected in parallel. The shortcomings of fixed as well as variable resistors that were described earlier, is applicable to this circuit also.

FIG. 4 illustrates a second exemplary embodiment of a prior art digital-to-analog converter (DAC) 400, which accepts a multi-bit digital input signal and produces an analog output voltage that reflects the state of the digital input signal. DAC 400 uses n binarily weighted current sources I_O , $I_O/2$, $I_O/2^1$, $I_O/2^2$, \dots , $I_O/2^{n-1}$ that are output by n transistors 405, 410, \dots , 415. The most significant bit (MSB) of the digital input signal determines the state of transistor 405 that switches the I_O current, while the least significant bit (LSB) of the digital input signal determines the state of transistor 415 that switches the $I_O/2^{n-1}$ current. The analog output current MI_O , which is the sum of the currents through transistors 405, 410, \dots and 415 for any particular digital input signal, is usually converted into the analog output voltage by an amplifier 420. Analog output current MI_O is scaled to be proportional to I_{ref} the reference current that is generated by a current mirror circuit (not shown).

Transistors 405, 410, and 415 constitute three of the n transistors used in DAC 400. These transistors are typically metal oxide semiconductor field-effect transistors (MOSFET). The value of the drain current through any one of these transistors is determined by the applied gate voltage and the source-gate-drain geometry of the device. One of the parameters that determine the relationship between gate voltage and drain current is termed the width/length (W/L) ratio of the channels that define the source, drain, and gate inside the MOSFET. Typically, if a certain drain current is obtained for a particular value of gate voltage, the drain current can be doubled with the gate voltage remaining unchanged, if the (W/L) ratio of the MOSFET is doubled.

As an example, transistor 410 is a MOSFET with a drain current of $(I_O/2)$ for a given gate voltage. The gate voltage in this case will be the digital bit that is one less than the MSB. Transistor 410 is shown in FIG. 4 as having a (W/L) ratio equal to $(2^{n-1} (W/L))$. Transistor 405 has a gate voltage which is identical to the gate voltage applied to transistor 410, because it is equal to a second digital bit (the MSB). Therefore to obtain a drain current in transistor 405 equal to (I_O) , which is double the drain current $(I_O/2)$ through transistor 410, transistor 405 is typically configured to have a (W/L) equal to $(2^n (W/L))$. This (W/L) ratio of transistor 405 is twice the (W/L) ratio of transistor 410.

Such an exponential scaling of transistor sizes to accommodate a range of digital input signal values, is undesirable for several reasons. For example, the component area of the DAC circuit when implemented inside an IC, using a set of identical transistors would be much smaller than the component area when using a set of binarily-sized transistors. Apart from the sub-optimal use of the substrate, the performance of the DAC is also compromised due to several factors. One such factor is increased parasitics, which leads to limitations in sampling speed and bandwidth constraints. A second factor relates to matching the electrical operating characteristics of each transistor to the others in the set of transistors. Typically, the accuracy of a DAC such as DAC 400, will be determined by how well the transistors are matched to one another in providing an accurate binary current-scaling relationship.

Given the shortcomings of the prior art reference voltage nodes and reference current nodes used in various circuits such as analog-to-digital converters and digital-to-analog converters, it is desirable to provide alternative systems and methods that address such shortcomings.

SUMMARY OF THE INVENTION

Embodiments of the present invention provide methods and systems for using a floating-gate MOSFETs as a programmable reference circuit. One example of a programmable reference circuit is a voltage reference source, while a second example of a programmable reference circuit is a reference current source.

Briefly described, in architecture, one embodiment of a system, among others, can be implemented as a floating-gate charge programmer used together with a first floating-gate field effect transistor that is programmable by the floating-gate charge programmer to store a first floating-gate charge and produce at least one of a first reference voltage and a first reference current that is proportional to the first floating-gate charge.

In one embodiment of a method, among others, can be broadly summarized by the following steps: providing a floating-gate field effect transistor; programming a charge into the floating-gate field effect transistor; and thereon

5

using the floating-gate field effect transistor as at least one of a voltage reference and a current reference.

Other systems, methods, features, and advantages of the present invention will be or become apparent to one with skill in the art upon examination of the following drawings and detailed description. It is intended that all such additional systems, methods, features, and advantages be included within this description, be within the scope of the present invention, and be protected by the accompanying claims.

BRIEF DESCRIPTION OF THE DRAWINGS

Many aspects of the invention can be better understood with reference to the following drawings. The components in the drawings are not necessarily to scale, emphasis instead being placed upon clearly illustrating the principles of the present invention. Moreover, in the drawings, like reference numerals designate corresponding parts throughout the several views.

FIG. 1 is a block diagram of one embodiment of a prior-art analog-to-digital converter.

FIG. 2 is a block diagram of one embodiment of a prior-art digital-to-analog converter.

FIG. 3 is a schematic diagram of a current switcher block and a weighted current generator circuit that are used in the prior-art digital-to-analog converter of FIG. 2.

FIG. 4 is a block diagram of a second embodiment of a prior-art digital-to-analog converter.

FIG. 5 is a circuit diagram of a reference circuit incorporating a programmable floating-gate MOSFET that is programmed using an exemplary system operating in a program-mode.

FIG. 6 is a circuit diagram of the reference circuit of FIG. 5 when the exemplary system of FIG. 5 is placed in a run-mode.

FIG. 7 is a block diagram of an exemplary embodiment of a programmable analog-to-digital converter (ADC) incorporating a programmable floating-gate MOSFET, such as the floating-gate MOSFET illustrated in FIGS. 5 and 6.

FIG. 8 is a block diagram of an exemplary embodiment of a programmable digital-to-analog converter (DAC) incorporating a programmable floating-gate MOSFET, such as the floating-gate MOSFET illustrated in FIGS. 5 and 6.

FIG. 9 is a block diagram of an exemplary embodiment of a programmable current-mirror circuit that incorporates a programmable floating-gate MOSFET, such as the floating-gate MOSFET of FIGS. 5 and 6. The current mirror circuit is a part of the digital-to-analog converter of FIG. 8.

FIG. 10 is a block diagram of a second exemplary embodiment of a programmable digital-to-analog converter incorporating a programmable floating-gate MOSFET, such as the floating-gate MOSFET of FIGS. 5 and 6.

FIG. 11 is a block diagram of an exemplary embodiment of a sigma-delta analog-to-digital converter circuit that incorporates a programmable floating-gate MOSFET, such as the floating-gate MOSFET of FIGS. 5 and 6.

DETAILED DESCRIPTION OF THE PREFERRED EMBODIMENT

While the description below refers to certain exemplary embodiments, it is to be understood that the invention is not limited to these particular embodiments. On the contrary, the intent is to cover all alternatives, modifications and equivalents included within the spirit and scope of the invention as defined by the appended claims. Also, the terminology used

6

herein is for the purpose of description and not of limitation. The description draws upon the following documents that are incorporated herein by reference in their entirety:

1) *Investigations using floating-gate circuits for flash ADCs* by Philomena Brady and Paul Hasler

2) *Experimental Investigations of floating-gate circuits for delta-sigma modulators* by Angelo Pereira, Philomena Brady, Abhishek Bandyopadhyay and Paul E. Hasler

3) *Investigating Programmable Floating-Gate Digital-to-Analog Converter as Single Element or Element Arrays* by G. Serrano, Matt Kucic, and Paul Hasler

FIG. 5 is a circuit diagram of a reference circuit 500 incorporating a programmable floating-gate MOSFET 520 that is programmed using an exemplary system 505 operating in a program-mode. The program-mode of operation is implemented to program a charge into the floating-gate of floating-gate MOSFET 520, by using a floating-gate charge programmer 515.

Floating-gate MOSFET 520 contains a floating gate that is typically, but not necessarily, a polysilicon gate surrounded by SiO₂. When an inherent or externally-injected charge is present on the floating-gate, the charge is stored indefinitely because the floating-gate is surrounded by an insulator. The stored charge may be used to control the source-drain current flow in the floating-gate MOSFET 520, because the floating-gate charge behaves as a gate bias voltage.

Consequently, MOSFET 520 may be configured to operate as a reference voltage node and/or as a reference current source, by varying the amount of charge injected into the gate. Varying the amount of charge injected into the gate may be carried out as a one-time operation, as for example during manufacture of an IC that incorporates such a reference voltage source and/or a reference current source. It may also be carried out multiple times, as for example by a user incorporating such a variable reference voltage source and/or a variable reference current source in one or more of his circuit applications.

It will be noted that the term reference current source as used in this disclosure also encompasses applications where the same circuit may be used as a reference current sink. Persons of ordinary skill in the art will recognize that a current-oriented circuit can be operated interchangeably as a source or a sink, depending upon the manner in which such a circuit is connected to another circuit.

Drawing attention to FIG. 5, the source terminal of floating-gate MOSFET 520 is connected to a suitable supply voltage, the gate terminal is connected to an input terminal of voltage buffer 510, and the drain terminal is connected to a switch 525. Switch 525 is operated by floating-gate charge programmer 515 to connect the drain terminal of floating-gate MOSFET 520 to one of two voltages—an injection voltage Vinj that may also be provided by floating-gate charge programmer 515, or a supply voltage that is identical to the source terminal supply voltage. Floating-gate charge programmer 515 also provides a tunneling voltage Vtun into the floating-gate MOSFET 520.

Floating-gate charge programmer 515 comprises for example, voltage sources to provide Vtun and Vinj voltages, control logic to control one or more switches such as switch 525, voltage measurement circuitry to measure the floating-gate charge as well as other voltages, and current measurement circuitry to measure the source-drain current as well as other currents related to one or more MOSFETs such as MOSFET 500.

Capacitor 530 is connected as a negative-feedback capacitor to the voltage buffer 510. An input voltage is provided

into the positive input terminal of voltage buffer **510**. The output voltage V_{out} of voltage buffer **510** may be connected to other circuitry that uses a reference voltage circuit, and is also provided as a measurement voltage to floating-gate charge programmer **515**.

When carrying out program-mode operation, floating-gate charge programmer **515** sets switch **525** to connect V_{inj} into the source terminal of floating-gate MOSFET **500**. When floating-gate MOSFET **500** is a pFET, positive charge in the floating-gate may be increased by using Fowler-Nordheim tunneling to tunnel electrons off the floating-gate thereby increasing hole density. Negative charge in the floating-gate may be increased by using a hot-electron injection process carried out by injecting electrons via V_{inj} . While increasing positive charge at the floating-gate of the pFET causes the source-drain current to decrease, decreasing positive charge at the floating-gate of the pFET causes the source-drain current to increase.

A source-drain current measuring mechanism on the V_{inj} connection may also be used by the floating-gate programmer **515** to determine the appropriate amount of charge to be programmed into the floating-gate to obtain a desired value of source-drain current. This source-drain current is used when floating-gate MOSFET **500** is employed as a reference current source in various applications that will be explained using other figures.

The amplitude of the floating-gate charge is measured via voltage buffer **510**. The voltage buffer **510** allows such a measurement with better accuracy than can be obtained by measuring the voltage directly at the floating-gate. The input voltage provided into the positive terminal of voltage buffer **510** allows the level of the output voltage V_{out} to be set to a value that is suitable for measurement in the floating-gate charge programmer **515**.

It will be understood that several alternative connection schemes may be used to implement the circuit of FIG. 5. For example, switch **525** may be connected to the source terminal of floating-gate MOSFET **520** rather than the drain terminal of floating-gate MOSFET **520**, and/or the gate terminal of floating-gate MOSFET **520** may be connected to the positive rather than the negative input terminal of voltage buffer **505**. The polarity and amplitude of the supply voltages connected to the drain and/or source may also be suitably altered without significantly changing the operating characteristics of floating-gate MOSFET **520**.

FIG. 6 is a circuit diagram of the reference circuit **500** of FIG. 5 when the exemplary system **505** of FIG. 5 is placed in a run-mode. In the run-mode of operation, the terminal of capacitor **530** that was connected to the output of voltage buffer **510** in FIG. 5, is now connected to ground. This connection allows capacitor **530** to operate as an auxiliary storage element connected in parallel to the floating-gate charge inside floating-gate MOSFET **520**.

Floating-gate charge programmer **515** is used to activate switch **525** that consequently connects the drain terminal of floating-gate MOSFET **500** to a supply voltage that is identical to the supply voltage that is connected to the source terminal of floating-gate MOSFET **500**. As a result of this connection, floating-gate MOSFET **500** is placed in a non-conducting state and the floating-gate terminal may now be used as a reference voltage node.

Voltage buffer **510** allows floating-gate MOSFET **500** to be used as a reference voltage node without undue loading of the floating-gate. Such a loading may occur if an external circuit were connected directly to the floating-gate. It will be understood that the use of voltage buffer **510** is optional, and in several applications the floating-gate charge may be used

directly as a reference voltage when floating-gate MOSFET **500** is used as a reference voltage node. The use of floating-gate MOSFET **500** as a voltage reference node and/or a reference current source will be explained further using other figures.

In general, the method for providing a voltage reference node and/or a reference current source may be understood by implementing the following procedure:

A drain terminal (or alternatively, a source terminal) of a floating-gate MOSFET is connected to a supply voltage (V_{dd} when the drain terminal is used; V_{ss} when the source terminal is used). The source terminal (or alternatively the drain terminal) of the MOSFET is connected to an injection voltage source. The charge in the floating-gate is programmed by selectively using a tunneling process and a hot-electron injection process. The output voltage from the voltage buffer is measured to obtain a measurement of the charge. If this output voltage is not appropriate, the tunneling/hot-electron injection process voltage is iteratively continued until the desired level of charge has been programmed.

Once the charge in the gate has been suitably programmed, the source terminal may be disconnected from the injection voltage source and connected to the same supply voltage as the drain terminal. This places the MOSFET in a non-conducting state because both source and drain terminals are at identical voltage potential. The programmed gate terminal of the MOSFET is then used as a reference voltage node. If the MOSFET is to be used as a reference current source, the source terminal can be connected to a supply voltage that biases the source terminal appropriately, and allows the source-drain reference current to flow.

With reference to the method explained above, it will be understood that the drain and source terminals of the MOSFET may be used interchangeably used with appropriate supply voltage biasing and connection of the injection voltage to provide the floating-gate charge at the gate terminal. Also, while a voltage buffer has been used to measure the charge, a current measurement carried out by measuring the source-drain current of the MOSFET may be used as an alternative way to measure the programmed charge.

FIG. 7 is a block diagram of an exemplary embodiment of a programmable analog-to-digital converter (ADC) **700** incorporating one or more floating-gate MOSFETs, such as the floating-gate MOSFET **500** described using FIGS. 5 and 6. The floating-gate MOSFETs, which are programmed using floating-gate charge programmer **745**, are used as reference voltage nodes in this example application. While the exemplary ADC is shown configured as a flash ADC, the use of floating-gate MOSFETs as reference voltage nodes is applicable to a wide variety of ADC systems such as, but not limited to, successive-approximation, dual-slope integration, and staircase ADC systems.

ADC **700** includes n voltage comparators, where n is the number of digital bits that are output by ADC **700**. The value of n defines the resolution that can be provided by ADC **700** to an analog input signal that is connected via line **721** into like-polarity input terminals of the n voltage comparators. In a typical system, the n digital bits are connected into an encoder circuit that produces a unique binary output combination for each of the combinations of the n digital bits.

ADC **700** also includes n floating-gate MOSFETs configured as reference voltage nodes. Each of the n floating-gate MOSFETs is individually connected into like-polarity input terminals of the n voltage comparators. These like-voltage polarity terminals are of opposite polarity to the

like-polarity input terminals into which the analog input signal is connected. For example, floating-gate MOSFET **705** is connected into the negative polarity input terminal of voltage comparator **725**, while the analog input signal is connected into the positive polarity input terminal of voltage comparator **725**. The analog input signal is also connected into the positive polarity input terminals of the other voltage comparators.

While FIG. 7 shows the gate terminal of each MOSFET directly connected to a voltage comparator, it will be understood that a buffer/driver may be optionally used between the gate terminal and the comparator to minimize loading of the charge in the gate terminal by the comparator. Also, for the sake of brevity, the connections between the individual MOSFETs and the floating-gate charge programmer **745** are not shown in FIG. 7. It will be understood that a circuit such as the one described using FIGS. 5 and 6 may be employed to interface the floating-gate charge programmer **745** to the n MOSFETs.

The operation of ADC **700** may be illustrated by using some sample reference voltage values. For example, let it be assumed that floating-gate MOSFET **705** has been programmed to provide a reference voltage of 5.0 V; floating-gate MOSFET **710** has been programmed to provide a reference voltage of 4.0 V; floating-gate MOSFET **715** has been programmed to provide a reference voltage of 3.0 V; and the remaining floating-gate MOSFETs (not shown) have been programmed to provide a difference of 1.0V between adjacent MOSFETs. In this example, if the amplitude of the analog input voltage is 3.5V, voltage comparators **725** and **730** produce zero/low digital output states, because the amplitude of the analog input voltage is lower than the reference voltages fed into the corresponding negative input terminals of these two comparators. All other voltage comparators produce a one/high digital output state, because the amplitude of the analog input voltage is higher than the reference voltages fed into the corresponding negative input terminals of these comparators. The digital output bits (D1 through Dn) are then encoded by the encoder (not shown) to produce a unique binary value corresponding to the 3.5V analog input voltage.

If the analog input voltage is now changed to 4.1 V, only comparator **725** produces a zero/low digital output, while all other comparators, including comparator **730**, produce one/high digital output states. The new set of digital output bits (D1 through Dn) are then encoded by the encoder (not shown) to produce a second unique binary value corresponding to the 4.2V analog input voltage.

In the example illustrated above, the difference in reference voltages provided by adjacent floating-gate MOSFETs was described as a constant 1.0V, thereby causing ADC **700** to respond to varying amplitudes of the input analog voltage in a linear manner. If a non-linear response is desired, the floating-gate MOSFETs may be programmed to provide suitable reference voltages that have non-linear values between adjacent floating-gate MOSFETs. For example, floating-gate MOSFET **705** may be programmed to provide a reference voltage of 5.0 V; floating-gate MOSFET **710** may be programmed to provide a reference voltage of 4.3 V; floating-gate MOSFET **715** may be programmed to provide a reference voltage of 3.1 V; and the remaining floating-gate MOSFETs (not shown) may be programmed with appropriate voltages.

It will be understood that this flexibility in programming, permits ADC **700** to operate in a variety of operating modes that are optionally programmable by an end-user. Such modes of operation encompass ADC responses that are

non-linear, such as but not limited to, exponential, logarithmic, μ -law, and A-law responses. Programming also permits better ADC accuracy, because it permits certain types of device errors to be compensated.

This flexibility in ADC programming is in contrast to ADC devices that are "hardwired" during manufacture to provide one unique mode of operation. Hardwiring refers to the use of components such as resistors in resistive divider chains.

FIG. 8 is a block diagram of an exemplary embodiment of a programmable digital-to-analog converter (DAC) **800** incorporating one or more floating-gate MOSFETs, such as the floating-gate MOSFET illustrated in FIGS. 5 and 6. The floating-gate MOSFETs, which are programmed using floating-gate charge programmer **825**, are used as reference current sources in this example application. While the DAC is shown configured in one exemplary configuration, the use of floating-gate MOSFETs as reference current sources is applicable to a wide variety of DAC systems.

DAC **800** accepts a multi-bit digital input signal and produces an analog output voltage that reflects the state of the digital input signal. DAC **800** uses n binarily weighted current sources $I_o, I_o/2, I_o/2^1, I_o/2^2, \dots, I_o/2^{n-1}$ that are switched floating-gate MOSFETs **805, 810, \dots** and **815**. The MSB of the digital input signal determines the state of floating-gate MOSFET **805** that switches the I_o current, while the LSB of the digital input signal determines the state of floating-gate MOSFET **815** that switches the $I_o/2^{n-1}$ current. The analog output current MI_o , which is the sum of the currents through floating-gate MOSFETs **805, 810, \dots** and **815** for any particular digital input signal, is usually converted into the analog output voltage by an amplifier **820**. Analog output current MI_o is related to I_{ref} the reference current carried on line **823** that is generated by a current mirror circuit (not shown). The current mirror circuit will be explained with reference to another figure.

The n weighted current sources $I_o, I_o/2, I_o/2^1, I_o/2^2, \dots, I_o/2^{n-1}$ can alter have a non-binary relationship. For example, the individual currents can bear an exponential, logarithmic, or a square-law relationship to one another.

The amplitude of the source-drain current through any one of the floating-gate MOSFETs **805, 810, \dots** and **815** is determined by the charge programmed into the floating-gate of the floating-gate MOSFET. The physical characteristics, such as the width-length geometry of each of the floating-gate MOSFETs **805, 810, \dots** **815** is manufactured to be identical to one another, thereby providing several advantages such as producing a good device-to-device match. This matching allows scaling of the binary or non-binary, source-drain currents to be carried out accurately.

It will also be understood, that where such device-to-device matching is less than optimal, the gate charge on the individual MOSFETs may be suitably programmed to offset the mismatch, thereby providing greater accuracy in scaling the multiplicity of source-drain currents using binary as well as non-binary relationships. For example, if MOSFET **805** required a gate voltage of 1V to produce a reference current of 1A, and a gate voltage of 0.5V to produce a reference current of 0.5A, MOSFET **810** that may not be identical to MOSFET **805**, may be provided with a "compensated" gate voltage of 0.6V rather than 0.5V, to produce the desired reference current of 0.5A.

FIG. 9 illustrates an exemplary programmable current-mirror circuit **900** such as the current-mirror circuit used in FIG. 8. Current-mirror circuit **900** includes a pair of floating-gate MOSFETs **910** and **915**. The gate terminal of MOSFET **910** is connected to the gate terminal of MOSFET

915, thereby causing the source-drain current of MOSFET 910 to be “mirrored” by the source-drain current of MOSFET 915. The source-drain current of MOSFET 910 is determined by the charge programmed into the floating-gate of MOSFET 910 by floating-gate charge programmer 925.

Consequently, MOSFET 910 operates as a programmable reference current source that defines the source-drain current of MOSFET 915. While FIG. 9 indicates that the two I_{ref} currents are identical, it will be understood that the two currents may be configured to have other linear as well as non-linear relationships, by suitable addition of resistors in the source-drain path of one or both MOSFETs.

It will also be understood that the MOSFETs can be individually programmed to allow the two MOSFETs to bear a non-linear operational relationship to each other. Additional an input signal, such as a digital signal and/or an analog signal, may also be incorporated into circuit 900, or similar circuits, to permit interaction of the input signal with one or more reference currents through the two MOSFETs.

FIG. 10 is a block diagram of a second exemplary embodiment of a programmable digital-to-analog converter (DAC) 100 incorporating one or more floating-gate MOSFETs, such as the floating-gate MOSFET illustrated in FIGS. 5 and 6. The floating-gate MOSFETs, which are programmed using floating-gate charge programmer 170, are used as reference voltage nodes in this example application. DAC 100 accepts a multi-bit digital input signal and produces an analog output voltage V_{out} that reflects the state of the digital input signal.

DAC 100 uses n capacitors in a capacitor ladder network that is shown in FIG. 10 as having a binary relationship between one another in their capacitance values. Specifically, capacitor 160 is shown as having a capacity C , while capacitor 150 has a capacity of 2^1C , and capacitor 140 has a capacity of 2^nC . Switches 135, 145, and 155 are three of n switches. The individual switch states are determined by the values of the digital inputs. For example, the MSB of the digital input determines the switch state of switch 135, while the LSB of the digital input determines the switch state of switch 155.

The n capacitors are charged by n MOSFETs 105, 110, . . . and 115 depending upon the state of the switch that connects each of the MOSFETs to the corresponding capacitor. The charges contained in one or more of the n capacitors are subsequently summed by amplifier 165. Amplifier 165 provides V_{out} , which is the analog representation of the digital input signal.

MOSFETs 105, 110, and 115 may be programmed to bear a linear and/or a non-linear relationship to one another, thereby causing DAC 100 to output an analog signal that bears a linear or a non-linear relationship to the digital input.

FIG. 11 is a block diagram of an exemplary embodiment of a sigma-delta analog-to-digital converter circuit that incorporates the programmable floating-gate reference circuit of FIGS. 5 and 6. While FIG. 11 illustrates an n^{th} -order, 1-bit sigma-delta converter circuit that is also referred to as a sigma-delta converter circuit, the following description is also applicable to several other converter circuits, including n -bit converters that utilize a voltage reference node or a reference current source. Also, while FIG. 11 illustrates a 1-bit over-sampling converter circuit, the example provided in this description may be extended to multi-bit implementations as well.

Converter 175 accepts an analog input voltage through line 196 and outputs a 1-bit digital output on line 197. This 1-bit digital output is compared with the input voltage by using a feedback loop comprised of several multiplexers,

combiners, and signal transform blocks. When the signal transform block is an integrator circuit, the integrated result of the comparison is used to generate a subsequent 1-bit digital output on line 197. The digital output on line 197 consequently comprises a stream of “ones” and “zeros” that represent the analog input voltage as a ratio of “ones” and “zeros.”

Converter 175 comprises $2n$ floating-gate MOSFETs that are individually programmable using floating-gate charge programmer 180. The MOSFETs are used as reference voltage nodes in this example application. Line 197 is connected to n 2-input multiplexers 183, 194, . . . and 177 that are connected to n combiners 184, 189, . . . and 176. The output of each combiner is connected to a signal transform block. Transform block 198 connects into an output comparator 192 that in turn connects into an optional latch 193 that drives line 197. Other than transform block 198, the outputs of each of the other remaining transform blocks 191 . . . 187, are individually connected into a first input of $(n-1)$ 2-input multiplexers 186 . . . 188. The analog input signal on line 196 is provided into the second input of each of the $(n-1)$ 2-input multiplexers 186 . . . 188.

The value of n , which determines the n^{th} -order of operation of the n^{th} -order, 1-bit sigma-delta modulator circuit, is determined by the logic (logic controller not shown) present on the control lines 156 and 157 (other lines not shown) of the $(n-1)$ 2-input multiplexers 186 . . . 188. For example, to configure the n^{th} -order, 1-bit sigma-delta modulator circuit as a first-order 1-bit converter, the logic present on control line 156 of multiplexer 186 is set to route the analog input signal on line 196 into the combiner 184. Such a configuration effectively prevents the 2^{nd} -order input from transform block 191, as well as the higher-order inputs from other transform blocks, from appearing at combiner 184.

To increase the order of operation to 2, the logic present on control line 156 of multiplexer 186 is suitably selected to route the signal from transform block 191 into the combiner 184, while the logic present on control line 157 of multiplexer 188 is suitably selected to route the analog input signal on line 196 into the combiner 189.

The logic state of the 1-bit digital output on line 197 that is connected to the n 2-input multiplexers 183, 194, . . . and 177, determines which of the two MOSFETs connected to the multiplexers are routed to each of the respective combiners. For example, if the logic state is one/high, MOSFETs 182, 172, . . . and 179, may be routed through multiplexers 183, 194, . . . and 177; and if the logic state is zero/low, MOSFETs 181, 171, . . . and 178, may be routed through multiplexers 183, 194, . . . and 177.

The reference voltage values provided by the $2n$ MOSFETs are programmed using the floating-gate charge programmer 180. Programming may be carried out to individually or collectively program the floating-gate charge inside each of the $2n$ MOSFETs. These reference voltage values determine the coefficients of the feedback loop of the converter 175. These coefficients are used for signal transformation such as integration and/or filtering, in the transform blocks 191 . . . and 187.

It will be understood that the floating gate charges may be modified in a one-time manner, repetitively, randomly, recursively, or in other dynamic sequences, thereby allowing the operating characteristics of the converter 175 to be alterable statically or dynamically. This flexibility in changing operating characteristics of the converter 175 provides several advantages. For example, it allows the loop gain to be optimized while ensuring accuracy and stability of operation for a given range of analog input signal amplitudes.

13

It should be emphasized that the above-described embodiments of the present invention, particularly, any “preferred” embodiments, are merely possible examples of implementations, merely set forth for a clear understanding of the principles of the invention. Many variations and modifications may be made to the above-described embodiment(s) of the invention without departing substantially from the spirit and principles of the invention. All such modifications and variations are intended to be included herein within the scope of this disclosure and the present invention and protected by the following claims.

What is claimed is:

1. A system comprising:

a floating-gate charge programmer;

a switch operative to provide a program-mode of operation and a run-mode of operation; and

a first floating-gate field effect transistor that is programmable by the floating-gate charge programmer to store a first floating-gate charge when the switch is operative in the program-mode of operation, and to produce, when the switch is operative in the run-mode of operation, at least one of a first reference voltage or a first reference current proportional to the first floating-gate charge;

wherein the floating-gate charge programmer is operative to generate a switch control signal to control operation of the switch.

2. The system of claim 1, wherein the first floating-gate field effect transistor is a part of a voltage comparator circuit.

3. The system of claim 1, further comprising a voltage comparator, wherein the first reference voltage is provided to a first input of the voltage comparator, an analog input signal is provided to a second input of the voltage comparator, and wherein the voltage comparator produces an output signal that is a digital representation of the difference in amplitudes between the first reference voltage and the analog input signal.

4. The system of claim 3, further comprising an analog-to-digital converter, wherein the voltage comparator is one of a plurality of voltage comparators, and the first floating-gate field effect transistor is one of a plurality of floating-gate field effect transistors that are used to produce a plurality of reference voltages.

5. The system of claim 1, further comprising a digital-to-analog converter containing a second floating-gate field effect transistor that is programmable by the floating-gate charge programmer to store a second floating-gate charge when the switch is operative in the program-mode of operation, and to produce, when the switch is operative in the run-mode of operation, at least one of a second reference voltage or a second reference current proportional to the second floating-gate charge.

6. The system of claim 5, wherein the digital-to-analog converter comprises a summing amplifier that combines at least one of the first reference voltage or the first reference current when enabled by a first digital logic, with at least one of the second reference voltage or the second reference current when enabled by a second digital logic, to produce an analog signal that is representative of the digital logic combination of the first and second digital logic.

7. The system of claim 6, wherein the amplitude of the first reference voltage has a binary relationship to the amplitude of the second reference voltage.

8. The system of claim 6, wherein the amplitude of the first reference current has a binary relationship to the amplitude of the second reference current.

14

9. The system of claim 1, further comprising a second floating-gate field effect transistor that is connected to the first floating-gate field effect transistor to form a current-mirror circuit wherein the source-drain current of the second floating-gate field effect transistor is proportional to the source-drain current of the first floating-gate field effect transistor.

10. The system of claim 1, further comprising a second floating-gate field effect transistor that is connected to the first floating-gate field effect transistor to form a current-summing circuit wherein the output current of the current-summing circuit is proportional to the sum of the source-drain currents of the first and the second floating-gate field effect transistors.

11. The system of claim 1, wherein the floating-gate charge programmer further comprises at least one of a voltage measurement circuit to measure the first floating-gate charge or a current measurement circuit to measure a source-drain current of the first floating-gate field effect transistor.

12. A system comprising:

a flash analog-to-digital converter containing a plurality of voltage comparators;

a switch operative to provide a program-mode of operation and a run-mode of operation;

a first floating-gate field effect transistor connected to a first voltage comparator in the plurality of voltage comparators, the first floating-gate field effect transistor being programmable to store a first floating-gate charge when the switch is operative in the program-mode of operation, and to produce, when the switch is operative in the run-mode of operation, a first reference voltage output that is proportional to the first floating-gate charge;

a second floating-gate field effect transistor connected to a second voltage comparator in the plurality of voltage comparators, the second floating-gate field effect transistor being programmable to store a second floating-gate charge and produce a second reference voltage that is proportional to the second floating-gate charge; and

a third floating-gate field effect transistor connected to a third voltage comparator in the plurality of voltage comparators, the third floating-gate field effect transistor being programmable to store a third floating-gate charge and produce a third reference voltage output that is proportional to the third floating-gate charge,

wherein the first voltage reference output, the second voltage reference output, and the third voltage reference output provide a logarithmic change in voltage reference amplitudes for a flash analog-to-digital conversion in the flash analog-to-digital converter.

13. A method of providing a reference, the method comprising:

providing a floating-gate field effect transistor;

providing a switch;

setting the switch in a first position to program a charge into the floating-gate field effect transistor, wherein programming the charge into the floating-gate field effect transistor includes:

connecting a gate terminal of the floating-gate field effect transistor to a first input terminal of a voltage buffer;

connecting an input voltage signal to a second input terminal of the voltage buffer;

15

providing a feedback capacitor that capacitively couples an output voltage of the voltage buffer to the gate terminal of the floating-gate field effect transistor;

selectively providing one of a hot-electron charge injection process and a tunneling process to the floating-gate field effect transistor to adjust the amplitude of charge stored in the floating-gate field effect transistor to a desired amplitude; and

measuring the output voltage of the voltage buffer to determine the amplitude of charge stored in the floating-gate field effect transistor; and

setting the switch in a second position to use the floating-gate field effect transistor as at least one of a voltage reference or a current reference.

14. The method of claim 13, wherein upon programming the charge into the floating-gate field effect transistor, further configuring the floating-gate field effect transistor as a voltage reference by:

disconnecting a lead of the feedback capacitor that is connected to the output terminal of a voltage comparator; and

connecting the lead of the feedback capacitor to a ground potential.

15. A method of providing a reference, the method comprising:

providing a floating-gate field effect transistor; connecting a drain terminal of the floating-gate field effect transistor to a first supply voltage;

connecting a source terminal of the floating-gate field effect transistor to an injection voltage source;

selectively providing one of a hot-electron charge injection process and a tunneling process to the floating-gate field effect transistor to adjust the amplitude of charge stored in the floating-gate field effect transistor to a desired amplitude;

disconnecting the source terminal of the floating-gate field effect transistor from the injection voltage source;

connecting the source terminal of the floating-gate field effect transistor to the first supply voltage; and using the floating-gate field effect transistor as a reference voltage node.

16. A method of providing a reference, the method comprising:

providing a floating-gate field effect transistor; connecting a drain terminal of the floating-gate field effect transistor to a first supply voltage;

connecting a source terminal of the floating-gate field effect transistor to an injection voltage source;

selectively providing one of a hot-electron charge injection process and a tunneling process to the floating-gate field effect transistor to adjust the amplitude of charge stored in the floating-gate field effect transistor to a desired amplitude;

disconnecting the source terminal of the floating-gate field effect transistor from the injection voltage source;

connecting the source terminal of the floating-gate field effect transistor to a second supply voltage; and using the floating-gate field effect transistor as a reference current source.

17. A method of providing a reference, the method comprising:

providing a floating-gate field effect transistor; connecting a source terminal of the floating-gate field effect transistor to a first supply voltage;

connecting a drain terminal of the floating-gate field effect transistor to an injection voltage source;

16

selectively providing one of a hot-electron charge injection process and a tunneling process to the floating-gate field effect transistor to adjust the amplitude of charge stored in the floating-gate field effect transistor to a desired amplitude;

disconnecting the drain terminal of the floating-gate field effect transistor from the injection voltage source;

connecting the drain terminal of the floating-gate field effect transistor to the first supply voltage; and

using the floating-gate field effect transistor as a reference voltage node.

18. A method of providing a reference, the method comprising:

providing a floating-gate field effect transistor;

connecting a source terminal of the floating-gate field effect transistor to a first supply voltage;

connecting a drain terminal of the floating-gate field effect transistor to an injection voltage source;

selectively providing one of a hot-electron charge injection process and a tunneling process to the floating-gate field effect transistor to adjust the amplitude of charge stored in the floating-gate field effect transistor to a desired amplitude;

disconnecting the drain terminal of the floating-gate field effect transistor from the injection voltage source;

connecting the drain terminal of the floating-gate field effect transistor to a second supply voltage; and

using the floating-gate field effect transistor as a reference current source.

19. A method of providing a reference, the method comprising:

setting a switch in a first position to program a charge into a floating-gate field effect transistor;

connecting a gate terminal of the floating-gate field effect transistor to a first input terminal of a voltage buffer;

connecting an input voltage signal to a second input terminal of the voltage buffer; and

providing a feedback capacitor that capacitively couples an output voltage of the voltage buffer to the gate terminal of the floating-gate field effect transistor.

20. The method of claim 19, further comprising:

selectively providing one of a hot-electron charge injection process and a tunneling process to the floating-gate field effect transistor to adjust the amplitude of charge stored in the floating-gate field effect transistor to a desired amplitude; and

measuring the output voltage of the voltage buffer to determine the amplitude of charge stored in the floating-gate field effect transistor.

21. The method of claim 20, further comprising:

setting the switch in a second position to use the floating-gate field effect transistor as at least one of a voltage reference or a current reference.

22. A system comprising:

a floating-gate charge programmer;

a switch operative to provide a program-mode of operation and a run-mode of operation;

a digital-to-analog converter including:

a first floating-gate field effect transistor that is programmable by the floating-gate charge programmer to store a first floating-gate charge when the switch is operative in the program-mode of operation, and to produce, when the switch is operative in the run-mode of operation, at least one of a first reference voltage or a first reference current proportional to the first floating-gate charge; and

17

a second floating-gate field effect transistor that is programmable by the floating-gate charge programmer to store a second floating-gate charge when the switch is operative in the program-mode of operation, and to produce, when the switch is operative in the run-mode of operation, at least one of a second reference voltage or a second reference current proportional to the second floating-gate charge.

23. The system of claim **22**, wherein the digital-to-analog converter comprises a summing amplifier that combines at least one of the first reference voltage or the first reference current when enabled by a first digital logic, with at least one of the second reference voltage or the second reference current when enabled by a second digital logic, to produce an analog signal that is representative of the digital logic combination of the first and second digital logic.

24. The system of claim **23**, wherein the amplitude of the first reference voltage has a binary relationship to the amplitude of the second reference voltage.

25. The system of claim **23**, wherein the amplitude of the first reference current has a binary relationship to the amplitude of the second reference current.

26. A system comprising:

a floating-gate charge programmer;

a switch operative to provide a program-mode of operation and a run-mode of operation; and

a first floating-gate field effect transistor that is programmable by the floating-gate charge programmer to store a first floating-gate charge when the switch is operative in the program-mode of operation, and to produce,

18

when the switch is operative in the run-mode of operation, at least one of a first reference voltage or a first reference current proportional to the first floating-gate charge; and

a second floating-gate field effect transistor that is connected to the first floating-gate field effect transistor to form a current-mirror circuit wherein the source-drain current of the second floating-gate field effect transistor is proportional to the source-drain current of the first floating-gate field effect transistor.

27. A system comprising:

a floating-gate charge programmer;

a switch operative to provide a program-mode of operation and a run-mode of operation;

a first floating-gate field effect transistor that is programmable by the floating-gate charge programmer to store a first floating-gate charge when the switch is operative in the program-mode of operation, and to produce, when the switch is operative in the run-mode of operation, at least one of a first reference voltage and a first reference current proportional to the first floating-gate charge; and

a second floating-gate field effect transistor that is connected to the first floating-gate field effect transistor to form a current-summing circuit wherein the output current of the current-summing circuit is proportional to the sum of the source-drain currents of the first and the second floating-gate field effect transistors.

* * * * *

UNITED STATES PATENT AND TRADEMARK OFFICE
CERTIFICATE OF CORRECTION

PATENT NO. : 7,034,603 B2
APPLICATION NO. : 10/446087
DATED : April 25, 2006
INVENTOR(S) : Brady et al.

Page 1 of 1

It is certified that error appears in the above-identified patent and that said Letters Patent is hereby corrected as shown below:

Title page, Item (75) Inventors:
Should read:

-- Philomena Cleopha Brady, Garland, TX (US): Guillermo Jose Serrano, Atlanta, GA (US): Farhan Adil, Silver Springs, MD (US): Matthew Raymond Kucic, Austell, GA (US): Paul Edward Hasler, Atlanta, GA (US): Angelo W. Pereira, Atlanta, GA (US) --.

Signed and Sealed this

Eighteenth Day of July, 2006

A handwritten signature in black ink on a light gray dotted background. The signature reads "Jon W. Dudas" in a cursive style.

JON W. DUDAS

Director of the United States Patent and Trademark Office