

A NOVEL APPROACH TO FABRIC CONTROL FOR AUTOMATED SEWING

Ryder C. Winck

Woodruff School of Mechanical Engineering
Georgia Institute of Technology
Atlanta, GA 30318
ryder@gatech.edu

Wayne J. Book

Woodruff School of Mechanical Engineering
Georgia Institute of Technology
Atlanta, GA 30318
wayne.book@me.gatech.edu

Steve Dickerson

Woodruff School of Mechanical Engineering
Georgia Institute of Technology
Atlanta, GA 30318
steve.dickerson@camotion.com

James D. Huggins

Woodruff School of Mechanical Engineering
Georgia Institute of Technology
Atlanta, GA 30318
james.huggins@me.gatech.edu

ABSTRACT

This paper describes a novel fabric manipulation method for fabric control during the sewing process. It addresses issues with past attempts concerning fabric position and tension control. The method described involves replacing the current sewing feed mechanism with a servo controlled manipulator to both feed and control the fabric. The manipulator is coupled with a machine vision system that tracks the threads of the fabric to provide real-time position control that is robust with respect to fabric deformations. A prototype of the manipulator is used to demonstrate the feasibility of the concept, reaching accelerations up to 27 g's and following a closed loop trajectory with open loop control while operating in coordination with an industrial sewing machine. The system described also offers a general solution to high accuracy and high acceleration position control systems.

INTRODUCTION

Nearly every phase of garment manufacturing involves skilled labor, and the procedures for production and quality control are largely based on a nonnumeric description of quality and an understanding of the materials [1]. The evidence of the lack of automation in the apparel industry is demonstrated by its growth in developing countries with a low cost labor force and its decline in industrialized nations where labor is more expensive.

During the 1980s, millions of dollars were spent towards automating the garment manufacturing process in the

United States, Japan and industrialized Europe [2]. Those efforts were unable to successfully automate the entire garment manufacturing process, although some technological breakthroughs were integrated into current manufacturing techniques. Outside of research by a handful of university faculty, little has been done in the way of automatic garment manufacturing since the 1980s. Most research attempts have centered on fitting an industrial style robot arm, such as a Puma robot, with a custom end effector to hold the fabric to a surface and change the angle of the fabric while the sewing machine feeds the fabric using its typical sewing dog system. One of the earliest attempts was by Frank Paul at Clemson University [3]. His system used machine vision to detect the edge of a piece of fabric, plan a seam path at an offset to that edge and determine the placement of the end effector on the fabric. However, the vision system was not used for real-time feedback. Although the system was relatively successful, the use of vision to detect fabric edges has been identified as lacking robustness due to outgoing filaments, inhomogeneous cuts, and wrinkles in the fabric and thus insufficient for automated sewing [4]. In addition, the project dealt only with manipulating a single piece of fabric and ignored the joining of multiple fabrics. Finally, the results showed the need for real-time feedback during the sewing process.

David Gershon, at the Weizmann Institute of Science in Israel, extended Paul's work by using a similar setup with a traditional industrial sewing machine and industrial robotic manipulator but adding real-time feedback and closed-loop

control [5]. He divided the sewing process into four tasks: contour tracking, tension control, robot feed control and sewing. A standard sewing dog was used to feed the fabric, but the feed rate was computer controlled. The manipulator was given the task of matching the feed rate. A separate control loop was used to maintain proper tension in the fabric based on a force sensor in the end effector. The robot also changed the orientation of the fabric to follow a contour edge using machine vision to detect the edge. The vision system provided real-time feedback to determine the robot trajectory. Although the results were still not very robust with respect to fabric type and sewing speed, the work did outline a set of six performance criteria for automated sewing: (1) hold constant seam width (2) maintain proper fabric tension (3) prevent fabric buckling (4) operate and control sewing machine (5) avoid obstacles and singularities and (6) avoid torque limits. The robustness deficiency centered on the first three objectives, which are associated with sewing quality.

To reduce the error in tension control, fuzzy logic and neuro-controllers were applied to a similar system by Panagiotis Koustoumpardis and Nikos Aspragathos [1]. The objective was to meet the criteria set forth by Gershon with greater robustness and without quantitative understanding of fabric properties by using qualitative knowledge of fabric properties such as extensibility and flexibility to provide inputs to a neuro-controller. While the results showed improved robustness, the system involved a single piece of fabric and did not address the issue of attaching two pieces of fabric together.

In 2008, Honghai Liu at the University of Portsmouth identified five areas of current research in the area of automated fabric handling: sensing, handling, material properties, modeling and prediction, and intelligent planning [6]. This paper focuses on sensing and handling as they pertain to the sewing task specifically and automated fabric handling in general.

No fabric control strategy to date has made a successful jump from prototype to a useful real-world method. Obstacles include the lack of an accurate and robust position control method, the difficulties arising from using a continuous robotic manipulator to maintain proper tension in the fabric as it is being fed by an incrementally applied actuator, and the focus of research on controlling a single sheet of fabric despite the necessity of controlling two sheets of fabric during the sewing process. In maintaining proper fabric tension, tension measurement is used to detect error in the feed rate of the robot relative to the dogs. The objective of the controller is to prevent the fabric from buckling due to compression or tension, which results in a poor quality seam. Tension measurement has not proven a method that is robust enough given the wide range of fabric properties.

The use of an overhead vision system and industrial manipulator, coupled with a standard sewing machine has not shown the ability to perform adequately regardless of the control strategy or trajectory generation used. The primary problem is a lack of robustness in the design based on deficiencies in the sensing methods and inaccuracy in the manipulators. In addition, no previous methods were developed to sew multiple sheets of fabric. The use of more precise sensors and actuators and more advanced control methods has been shown to increase the robustness but has not been entirely successful. New strategies are needed to meet the challenges of incorporating automation into garment manufacturing. This paper lays out a new methodology by which automated sewing may be realized. It focuses on a subset of automated sewing, namely the precise actuation and sensing of fabric near the sewing head.

A method of fabric actuation at the sewing head will be described as well as a prototype demonstrating the concept's feasibility. Unlike previous research, the feed mechanism of the sewing machine is redesigned to control both the feeding of the fabric as well as the orientation of the fabric using an incremental actuation method. This method can be adapted to any high-speed, high-accuracy application. In order to provide position feedback of the fabric for closed-loop control, a new machine vision approach also is suggested. Finally, the method is extended to multiple fabric sheets in order that they may be sewn together.

CONCEPTUAL DESIGN

Precise fabric handling is needed at the sewing head. Stitch lengths generally are 0.5-4 mm in length but can be longer for heavy weighted fabrics. Stitch accuracy must therefore be within fractions of a millimeter in order to be acceptable. Instead of using a robotic arm in addition to the sewing machine, actuation will be performed by an adaptation of the existing sewing machine feed dog. Currently a sewing machine uses a sewing dog to move the fabric through the sewing head. The motion of the dog is incremental and follows the pattern described below in Figure 1. On a standard sewing machine, the dog moves at a relatively fixed speed that is directly related to the sewing speed and to the stitch length. Longer stitches and faster sewing speeds result in faster dog movement. While the sewing dog feeds the fabric through the machine, the operator must maintain the fabric orientation and keep up with the feed rate. Previous attempts at automated sewing used the sewing dogs on a standard sewing machine and had a robot perform exactly the operations a human user would perform. Maintaining proper tension in the fabric was noted to be a major hurdle to this method in addition to a lack of robust control of fabric position due to fabric's complex and highly variable properties.

This project endeavors to replace the standard sewing dog and user with servo controlled dogs. Therefore, the actuators need to be able to feed the fabric through the

sewing head in much the same way that the current sewing dog does. They must also be able to change the orientation of the fabric as the human currently does. By using the feed dog mechanism as the method by which to control the fabric, the difficulties of fabric feed rate, tension control, and fabric position control can all be more adequately addressed. In order to be able to function in the sewing process, the actuators must also work in conjunction with the sewing needle just as does a standard sewing dog. Thus, the fabric control method is not continuous, but incremental, which will more easily coordinate with a sewing machine that currently works with an incremental feed system. Using an actuator that mimics the current method of the sewing dog but adds control provides a promising solution to an as-yet unsolved problem, and in doing so, suggests a solution to any system that requires high-speed and high-accuracy control.

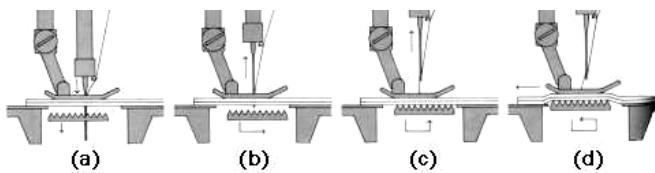

FIGURE 1 THE SEWING NEEDLE PENETRATES THE FABRIC WHILE THE PRESSER FOOT HOLDS THE FABRIC IN PLACE (A). THE NEEDLE MOVES UP THROUGH THE FABRIC, MAKING THE STITCH WHILE THE DOG MOVES FORWARD AND UP (B). THE NEEDLE EXITS THE FABRIC AND THE DOG CONTACTS THE FABRIC (C). THE DOG ADVANCES THE FABRIC FOR THE NEXT STITCH WHILE THE NEEDLE IS BROUGHT BACK DOWN (D)

The actuators must meet a number of performance criteria in order to be sufficient to perform the task of fabric control for automated sewing, including the ability to operate at high speeds and in time with the sewing needle. Therefore, the individual motions of the actuators are short in duration. The maximum travel needs only to be the distance of the longest stitch length anticipated for the application. Typical sewing speeds for non-autonomous sewing are around 5,000 stitches per minute, which is about 80 Hz. Assuming an average stitch length of 2 millimeters, the servo actuators must be able to accelerate up to about 20 g's or 196 m/s² in order to compete with the speed of the current manual sewing process. The accuracy of the dog's motion must be proportional to the length of travel because large variations in stitch length and stitch position cause unacceptably poor seam quality. In other words, the position accuracy should be on the order of fractions of a millimeter. Fabric position feedback is necessary and must be accurate enough to sense changes in position on the order of fractions of a millimeter to correct for errors that will arise due to factors such as slip between the actuator and the fabric.

In addition to the above performance requirements, the actuators must be able to control the fabric in multiple degrees of freedom. The actuators must move the fabric

forward and back to advance the fabric through the sewing head in a manner similar to the current feed dog. However, to replace the human, the actuators must also be able to rotate the fabric. If one considers the fabric as a rigid body, then these two degrees of freedom would be sufficient for controlling the fabric on a flat surface. However, due to fabric's high extensibility, three additional degrees of freedom must be controlled. Finally, to avoid the challenge of rotating the fabric through large angles, which would result in large translations of the fabric far from the point of rotation, the ability to move the fabric left and right would be useful to sew acute angles. These six degrees of freedom are depicted in Figure 2.

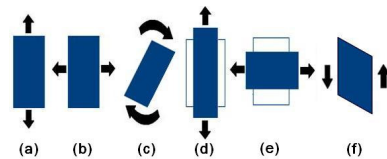

FIGURE 2 FABRIC ON A SURFACE HAS SIX DEGREES OF FREEDOM: TWO DIRECTIONS OF TRANSLATION (A) (B), ONE DIRECTION OF ROTATION (C), TWO DIRECTIONS OF STRETCH (D) (E) AND ONE DIRECTION OF SHEAR (F)

Therefore, all six degrees of freedom could be necessary on a commercial system, but only two degrees of freedom are truly essential if fabric deformation can be minimized. To meet these requirements, the actuators must be small, light and fast. In addition, they must have multiple degrees of freedom that can be accurately position controlled, and they must be computer controlled to interface with the sewing machine, vision system and other stages in the larger garment manufacturing system.

To understand how these actuators can move the fabric, it is helpful to think of the actuators as simple blocks that can move forward, back, side-to-side and rotate. To obtain all six degrees of freedom, two actuators are needed. Figure 3 demonstrates how five of the degrees of freedom can be controlled using two actuators.

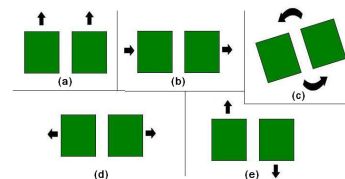

FIGURE 3 THE BLOCKS REPRESENT THE SERVO CONTROLLED DOGS AND THE ARROWS SHOW HOW FIVE DEGREES OF FREEDOM CAN BE CONTROLLED: TRANSLATION UP/BACK (A), TRANSLATION LEFT/RIGHT (B), ROTATION (C), STRETCH IN ONE DIRECTION (D), AND SHEAR (E)

The sixth degree of freedom, fabric tension in the direction parallel to the sewing line, must be maintained using coordinated control between the actuators and a potential fabric conveyor system. In this configuration, each actuator would need three degrees of freedom of actuation – two for translation and one for rotation. This is omitting the out-of-plane actuation to provide incremental contact with the fabric as with current sewing dogs. The out-of-plane motion does not need to be position controlled, but does need to move up and down 180° out of phase with the sewing needle.

In addition to multiple degrees of freedom, the actuators must be able to control two sheets of fabric, which overcomes a significant deficiency in previous attempts at automated sewing. The simplest solution would appear to be to position the two plies perfectly aligned, one on top of the other, using a single actuator to control both plies simultaneously and relying on friction between the two plies to move the bottom ply. However, slip between the two plies would result in position errors for the lower sheet of fabric. Even if it were possible to control the two sheets with a single actuator, the process of stacking the two sheets of fabric on top of one another would be very difficult at best. A better solution is to separate the two sheets with a surface between them, such as a thin plate, as shown in Figure 4 and have actuators above and below the plate for each ply. This allows both sheets to be independently controlled and properly aligned, although it doubles the number of sensors, cameras, and actuators. In addition, the thin plate acts as a surface for the actuators to push against, which on a standard sewing machine is done by pushing up against the presser foot.

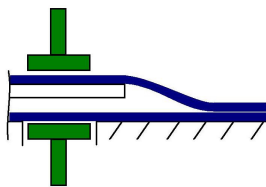

FIGURE 4 A THIN PLATE SEPARATES TWO SHEETS OF FABRIC. EACH SHEET IS INDIVIDUALLY CONTROLLED BY TWO MANIPULATORS ALTHOUGH ONLY ONE CAN BE SEEN IN THIS SIDE VIEW

Thus, for five degrees of freedom of control for two sheets of fabric, four manipulators would be needed, two for the top fabric and two for the bottom fabric. Each manipulator would use two motors. For fabric position feedback, each set of two manipulators would have a thread-level vision system. One set would be above the fabric, controlling the top sheet, and the other set would be below the fabric to control the bottom sheet. This would allow for translation in multiple directions, rotation, horizontal stretch and shear.

For the actuators at the sewing head to achieve high position accuracy, fabric position sensing must be precise

because it determines the stitch position and stitch length. Attempts at automated sewing using pre-planned paths have noted the need for real-time position sensing. A major hurdle in using machine vision to provide position feedback has been the errors introduced by variability of the edges of fabric due to outgoing filaments and deformation of the cloth off of the table surface [4]. To alleviate these issues, a new vision technique is proposed and has been demonstrated as a prototype to provide fabric position information by tracking individual threads in the fabric. This method will provide information to the actuators to allow them to control the fabric through a closed trajectory. Therefore, the position of the fabric is measured in threads rather than millimeters or inches. Using previous methods, fabric position is based on the shape of the fabric relative to a global coordinate system. So any fabric deformation results in position error. Using the fabric's threads for position detection avoids errors due to deformation. It also avoids problems of noise in the fabric edge.

A complete fabric control system will thus be comprised of a thin plate just above the table surface in front of the sewing head, one or two servo controlled “dogs” above and below the thin plate with two to three degrees of freedom each, and two vision systems to provide position feedback based on fabric threads. Figure 5 shows a visual representation of the system. In addition to these new components, some of the existing components of the sewing machine must be removed or modified. The current sewing dogs are removed and replaced by the servo controlled dogs. The presser foot will need to move up and down in time with the needle to hold the fabric during stitching, but release the fabric to allow the servo controlled dogs to push the fabric through the sewing head.

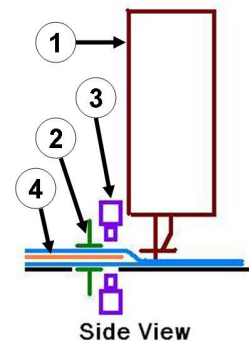

FIGURE 5 COMPLETE AUTOMATED SYSTEM WITH COMPONENTS: SEWING MACHINE (1), MANIPULATORS (2), CAMERAS (3), THIN PLATE (ORANGE) AND FABRIC (4).

For a complete garment manufacturing system, other components would be necessary. There must be a method by which to transport fabric to the sewing table, place it on the table, and then convey it towards the sewing head. Overhead grippers for fabric transport have been dealt with previously

[7-11]. A fabric conveyor system is currently being developed at Georgia Institute of Technology to work in conjunction with the servo controlled dog system.

PROTOTYPE

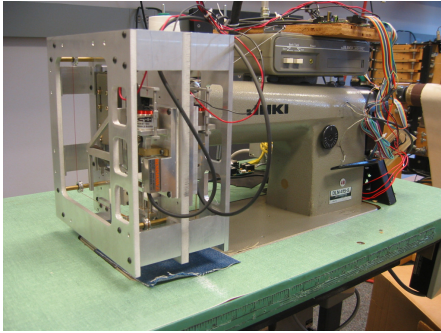

FIGURE 6 PROTOTYPE SERVO CONTROL MANIPULATOR MOUNTED ON A SEWING MACHINE

A prototype of the proposed actuator, shown in Figure 6, has been developed to demonstrate the feasibility of servo control at the high speeds, accuracy and precision required. The design uses highly responsive voice coil motors with a peak force of 10 N. The system uses optical encoders for position control of the voice coil motors, but the position control of the fabric itself is currently open loop control using a pre-defined path. The voice coil motors are mounted separately from the dog itself.

A cable drive system is used to transfer motion from the voice coil motors to the dog. Each cable system uses one flexible cable, which can be thought of as a spring, and one stiff cable. This allows the two voice coil motors to actuate the dog in multiple degrees of freedom without having to move any of the motors or lose position accuracy. The total equivalent mass of the system, including inertial components is, 31.6 grams, which permits theoretical accelerations up to 32 g's using the voice coil motors.

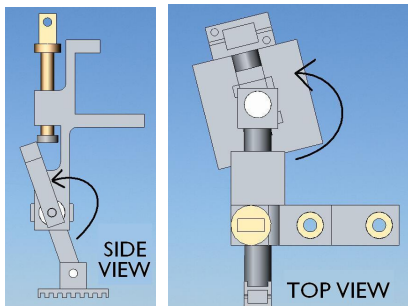

FIGURE 7 TRANSLATION MOTION OF THE DOG MADE BY ROTATING LONGER ARM AS SHOWN ON LEFT. ROTATION MOTION OF THE DOG MADE BY ROTATING SHORTER ARM AS SHOWN ON RIGHT. THE TWO MOTIONS ARE DECOUPLED, MEANING THAT THE ROTATION IS UNAFFECTED BY THE TRANSLATION

A single dog is used to achieve both forward and reverse motion and rotation, or two degrees of freedom, as shown in Figure 7. This is sufficient for obtaining in-plane motion but cannot stretch or shear the fabric. The entire device is mounted on an industrial sewing machine that has been slightly modified to allow for the servo dog. For out-of-plane motion, the dog is mechanically attached to the sewing needle to guarantee proper timing. Therefore, as the sewing machine motor drives the needle up and down, the dog moves up and down 180° out of phase with the needle. The cable drive system allows the dog to move vertically without affecting the position control. An IR reflective optical sensor is used to indicate whether the needle is out of the fabric or in the fabric.

A block diagram of the entire system as it would be integrated into a complete garment manufacturing system is shown in Figure 8. It is controlled by a C program running on a Windows PC. The PC communicates with the motors, encoders and sensor using two motor controllers that interface serially with the PC. The thread-level vision system is not incorporated with the servo dog prototype so the control with respect to fabric position is open loop.

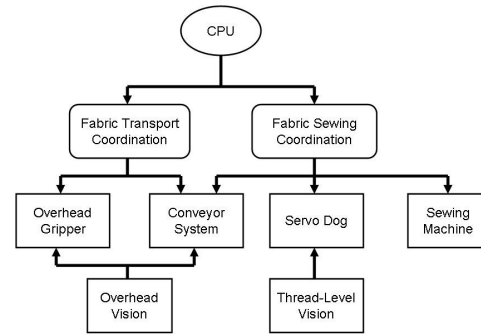

FIGURE 8 BLOCK DIAGRAM SHOWING THE CONTROL HIERARCHY OF THE AUTOMATED SEWING SYSTEM

RESULTS AND DISCUSSION

The prototype has demonstrated the ability to operate in time with the sewing machine using the IR sensor and has successfully controlled fabric through multiple trajectories while being driven by the sewing machine motor at sewing speeds.

The prototype actuator has demonstrated the capability of controlling the fabric over a closed trajectory. Two test trajectories are shown below in Figure 9 and Figure 10. The control is entirely open loop with respect to the fabric position. Attempts at following a closed trajectory have confirmed the need for feedback control of the fabric position primarily to account for fabric slip at the point of contact with the actuator. This can be seen in Figure 9 where the final straight line is not at a perfect ninety-degree angle to the vertical line and in the varied lengths of each motion although the motions were programmed to be the same length.

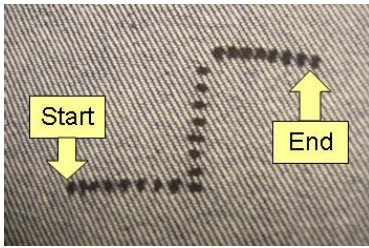

FIGURE 9 TRAJECTORY SHOWING TWO 90° TURNS, ONE LEFT AND THE NEXT RIGHT

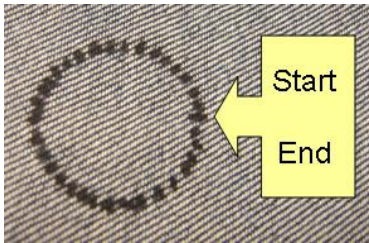

FIGURE 10 A CIRCULAR TRAJECTORY WITH THE ENDPOINT BEING THE SAME AS THE STARTING POINT

The cable drive system coupled with voice coil motors has proven to be a useful method by which to perform high acceleration tasks with multiple degrees of freedom. Measured accelerations reached approximately 27 g's, which would result in nearly 5,460 stitches per minute. No noticeable resonance has been observed over the operating frequencies as a result of the flexible cables.

Fabric control was only demonstrated over closed trajectories up to 500 stitches per minute as measured by a tachometer. This is a result of the limitations of the software used to control the system. Five commands are required to be sent to the amplifier from the PC for each motion, in addition to the commands needed to read the analog voltage from the optical sensor. Each command requires at least a 3 millisecond delay to fully process. This limits the speed at which the system can operate. The servo dog itself, in fact, is capable of much higher sewing speeds based on measured acceleration. If the computation and communication time can be reduced, then the sewing speeds could be increased.

CONCLUSION AND FUTURE WORK

This proposed method presents a novel approach to fabric control, and a prototype has demonstrated the feasibility of such a device. The use of voice coil motors with a cable drive system is an effective way to meet the needs of a high acceleration, small displacement position control system. The use of an incremental actuation method with a thread tracking vision system may finally lead to an effective means of performing automated sewing.

ACKNOWLEDGMENTS

The authors would like to thank Software Automation and One Georgia for their financial support. They would also

like to recognize Professor Sundaresan Jayaraman for his support and assistance.

REFERENCES

- [1] Koustoumpardis, P., and Aspragathos, N., 2003. "Fuzzy logic decision mechanism combined with a neuro-controller for fabric tension in robotized sewing process". *Journal of Intelligent and Robotic Systems*, 36(1), January, pp. 65-68.
- [2] Byrne, C., 1995. "Impact of new technology in the clothing industry: outlook to 2000". *Textile Outlook International*, March, pp. 111-40.
- [3] Torgerson, E., and Paul, F., 1988. "Vision guided robotic fabric manipulation for apparel manufacturing". *IEEE Control Systems Magazine*, 8(1), February, pp. 14-20.
- [4] Gershon, D., and Porat, I., 1988. "Vision servo control of a robotic sewing system". *IEEE International Conference on Robotics and Automation*, 5, April, pp. 1830-1835.
- [5] Gershon, D., 1990. "Parallel process decomposition of a dynamic manipulation task: robotic sewing". *IEEE Transactions on Robotics and Automation*, 6(3), June, pp. 357-367.
- [6] Lui, H., and Lin, H., 2008. "Sequence trajectory generation for garment handling systems". *Applied Mathematical Modeling*, 32(6), June, pp. 1017-1026.
- [7] Kondratas, A., 2005. "Robotic gripping device for garment handling operations and its adaptive control". *Fibres and Textiles in Eastern Europe*, 13(4), October, pp. 84-89.
- [8] Kolluru, R., Valavanis, K., Smith, S., and Tsourveloudis, N., 2002. "An overview of the University of Louisiana robotic gripper system project". *Transactions of the Institute of Measurement and Control*, 24(1), pp. 65-84.
- [9] Zoumponos, G., and Aspragathos, N., "Fuzzy logic path planning for the robotic placement of fabric on a work table". *Robotics and Computer-integrated Manufacturing*, 24(2), April, pp. 174-186.
- [10] Taylor, P., Monkman, G., and Taylor, G., 1988. "Electrostatic grippers for fabric handling". *Proceedings of the 1988 IEEE International Conference on Robotics and Automation*, 1, April, pp. 431-433.
- [11] Parker, J., Dubey, R., Paul, F., and Becker, R., 1983. "Robotic Fabric handling for automating garment manufacturing". *Transactions of the ASME. Journal of Engineering for Industry*, 105(1), February, pp. 21-26.