

Final Report

# DEVELOPMENT OF AN EMULATED OPERATION THERMAL CONTROL MODEL FOR SPACE STATION APPLICATION

By  
GARY SCHULTZ, JAMES J. HARRIS,  
DAVID W. HARRIS, and JOHN R. HARRIS  
General Dynamics Corporation  
Aircraft Division  
Aircraft Division

Submitted to  
National Aeronautics and Space Administration  
Langley Research Center  
Hampton, Virginia 23665

NASA Technical Office  
John F. Hall, Jr.  
Mail Stop 304

NASA CRIT 84-01-001

January 1985

GENERAL DYNAMICS CORPORATION  
AIRCRAFT DIVISION  
10000 BUCKLE CREEK DRIVE  
ATLANTA, GEORGIA 30341

Final Report  
NASA Grant NAG-1-551

DEVELOPMENT OF AN EMULATION-SIMULATION THERMAL CONTROL  
MODEL FOR SPACE STATION APPLICATION

by

James G. Hartley and Gene T. Colwell  
George W. Woodruff School of Mechanical Engineering  
Georgia Institute of Technology  
Atlanta, Georgia 30332

Submitted to

National Aeronautics and Space Administration  
Langley Research Center  
Hampton, Virginia 23665

NASA Technical Officer  
John B. Hall, Jr.  
Mail Stop 364

January 1988

## TABLE OF CONTENTS

ABSTRACT .....	1
INTRODUCTION .....	1
EVALUATION TECHNIQUES .....	4
EQUIPMENT LOOPS WITH CONDUCTIVE COLD PLATES (Subroutine CANDA1) .....	16
EQUIPMENT LOOPS WITH TWO-PHASE COLD PLATES (Subroutine CANDA2) .....	18
EQUIPMENT LOOPS WITH CAPILLARY COLD PLATES (Subroutine CANDA3).....	20
PUMPED LIQUID TRANSPORT SYSTEM (Subroutine CANDT1) .....	22
TWO-PHASE TRANSPORT SYSTEM (Subroutine CANDT2) .....	23
HIGH-CAPACITY HEAT PIPE TRANSPORT SYSTEM (Subroutine CANDT3)..	25
GENERIC HEAT PIPE RADIATOR MODEL (Subroutine CANDR1).....	26
HIGH CAPACITY HEAT PIPE RADIATOR MODEL (Subroutine CANDR2)....	29
LIQUID DROPLET RADIATOR MODEL (Subroutine CANDR3).....	38
METABOLIC LOOP (Subroutine METLOOP) .....	39
CONDUCTIVE COLD PLATE MODEL (Subroutine CCP).....	40
TWO-PHASE COLD PLATE MODEL (Subroutine TPCP).....	44
CAPILLARY COLD PLATE MODEL (Subroutine CAPCP).....	49
BUS HEAT EXCHANGER MODEL (Subroutine BUSHX).....	52
SIZING LIQUID SUPPLY AND RETURN LINES (Subroutine LIQLINE)....	54
SIZING VAPOR LINES (Subroutine VAPLINE).....	55
SUMMARY .....	58
REFERENCES .....	59
APPENDICES .....	59
APPENDIX A DATA BASE CONTENTS .....	A-1
APPENDIX B ASSESSMENT ALGORITHMS.....	B-1
APPENDIX C DEFAULT DATA BASE.....	C-1
APPENDIX D SAMPLE OUTPUT FROM TCS PROGRAM.....	D-1

## ABSTRACT

The goal of this program is to develop an improved capability for comparing various techniques for thermal management in the "Space Station". The work involves three major tasks:

- TASK I     Develop a Technology Options Data Base.
- TASK II    Complete development of a Space Station Thermal Control Technology Assessment program.
- TASK III   Develop and evaluate emulation models.

## INTRODUCTION

Current planning for the orbiting space station calls for a dual-keel configuration as shown in Figure 1. The thermal control system (TCS) for the space station is composed of a central TCS and internal thermal control systems for the modules, shown in Figure 2, as well as service facilities and attached payloads (hereinafter referred to as experimental truss and resource modules). The internal TCS may be attached to the central TCS through a thermal bus.

The central TCS is composed of a main transport system which collects waste thermal energy from each of the modules and transports it through coolant lines to the main rejection system. The main rejection system, in turn, is composed of steerable, constructable radiator elements attached to the transverse booms of the space station structure.

The waste heat loads in the modules arise from electrical and electronic equipment as well as metabolic loads in the manned modules. These equipment and metabolic loads may be collected by the central TCS or they may be transported to small radiators mounted on the body of individual modules.

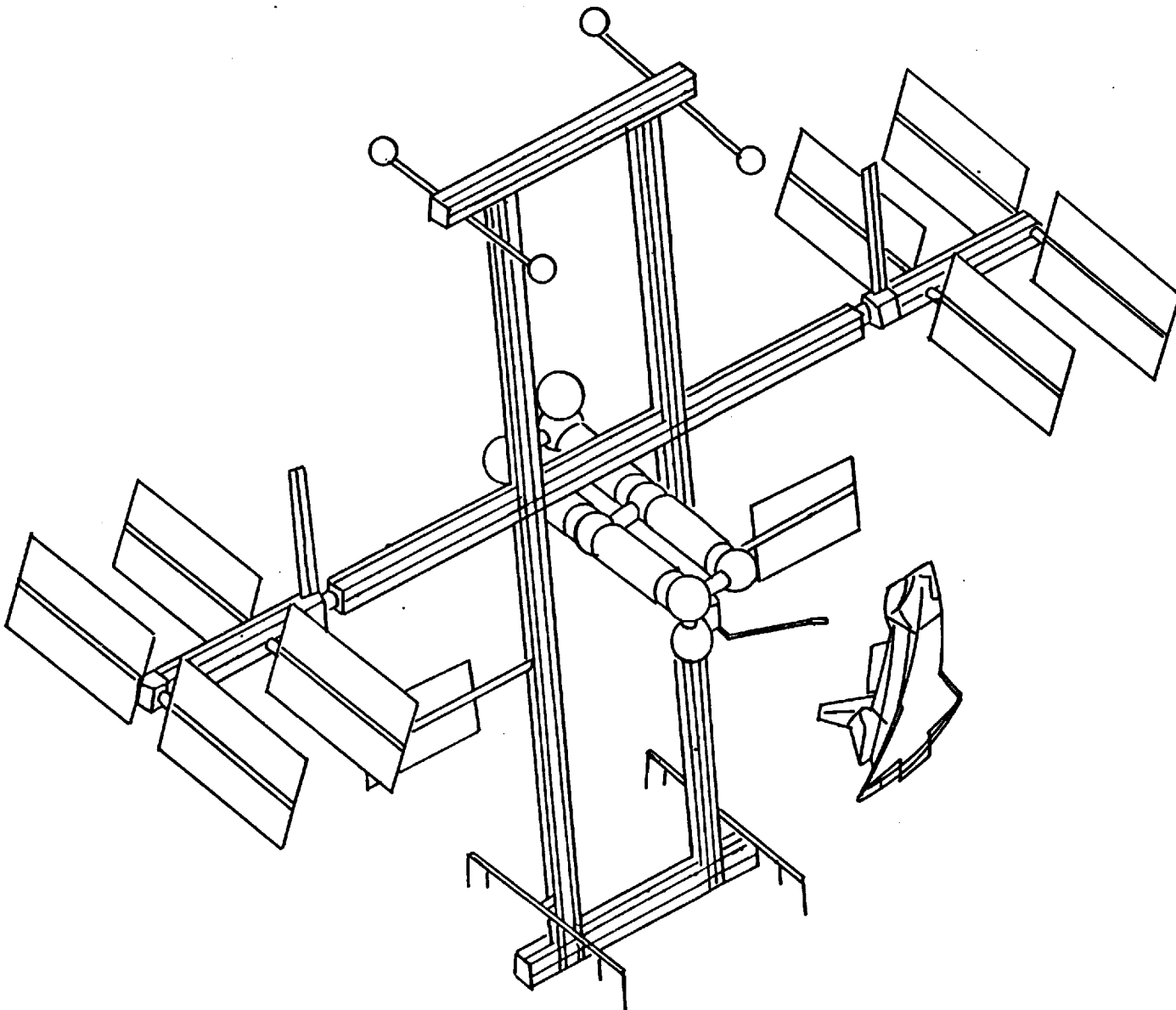

Figure 1. Space Station Configuration.

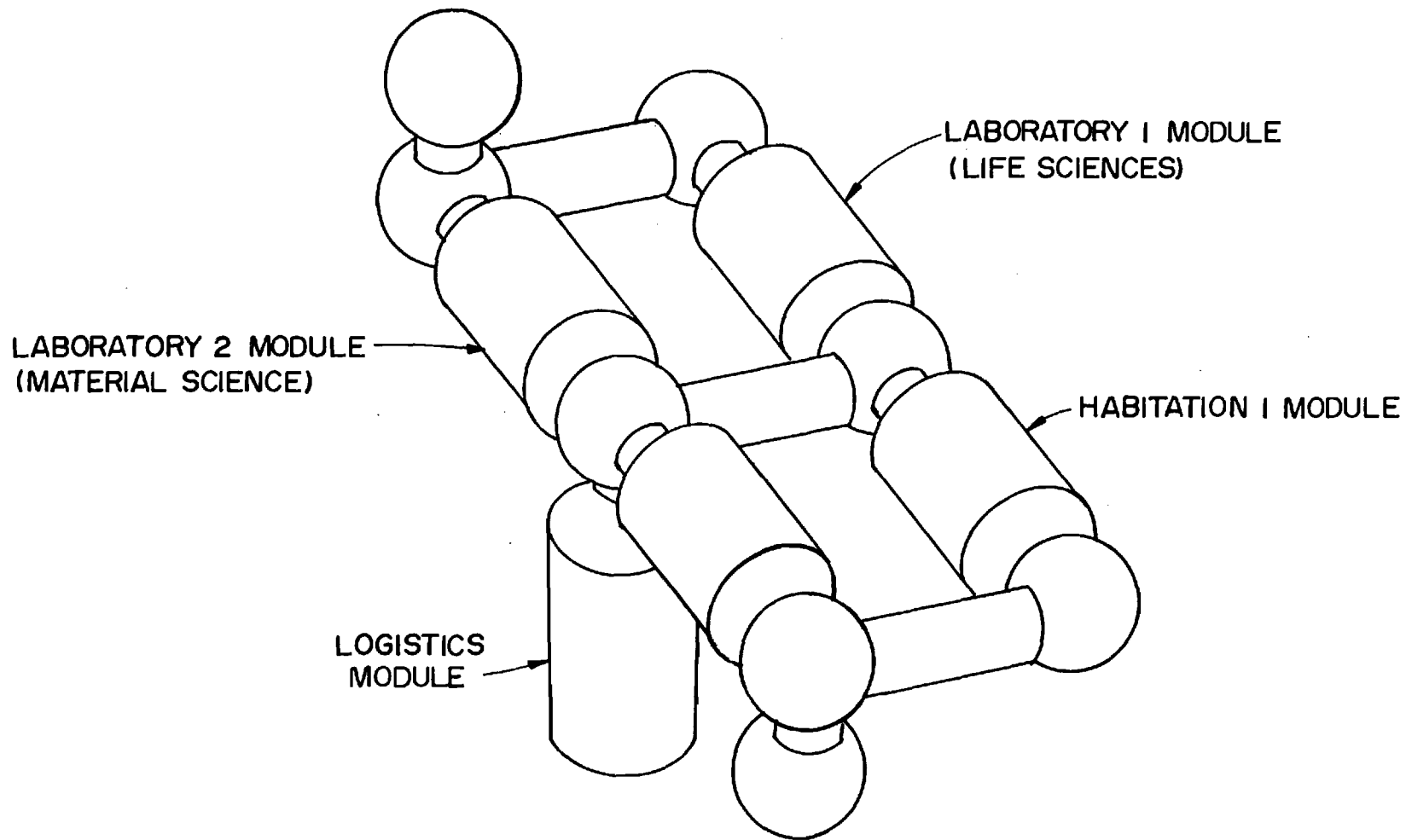

Figure 2. Station Modules.

Several candidate technologies are being considered for acquiring the waste heat loads, for transporting the thermal energy between the acquisition and rejection systems, and for rejecting the waste heat to space. The analysis techniques described here were developed for use in evaluating reliability, weights, costs, volumes, and power requirements for configurations using different candidates and different mission parameters.

### EVALUATION TECHNIQUES

The thermal control system analysis program permits the user to analyze a space station thermal control system. The space station is assumed to be composed of seven distinct modules, each of which may have its own metabolic heat loads, and equipment heat loads. In each of the modules, the user may specify the total metabolic load and the size and locations of the equipment loads. The metabolic loads are assumed to be acquired by air-water heat exchangers, transported by pumped liquid water loops, and rejected to space by body-mounted radiators attached to each of the modules which have metabolic loads. Because the metabolic loop is local to a module it is called an autonomous loop.

Heat loads generated by equipment in each module are assumed to be acquired by cold plates. The user may choose among the following candidates technologies for the cold plates in each module:

1. Conductive cold plate
2. Two-phase cold plate
3. Capillary cold plate

In addition, the user may locate up to five cold plates (each having a different capacity) in a module, choose the cold plate operating

temperature, and specify the working fluid (water, ammonia or Freon-11). The user also has the option to specify whether the equipment loop is to be integrated or autonomous. If the equipment loop is integrated, the heat from the equipment is transported from the cold plates to the main heat transport system for eventual rejection to space by the main rejection system. On the other hand, if the equipment loop is autonomous, the heat from the equipment is rejected to space by body-mounted radiators located on the module exterior. In this case the user may specify separate candidate technologies for heat transport and heat rejection in the autonomous equipment loop.

The user may select from the following candidate technologies for the main heat transport system or the heat transport system for a module having an autonomous equipment loop:

1. Pumped liquid loop
2. Pumped two-phase loop
3. High capacity heat pipe

In addition, the user may choose the transport lengths and specify the working fluid.

For the main heat rejection system or the heat rejection system for a module having an autonomous equipment loop, the user may select from the following candidate technologies:

1. Generic heat pipe radiator
2. High capacity heat pipe radiator
3. Liquid droplet radiator

In addition, the user may choose the radiator surface temperature, the emissivity and absorptivity of the radiator surface, the working fluid, and the working fluid operating temperature.

The data base for the thermal control system analysis program is divided into three major parts: the mission model parameters file, the candidate data files, and the system configuration file. Each of these are discussed in the following paragraphs. A detailed description of the data base contents is contained in Appendix A.

The mission model parameters file contains information which applies specifically to the mission or which applies to the space station as a whole. A sample mission model parameter file, as it appears to the user, is shown in Figure 3. When the program begins execution, the mission model parameter file is read from the data base. Any one or all of these parameters may be changed and used temporarily for assessment purposes or they may be replaced in the data base. In the latter instance, they become the new mission model parameter file when program execution begins anew because only the most recently saved version of the mission model parameter file is retained in the data base.

The candidate data files contain generic information for each of the candidate technologies available for heat acquisition, heat transport, and heat rejection. The data base contains one file for each candidate. A sample candidate data file, as it appears to the user, is shown in Figure 4. The weights, volumes, times and costs shown in the figure are those for the specified candidate rating. If the candidate technology is used with a different rating, these values are scaled accordingly. When the program begins execution, the candidate data files are read from the data base. Any one or all of the values in these files may be changed and used

### MISSION MODEL PARAMETERS

1.	M...MISSION DURATION, DAYS:	3650.00
2.	R...RESUPPLY INTERVAL, DAYS:	90.00
3.	NP..POWER PENALTY, LB/KW:	350.00
4.	NC..CONTROL PENALTY, LB/KW:	.00
5.	NP1.PROPULSION PENALTY, LB/KW:	60.00
6.	P...PROBABILITY OF METEROID PENETRATION, (0.920 TO 0.993):	.990
7.	CFA.TRANSPORTATION COST FACTOR, THOUSAND DOLLARS/LB:	1.60
8.	MR..MAINTENANCE COST FACTOR, THOUSAND DOLLARS/HR:	35.00
9.	IF..INTEGRATION COST FACTOR, %:	35.00
10.	PF..PROGRAMMATIC COST FACTOR, %:	70.00

Figure 3. Mission Parameters.

CANDIDATE DATA	
CANDIDATE NAME:	CONDUCTIVE COLD PLATE
1. CANDIDATE RATING, KW:	50.000
2. WEIGHT OF SPARES FOR 90 DAYS, LB:	22.100
3. VOLUME OF SPARES FOR 90 DAYS, FT3:	6.350
4. WEIGHT OF CONSUMABLES FOR 90 DAYS, LB:	.000
5. VOLUME OF CONSUMABLES FOR 90 DAYS, FT3:	.000
6. RELIABILITY (0-8):	8.000
7. TECHNOLOGY READINESS (0-8):	8.000
8. PACING TECHNOLOGY PROBLEMS (0-8):	8.000
9. 90 DAY MAINTENANCE TIME, HR:	5.000
10. NONRECURRING DESIGN, DEVELOPMENT, TEST AND CERTIFY, 1987 MILLION DOLLARS:	.600
11. SPARES AND CONSUMABLES TO OPERATE FOR 90 DAYS, 1987 MILLION DOLLARS:	.040
12. COST OF FLIGHT UNIT, 1987 MILLION DOLLARS:	.900

SELECT ONE OF THE FOLLOWING OPTIONS:

ENTER      0 - RETURN TO CANDIDATE MENU  
              1 - MODIFY CANDIDATE DATA  
              2 - REPLACE CANDIDATE DATA FILE

Figure 4. Sample Candidate Data File.

temporarily for assessment purposes or they may be replaced in the data base. In the latter instance, they become the new candidate data files when program execution begins anew because only the most recently saved versions of the candidate data files are retained in the data base.

The system configuration file is used to describe the actual thermal control system for the space station. The configuration of each module is specified by choosing the acquisition candidate (e.g. conductive cold plate) to be used to acquire the equipment load and by choosing the equipment loop to be integrated (i.e. attached to the main transport and main rejection systems) or autonomous (i.e. attached to body-mounted radiators). In addition, the user may specify the configuration data illustrated in Figure 5 for each module. Figure 6 shows a schematic of a typical configuration for an integrated module. The system configuration file also contains the layout of the main transport system. A sample transport system layout is shown in Figure 7 to illustrate the meaning of the terminology used.

Each system configuration file contains configuration details for all modules as well as specifications for the main heat transport and main heat rejection systems. A default system configuration is stored in the data base and is retrieved when the program begins execution. Any of the values in the system configuration file may be changed, and the new system configuration may be saved under a system name specified by the user. Up to 71 different system configurations can be stored in the data base at one time, and these may be recalled for later use by directing the program to retrieve a previously saved system configuration file.

- LOGISTICS MODULE
1. EQUIP LOOP: INTEGRATED
  2. ACQUISITION SUBSYSTEM: CONDUCTIVE COLD PLATE

SELECT ONE OF THE FOLLOWING OPTIONS:

- ENTER
- 0 - RETURN TO SYSTEM CONFIGURATION MENU
  - 1 - CHANGE MODULE NAME
  - 2 - CHANGE SUBSYSTEMS
  - 3 - EXAMINE SUBSYSTEM CONFIGURATIONS

LOGISTICS MODULE

ACQUISITION SUBSYSTEM: CONDUCTIVE COLD PLATE  
 TOTAL COLD PLATE CAPACITY, KW: 20.00

1. NUMBER OF COLD PLATES: 5.00
2. COLD PLATE OPERATING TEMPERATURE, C: 20.00
3. METABOLIC LOAD, KW: 2.36

	CP #1	CP #2	CP #3	CP #4	CP #5
4. HEAT REJECTION LOADS, KW:	4.00	4.00	4.00	4.00	4.00
5. MAIN SUPPLY LINE LENGTHS, FT:	8.00	4.00	4.00	4.00	4.00
6. BRANCH SUPPLY LINE LENGTHS, FT:	10.00	10.00	10.00	10.00	10.00
7. MAIN RETURN LINE LENGTHS, FT:	8.00	4.00	4.00	4.00	4.00
8. BRANCH RETURN LINE LENGTHS, FT:	10.00	10.00	10.00	10.00	10.00
9. WORKING FLUID:	AMMONIA				
10. PIPE MATERIAL:	STAINLESS STEEL				

Figure 5. Sample Module Configuration Data.

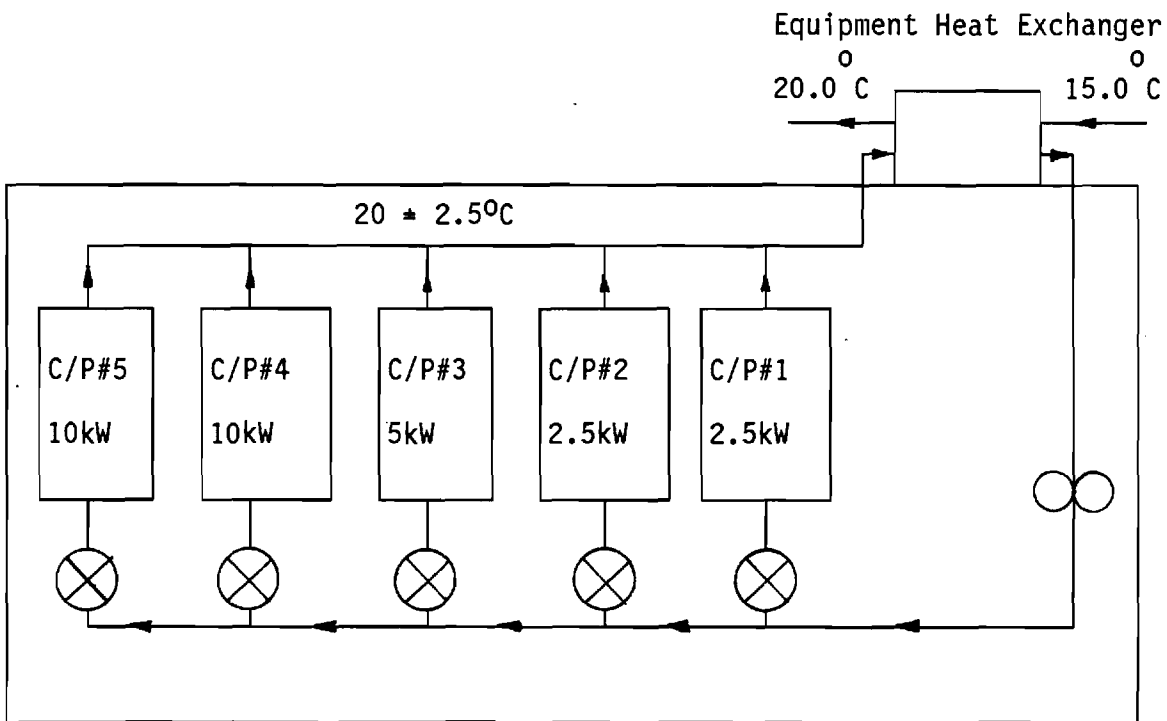

TYPICAL MODULE EQUIPMENT LOOP

Figure 6. Typical Configuration for an Integrated Module.

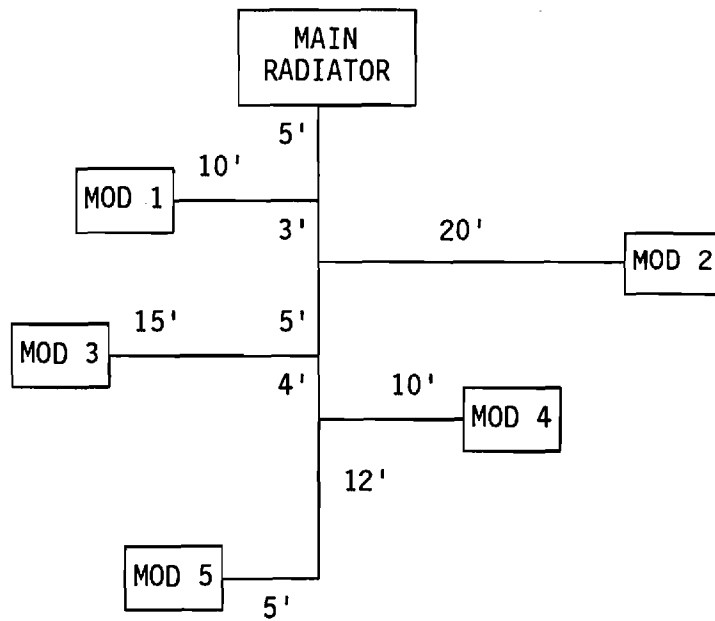

TO RADIATOR, FT:	5.00	8.00	13.00	17.00	29.00
BRANCH, FT:	10.00	20.00	15.00	10.00	5.00

Fig. 7. Sample Transport System Layout

The thermal control system analysis program uses the system configuration file, together with the mission model parameter file and the candidate data files, to assess the reliability, weight, volume and cost of the proposed thermal control system. The analysis produces the following output:

1. Acquisition assessment for each module
2. Summary acquisition assessment for all modules
3. Summary transport assessment for the main transport system
4. Summary rejection assessment for the main rejection system
5. Summary assessment for the entire thermal control system.

The analysis begins with a determination of the launch weight, launch volume, heat transfer surface areas and external power requirement imposed by the acquisition system for each module. These computations depend upon the acquisition candidate and module configuration and are performed in separate subroutines - one for each of the candidate technologies. For example, acquisition system subroutines contain algorithms for sizing coolant lines for minimum weight, determining cold plate sizes and weights, computing pumping power required, determining thermal bus connection requirements, and computing the volume occupied by the acquisition systems. These computations depend upon the candidate technology employed (i.e. single-phase or two-phase cold plates, etc.), working fluid, materials, and operating temperatures. For a rejection system candidate such as a heat pipe radiator, the candidate subroutine contains algorithms for assessing the performance of heat pipe elements which would be used to construct the radiator. In this case, parameters such as working fluid, material, radiator temperature, geometry and surface radiative properties may be selected and included in the design calculations.

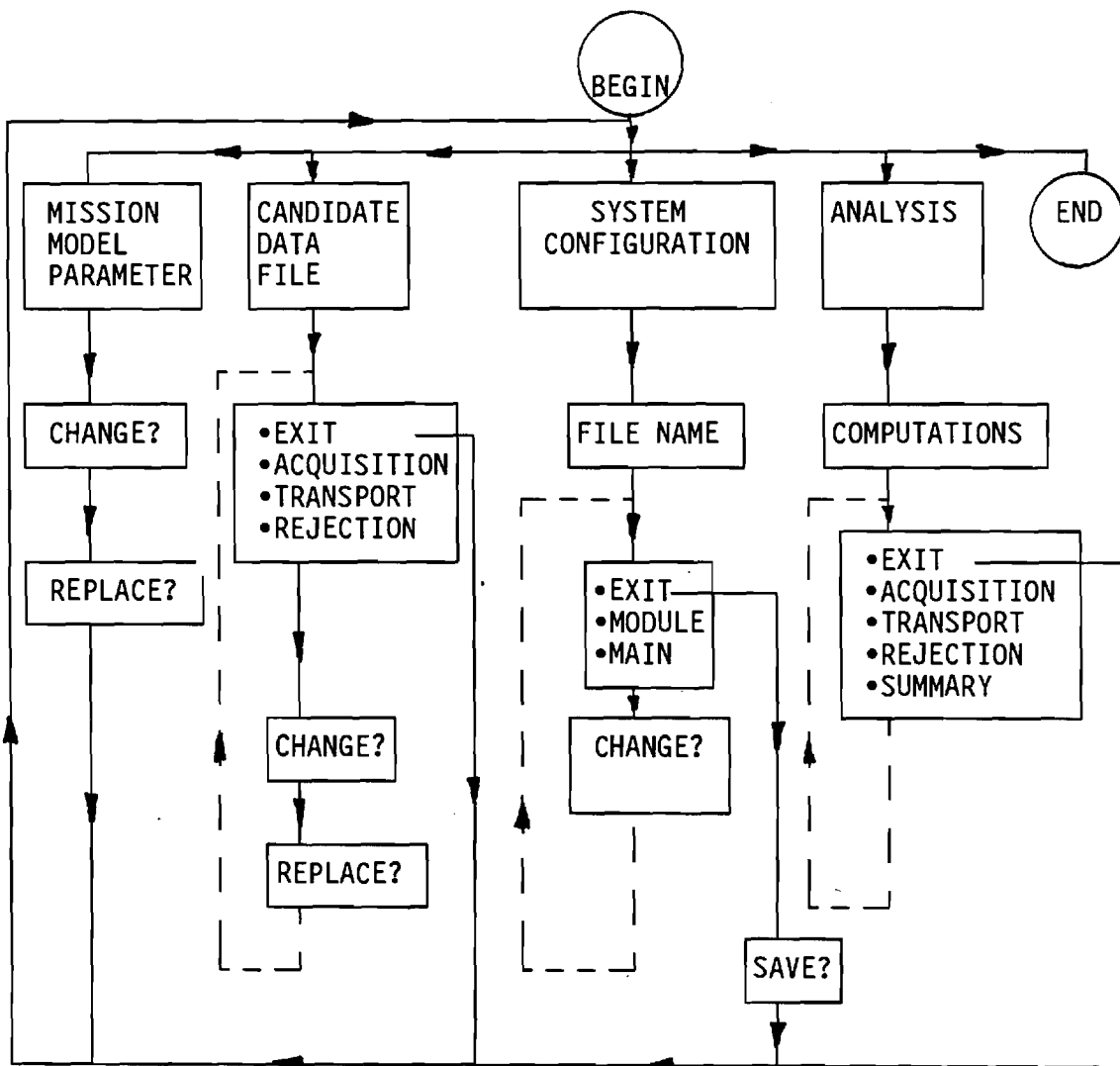

Figure 7. TCS PROGRAM SCHEMATIC

The launch weight, launch volume, surface areas and power requirement computed in the candidate subroutine, together with the mission model parameters and candidate data file, are used to compute all of the other assessment information illustrated in Appendix B. A complete set of candidate data files and samples assessment results for the DEFAULT data base (except that the habitat module is autonomous) are contained in Appendix C and D, respectively.

A flow schematic illustrating the operation of the program as the user views it is shown in Figure 8. This figure shows the main program menu and the four primary sub-menus. The sub-menus control access to the data base contents (i.e. the mission model parameters, the candidate data files, and the system configurations) and the execution of and output from the analysis portion of the program. Program flow is controlled through the main menu, and upon completion of sub-menu tasks the user always returns to the main menu. The computations that occur in the analysis phase rely on analysis models. These models are contained in separate subroutines that are described in the following paragraphs.

## EQUIPMENT LOOPS WITH CONDUCTIVE COLD PLATES (Subroutine CANDAI)

Equipment loops with conductive cold plates employ a working fluid that remains in the liquid phase. The analysis of these loops is performed in subroutine CANDAI as outlined below.

1. The metabolic loop is analyzed using subroutine METLOOP to determine the volume, mass and pump power for the metabolic loops.
2. The conductive cold plates in the equipment loop are analyzed using subroutine CCP to determine the mass flow rates through each cold plate, the mass flow rates through each segment of the liquid supply and liquid return lines, the total acquisition surface area, the total cold plate mass, and the total cold plate volume.
3. The liquid supply lines, the liquid return lines, and the branch lines are sized using subroutine LIQLINE to determine the pipe mass, the fluid mass, the piping volume, and the total pressure drop in the equipment loop. (The pressure drop through each cold plate is assumed to be 5 psi.)
4. The total pump power requirement for the equipment loop is determined in subroutine DELPRS.
5. The weight of the pump package for the equipment loop and for the metabolic loop are computed.
6. The results of these analyses are stored in the TEMP array in the following order where IMOD denotes the module number or index:

TEMP(IMOD,1) = pump power required, kW

This value includes the pump power required for the equipment loop and the pump power required by the metabolic loop.

TEMP(IMOD,2) = total mass, lb

This value includes the cold plate mass, the dry pipe mass and the fluid mass of the equipment loop, the total mass (wet pipe and heat exchanger) of the metabolic loop, and the pump package weight for the equipment loop and the metabolic loop.

TEMP(IMOD,3) = total volume, ft<sup>3</sup>

This value includes the cold plate volume, the volume of the piping in the equipment loop, and the total volume (piping and heat exchanger) of the metabolic loop.

TEMP(IMOD,4) = acquisition surface area, ft<sup>2</sup>

This value includes only the total surface area of the conductive cold plates in the equipment loop.

TEMP(IMOD,5) = total cold plate load, kW

If the equipment loop is integrated, the bus heat exchanger used to couple the equipment loop to the main transport system is considered to be a part of the main transport system. On the other hand, if the equipment loop is autonomous, the weight, volume, etc. of a bus heat exchanger and a body-mounted radiator are included in the totals for the module's equipment loop. These values, however, are computed as part of the acquisition system analysis (see the description of subroutine ACQUIS).

## EQUIPMENT LOOPS WITH TWO-PHASE COLD PLATES (Subroutine CAND2)

Equipment loops with two-phase cold plates employ a working fluid that changes phase from liquid to vapor as it passes through the cold plates. The analysis of these loops is performed in subroutine CAND2 as outlined below:

1. The metabolic loop is analyzed using subroutine METLOOP to determine the volume, mass and pump power for the metabolic loop.
2. The two-phase cold plates in the equipment loop are analyzed using subroutine TPCP to determine the mass flow rates through each cold plate, the mass flow rates through each segment of the liquid supply and vapor return lines, the total acquisition surface area, the total cold plate mass, and the total cold plate volume.
3. The liquid supply lines and the branch supply lines are sized using subroutine LIQLINE to determine the pipe mass, the fluid mass, the piping volume, and the total liquid pressure drop in the equipment loop. (The pressure drop through each cold plate is assumed to be 5 psi.)
4. The vapor return lines and the branch return lines are sized using subroutine VAPLINE to determine the pipe mass, the fluid mass, the piping volume, and the total vapor pressure drop in the equipment loop.
5. The total pump power requirement for the equipment loop is determined in subroutine DELPRS.
6. The weight of the pump package for the equipment loop and for the metabolic loop are computed,

7. The results of these analyses are stored in the TEMP array in the following order and IMOD denotes the module number of index:

TEMP(IMOD,1) = pump power required, kW

This value includes the pump power required for the equipment loop and the pump power required by the metabolic loop.

TEMP(IMOD,2) = total mass, lb

This value includes the cold plate mass, the dry pipe mass and the fluid mass of the equipment loop, the total mass (wet pipe and heat exchanger) of the metabolic loop, and the pump package weight for the equipment loop and the metabolic loop.

TEMP(IMOD,3) = total volume, ft<sup>3</sup>

This value includes the cold plate volume, the volume of the piping in the equipment loop, and the total volume (piping and heat exchanger) of the metabolic loop.

TEMP(IMOD,4) = acquisition surface area, ft<sup>2</sup>

This value includes only the total surface area of the two-phase cold plates in the equipment loop.

TEMP(IMOD,5) = total cold plate load, kW

If the equipment loop is integrated, the bus heat exchanger used to couple the equipment loop to the main transport system is considered to be a part of the main transport system. On the other hand, if the equipment loop is autonomous, the weight, volume, etc. of a bus heat exchanger and a body-mounted radiator are included in the totals for the module's equipment loop. These values, however, are computed as part of the acquisition

system analysis.

#### EQUIPMENT LOOPS WITH CAPILLARY COLD PLATES (Subroutine CAND3)

Equipment loops with capillary cold plates employ a working fluid that changes phase from liquid to vapor as it passes through the cold plates. The analysis of these loops is performed in subroutine CAND3 as outlined below:

1. The metabolic loop is analyzed using subroutine METLOOP to determine the volume, mass and pump power for the metabolic loop.
2. The capillary cold plates in the equipment loop are analyzed using subroutine CAPCP to determine the mass flow rates through each cold plate, the mass flow rates through each segment of the liquid supply and vapor return lines, the total acquisition surface area, the total cold plate mass, and the total cold plate volume.
3. The liquid supply lines and the branch supply lines are sized using subroutine LIQLINE to determine the pipe mass, the fluid mass, the piping volume, and the total liquid pressure drop in the equipment loop. (The pressure drop through each cold plate is assumed to be 5 psi.)
4. The vapor return lines and the branch return lines are sized using subroutine VAPLINE to determine the pipe mass, the fluid mass, the piping volume, and the total vapor pressure drop in the equipment loop.
5. The total pump power requirement for the equipment loop is determined in subroutine DELPRS.

6. The weight of the pump package for the equipment loop and for the metabolic loop are computed,
7. The results of these analyses are stored in the TEMP array in the following order and IMOD denotes the module number of index:

TEMP(IMOD,1) = pump power required, kW

This value includes the pump power required for the equipment loop and the pump power required by the metabolic loop.

TEMP(IMOD,2) = total mass, lb

This value includes the cold plate mass, the dry pipe mass and the fluid mass of the equipment loop, the total mass (wet pipe and heat exchanger) of the metabolic loop, and the pump package weight for the equipment loop and the metabolic loop.

TEMP(IMOD,3) = total volume, ft<sup>3</sup>

This value includes the cold plate volume, the volume of the piping in the equipment loop, and the total volume (piping and heat exchanger) of the metabolic loop.

TEMP(IMOD,4) = acquisition surface area, ft<sup>2</sup>

This value includes only the total surface area of the capillary cold plates in the equipment loop.

TEMP(IMOD,5) = total cold plate load, kW

If the equipment loop is integrated, the bus heat exchanger used to couple the equipment loop to the main transport system is considered to be a part of the main transport system. On the other hand, if the equipment loop is autonomous, the weight, volume, etc. of a bus heat exchanger and a

body-mounted radiator are included in the totals for the module's equipment loop. These values, however, are computed as part of the acquisition system analysis.

#### PUMPED LIQUID TRANSPORT SYSTEM (Subroutine CANDT1)

In the pumped liquid transport system the working fluid remains in the liquid phase throughout. Integrated modules are coupled to the transport system by bus heat exchangers, and a separate bus heat exchanger couples the main transport loop to the main radiator system. The analysis of this loop is performed in subroutine CANDT1 as outlined below:

1. The operating temperature of the transport loop is assumed to be 5°C less than the minimum working fluid temperature in any of the integrated modules.
2. The total heat load of each of the integrated modules determines the load that must be handled by each of the bus heat exchangers. With these loads as well as the working fluids used in each of the integrated modules known, subroutine BUSHX is used to analyze each bus heat exchanger to determine the volume and mass.
3. The total load carried by the transport system is the sum of each of the integrated module equipment loads. With this load and the radiator working fluid known, subroutine BUSHX is used to analyze the radiator bus heat exchanger to determine its volume and mass.
4. The liquid supply lines, the liquid return lines, and the branch lines to the modules are sized using subroutine LIQLINE to determine the pipe mass, the fluid mass, the

pipng volume, and the liquid pressure drop in the transport loop. (The pressure drop through each bus heat exchanger is assumed to be 5 psi.)

5. The total pump power requirement for the transport loop is determined in subroutine DELPRS.
6. The weight of the pump package for the transport loop is computed.
7. The results of these analyses are stored in the TEMP array in the following order and the first index of the array denotes the transport systems:

TEMP(8,1) = pump power required, kW

TEMP(8,2) = total mass, lb

This value includes the mass of all bus heat exchangers, the dry pipe mass and the fluid mass of the transport loop, and the pump package weight for the transport loop.

TEMP(8,3) = total volume, ft<sup>3</sup>

This value includes the volume of all bus heat exchangers, and the volume of the piping in the transport loop.

TEMP(8,5) = total transport system load, kW

#### TWO-PHASE TRANSPORT SYSTEM (Subroutine CANDT2)

In the two-phase transport system the working fluid changes phase as it passes through the bus heat exchangers. Integrated modules are coupled to the transport system by bus heat exchangers, and a separate bus heat exchanger couples the main transport loop to the main radiator system. The analysis of this loop is performed in subroutine CANDT2 as outlined below:

1. The operating temperature of the transport loop is assumed to be 5°C less than the minimum working fluid temperature in any of the integrated modules.
2. The total heat load of each of the integrated modules determines the load that must be handled by each of the bus heat exchangers. With these loads as well as the working fluids used in each of the integrated modules known, subroutine BUSHX is used to analyze each bus heat exchanger to determine the volume and mass of each.
3. The total load carried by the transport system is the sum of each of the integrated module equipment loads. With this load and the radiator working fluid known, subroutine BUSHX is used to analyze the radiator bus heat exchanger to determine its volume and mass.
4. The liquid supply lines and the liquid branch lines to the modules are sized using subroutine LIQLINE to determine the pipe mass, the fluid mass, the piping volume, and the liquid pressure drop in the transport loop. (The pressure drop through each bus heat exchanger is assumed to be 5 psi.)
5. The vapor return lines and the vapor branch lines from the modules are sized using subroutine VAPLINE to determine the pipe mass, the fluid mass, the piping volume, and the vapor pressure drop in the transport loop.
6. The total pump power requirement for the transport loop is determined in subroutine DELPRS.
7. The weight of the pump package for the transport loop is computed.

8. The results of these analyses are stored in the TEMP array in the following order and the first index of the array denotes the transport systems:

TEMP(8,1) = pump power required, kW

TEMP(8,2) = total mass, lb

This value includes the mass of all bus heat exchangers, the dry pipe mass and the fluid mass of the transport loop, and the pump package weight for the transport loop.

TEMP(8,3) = total volume, ft<sup>3</sup>

This value includes the volume of all bus heat exchangers, and the volume of the piping in the transport loop.

TEMP(8,5) = total transport system load, kW

#### HIGH-CAPACITY HEAT PIPE TRANSPORT SYSTEM (Subroutine CANDT3)

The high-capacity heat pipe transport system is not likely to be serious transport candidate for the orbiting space station. For this reason the linear assessment model contained in the original NASA assessment program has been retained in the present program.

The linear model consists of the following:

1. The pump power is zero.
2. The total mass of a 50-kW system is assumed to be 2250 lb, and the total mass for other system sizes is scaled linearly.
3. The total volume of a 50-kW system is assumed to be 7.15 ft<sup>3</sup>, and the total volume for other system sizes is scaled linearly.

4. The results for this model are stored in the TEMP array in the following order and the first index of the array denotes the transport systems:

TEMP(8,1) = pump power required, kW

TEMP(8,2) = total mass, lb

TEMP(8,3) = total volume, ft<sup>3</sup>

TEMP(8,5) = total transport system load, kW

#### GENERIC HEAT PIPE RADIATOR MODEL (Subroutine CANDR1)

The performance of a variety of heat pipe radiators can be predicted by means of a generic heat pipe radiator model. To use the model, a set of operating conditions derived from actual experimental measurements or detailed model predictions must be provided. These conditions are called base design data and are supplied by the user to the TCS program through interaction with the candidate data file for the generic heat pipe radiator.

Because the actual construction and geometry of a radiator panel may differ greatly from one design to another, the generic heat pipe radiator model incorporates two main assumptions. The first is that the base design data is known and the second is that for all operating conditions the internal and external geometry of the heat pipe panel remain the same.

With these restrictions, the design heat transport for the heat pipe (assumed to be approximately one-half of the capillary limited heat transfer rate) is proportional to the heat pipe number.

$$\dot{Q}_D = C_D N$$

where  $C_D$  is a constant determined by the heat pipe geometry, and  $N$  is the

heat pipe number whose value depends upon the working fluid and the operating temperature of the working fluid.

Furthermore, the rate at which heat is rejected by the radiator surface is determined from

$$\dot{Q} = \frac{C_R \epsilon A T^4}{F_a}$$

where  $\epsilon$  is the emissivity of the radiator surface,  $A$  is the radiator surface area,  $T$  is the absolute temperature of the radiator surface, and  $F_a = 1 + 0.5 (a_s - 0.20)$ , adapted from reference [7] page 525. The absorptivity of the radiator surface is  $a_s$ .

The base design data, denoted by subscript 1, needed for this model consists of the following (the values in parentheses represent the default values stored in TCS program):

$Q_{D1}$ =	heat rejected per panel, kW	(1.0)
$A_p$ =	surface area per panel, ft <sup>2</sup>	(50.0)
$W_p$ =	weight per panel, lbm	(52.1)
$V_p$ =	volume per panel, ft <sup>3</sup>	(3.12)
$c_p$ =	cost per panel, k\$	(20.0)
$L_c$ =	condenser length, ft	(47.5)
$L_e$ =	evaporator length, ft	(2.5)
$a_{s1}$ =	absorptivity of radiator surface	(0.3)
$\epsilon_1$ =	emissivity of radiator surface	(0.78)
$T_1$ =	radiator surface temperature, °C	(24.0)
$T_{f1}$ =	working fluid temperature, °C	(37.0)
Working fluid		(Ammonia)

With the base design data (subscript 1) available, the following equations are used to predict performance of the radiator panel for different operating conditions and working fluids (subscript 2):

1. Design Heat Transport Per Panel

$$\dot{Q}_{D2} = \dot{Q}_{D1} N_2/N_1$$

2. Number of Panels (based upon design heat transport)

$$N_{PD} = \dot{Q}_2 / \dot{Q}_{D2}$$

3. Number of Panels (based upon radiator surface heat rejection capacity)

$$N_{PR} = \frac{A_2}{A_1} = \frac{\dot{Q}_2 F_{a2} \epsilon_1}{\dot{Q}_1 F_{a1} \epsilon_2} \left( \frac{T_1}{T_2} \right)^4$$

4. Number of Panels Required

The number of panels required for the new operating conditions depends upon whether the radiator capacity is limited by heat pipe transport or by the heat rejection capacity of the radiator. Thus

$$N_p = \text{Maximum } (N_{PD}, N_{PR})$$

5. Total Radiator Weight (excluding heat exchangers)

$$W_R = N_p W_p$$

6. Total Radiator Volume

$$V_R = N_p V_p$$

7. The results of the analysis are stored in the TEMP array in the following order and the first index of the array denotes the rejection system:

TEMP(9,1) = pump power required, kW (zero)

TEMP(9,2) = total mass, lb

This value includes the mass of the radiator system only.

TEMP(9,3) = total volume, ft<sup>3</sup>

This value includes the volume of the radiator system only.

TEMP(9,5) = total rejection system load, kW

These equations have been incorporated into CANDR2 in the thermal control system analysis program.

#### **HIGH CAPACITY HEAT PIPE RADIATOR MODEL (Subroutine CANDR2)**

A high performance heat pipe radiator using a series of heat pipes with combination slab and circumferential capillary structure is modeled for space station use in the temperature range of 310 K to 366 K (100°F to 200°F). A schematic of the capillary structure is shown in Figure 9. Axial transport of working fluid primarily occurs through the central slab while the circumferential structure distributes the fluid around the circumference in the heated and cooled sections.

Performances of various heat pipes to be used in a radiator panel are estimated from experimental studies performed at Georgia Tech, Reference [7] on a Refrigerant-11 heat pipe with slab capillary structure. This heat pipe can transport a maximum thermal energy of about 130 watts at 440 K when operating with Refrigerant-11 as a working fluid. Heat pipes to be

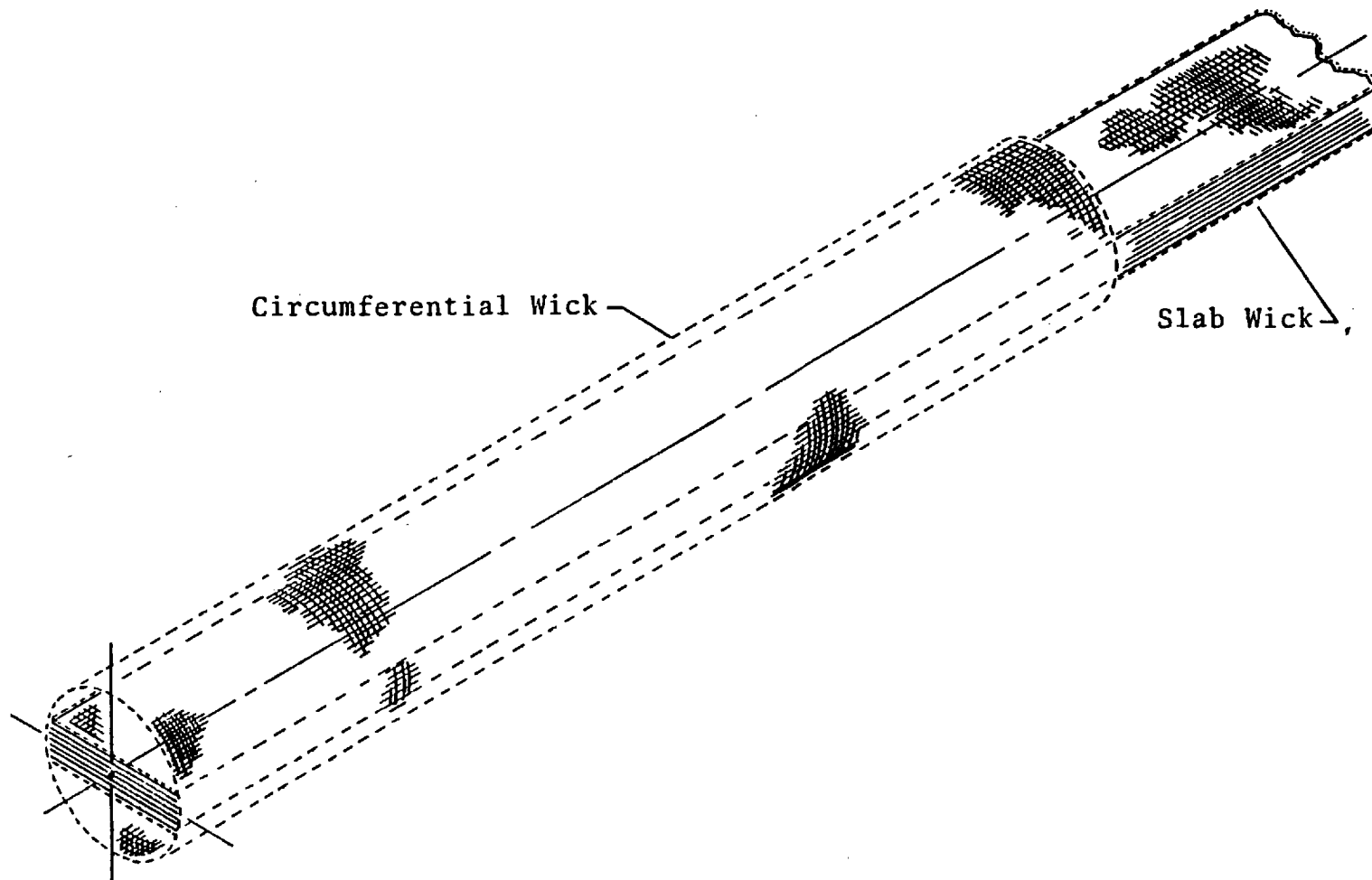

Figure 9. Close-Up of Composite Slab and Circumferential Wick at Heat Transfer Section

used in a radiator for the space station may use other working fluids, may utilize different capillary structures, may be of different outside diameter and (or) length and may operate at different temperatures. All of these design parameters greatly affect heat pipe thermal transport capacity.

Writing momentum, energy and continuity equations for steady operation of the mold heat pipe at capillary limited heat transfer and making the standard simplifying assumptions the following equation, from reference [8], is obtained.

$$\dot{Q}_{CL} = \frac{2N/r_p}{\frac{\bar{K}L_{eff}}{b\delta_T} + \frac{K_{CL}}{4n_C\delta_C} \left[ \frac{1}{L_e} + \frac{1}{L_c} \right] + \frac{8\mu_V\rho_L L_{eff}}{\pi\mu_L\rho_V r_p^4}}$$

where

$\dot{Q}_{CL}$  = Capillary limited heat transfer rate

$N = \frac{\sigma h_{fg}\rho_L}{\mu_L}$  = "Heat Pipe Number"

$\sigma$  = surface tension of liquid  
 $h_{fg}$  = heat of vaporization

$\rho_L, \rho_V$  = liquid density

$\mu_L, \mu_V$  = liquid dynamic viscosity

$r_p$  = pore radius at evaporator surface

$\bar{K} = \frac{\delta_T}{\frac{n_A\delta_A}{K_A} + \frac{n_B\delta_B}{K_B}}$  = effective inverse permeability  
 for slab based on approach velocity.

$\delta_T$  = total thickness of slab

$n_A$  = number of layers of fine mesh in slab

- $n_B$  = number of layers of coarse mesh in slab  
 $\delta_A$  = thickness of a single layer of material A  
 $\delta_B$  = thickness of a single layer of material B  
 $K_A$  = inverse permeability for material A based on approach velocity  
 $K_B$  = inverse permeability for material B based on approach velocity  
 $L_{eff}$  = effective length of liquid path in slab  
 $b$  = width of slab  
 $K_C$  = inverse permeability for material at evaporator and condenser surfaces based on approach velocity  
 $L$  = average distance traveled by liquid in circumferential capillary structure at evaporator or condenser (approximately 45° arc)  
 $n_C$  = number of layers of capillary material on circumference  
 $\delta_C$  = thickness of a single layer of material C  
 $L_e$  = axial length of evaporator section  
 $L_c$  = axial length of condenser section  
 $r_v$  = hydraulic radius of vapor space

The three terms in the denominator of this equation are related to flow resistance in the central slab, the circumferential capillary structure and the vapor region, respectively. For the present design, flow resistance is much larger in the slab than in the circumferential structure or in the vapor region. Thus, approximately

$$\dot{Q}_{CL} \approx \frac{2N b \delta_T}{r_p \bar{K} L_{eff}}$$

Design heat transport capability is assumed to be one-half of maximum transport capability.

$$\dot{Q}_D = \dot{Q}_{CL}/2 = \frac{Nb\delta_T}{r_p \bar{K} L_{eff}}$$

The based design parameters for the heat pipe radiator are shown in Table 1, and Figure 10 shows a radiator constructed from a series of 50 foot heat pipes and fin panels. Assuming each heat pipe is 3/4-in. outside diameter and 5/8-in. inside diameter and 50 feet long the metal weight will be about 8 lbm and the working fluid will weigh about 1.5 lbm for a total weight of 9.5 lbm per pipe. The fin thickness is taken to be 1/16 in.

The following equations are used to predict areas and weights for a particular candidate from known values for the base design.

1. Design Heat Transport Per Pipe

$$\dot{Q}_{D_2} = \dot{Q}_{D_1} \frac{N_2}{N_1} \frac{\bar{K}_1}{\bar{K}_2} \frac{r_{p1}}{r_{p2}} \frac{L_{eff,1}}{L_{eff,2}} \frac{\delta_{T_2}}{\delta_{T_1}}$$

where subscript 1 refers to the base case of known performance and subscript 2 refers to the new design whose performance is to be computed, respectively.

2. Number of Panels

$$N_p = \frac{\dot{Q}}{\dot{Q}_{D_2}}$$

where  $\dot{Q}$  is the actual heat rejection load (kW) of the radiator

TABLE 1. Heat Pipe Base Design - Georgia Tech Heat Pipe.

Parameters	Values
Rating, $\dot{Q}_1$	50 kW
Area, $A_1$	2500 ft <sup>2</sup> - reference [8]
Radiator surface temperature, $T_1$	297 K
Material	aluminum
Heat pipe I.D.	0.625 in.
Heat pipe O.D.	0.75 in.
Fin thickness	0.0625 in.
Heat pipe length	50 ft.
Evaporator length	2.5 ft.
Condenser length	47.5 ft.
Working fluid	ammonia
Working fluid temperature	310 K
Design heat transfer per pipe, $\dot{Q}_{DL}$	1.02 kW
Number of panels	50
Panel width per pipe	12.24 in.
Capillary structure - 2 layers 400 mesh on circumference, 4 layers 400 mesh + 5 layers 30 mesh in slab.	
Weight per panel	52.1 lbm
Total radiator weight (exclusive of heat exchanger)	2,605 lbm
Radiator volume (exclusive of heat exchanger)	156 ft <sup>3</sup>
Absorptivity, $\alpha_s$	0.30
Emissivity, $\epsilon$	0.78
Ratio $\alpha_s/\epsilon$	0.385
Effective inverse permeability of slab, $\bar{K}_I$	$0.696 \times 10^9$ (1/m <sup>2</sup> )
Pore radius at evaporator, $r_{F_1}$	$1.91 \times 10^{-5}$ m
Heat pipe effective length, $L_{eff,1}$	25 ft
Heat pipe number, $N_1$	$5.6 \times 10^{10}$ W/m <sup>2</sup>
Slab total thickness, $\delta_{T_1}$	$3.41 \times 10^{-3}$ m

### 3. Radiator Surface Area

$$\frac{A_2}{A_1} = \frac{\dot{Q}_2}{\dot{Q}_1} \frac{\epsilon_1}{\epsilon_2} \frac{F_{a2}}{F_{a1}} \left[ \frac{T_1}{T_2} \right]^4$$

where

$$F_a = 1 + 0.5 (\alpha_s - 0.20), \text{ adapted from reference [7] page 525}$$

and

$$F_{aI} = 1 + 0.5 (0.30 - 0.20) = 1.05$$

### 4. Radiator Width

Assuming a length of 50 ft. for each panel, the radiator total width is given by

$$W_R(\text{ft}) = \frac{A_2(\text{ft}^2)}{50}$$

### 5. Width Per Panel

$$W_p(\text{ft}) = \frac{W_R(\text{ft})}{N_p}$$

### 6. Weight Per Panel

$$m_p(\text{lbm}) = 0.0217 \rho_m [12 W_R - N_p (0.75)] / N_p + 1.5 + \rho_m / 21.8$$

### 7. Total Radiator Weight (excluding heat exchangers)

$$m_R(\text{lbm}) = m_p N_p$$

8. Total Radiator Volume

$$V_R(\text{ft}^3) = 3.125 W_R$$

9. The results of the analysis are stored in the TEMP array in the following order and the first index of the array denotes the rejection systems:

TEMP(9,1) = pump power required, kW (zero)

TEMP(9,2) = total mass, lb

This value includes the mass of the radiator system only.

TEMP(9,3) = total volume, ft<sup>3</sup>

This value includes the volume of the radiator system only.

TEMP(9,5) = total rejection system load, kW

These equations have been incorporated into subroutine CANDR2 in the thermal control system analysis program.

Table 2 shows the results of choosing among several different working fluids and working fluid temperatures. Design heat transfer per pipe (taken to be one half of capillary limitation) ranges between about 1 kW for ammonia at 310 K to about 0.18 kW for R-11 at 366 K. While total radiator weight varies between 2,580 lbm for ammonia at 310 K to 4,090 lbm for R-11 at 366 K.

TABLE 2. HEAT PIPE RADIATOR DESIGN RESULTS

Parameter	Heat Pipe Working Fluid and Temperature							
	R-11 310 K	R-11 366 K	Methanol 310 K	Methanol 366 K	Ammonia 310 K	Ammonia 366 K	Acetone 310 K	Acetone 366 K
$\dot{Q}_{CL}$ (kW)	0.440	0.367	1.54	1.61	2.03	0.660	1.10	0.918
$\dot{Q}_D$ (kW)	0.220	0.184	0.770	0.805	1.015	0.330	0.550	0.459
Number of Pipes for 50 kW	229	275	65	62	49	153	92	110
Panel Width Per Pipe (in)	2.62	2.18	9.23	9.68	12.24	3.92	6.52	5.45
Weight Per Panel (lbm)	16.5	14.9	41.3	43.0	52.6	21.4	31.1	27.1
Total Radiator Weight (lbm)	3,780	4,090	2,690	2,660	2,580	3,270	2,870	2,990
Radiator Volume (ft <sup>3</sup> )	156	156	156	156	156	156	156	156

### LIQUID DROPLET RADIATOR MODEL (Subroutine CANDR3)

Liquid droplet and liquid sheet radiators have been under development for several years (References 12-14). With the liquid droplet radiator concept, a working fluid is heated in a heat exchanger, emitted by a droplet generator, collected by a collector, and circulated back to the heat exchanger by a pump. Individual droplets (or a thin sheet of droplets) radiate energy to space with little loss of mass since fluids with vapor pressures of about  $10^{-9}$  torr at the working temperature are chosen.

The possible advantages of a liquid droplet (or liquid sheet) radiator over a high-capacity heat pipe radiator include low weight, ease of deployment, compact storage during transport, little or no damage by micrometeoroid penetration, and compact size for large power systems (kilowatt and megawatt ranges). On the other hand, expected disadvantages include spacecraft contamination owing to working fluid loss and difficulty in obtaining high emissivities with liquid droplets.

Working fluids of interest are Dow Corning Heat Transfer Fluid, NaK, Li, and Al. For example, a 200-watt radiator operating at 300 K might use NaK as a working fluid and could potentially weigh one-fifth to one-tenth as much as a high-capacity heat pipe radiator for such an application.

Based on work to date on development of liquid droplet and liquid sheet radiators, the feasibility of such devices appears to be good for many space-radiating applications. However, insufficient information is available to implement a realistic assessment algorithm in the computer program at this time. Although a subroutine appears in the program listing, the routine returns zero values for the pump power, total mass,

and total volume. This subroutine may be modified appropriately as engineering data become available.

#### METABOLIC LOOP (Subroutine METLOOP)

The metabolic loop is assumed to be composed of a single, pumped liquid water loop operating at 25°C. An air/water heat exchanger is used to cool the cabin air and the heat is rejected at each module by a body-mounted radiator.

The mass flow rate of water is determined from the metabolic load assuming that the water experiences a 20°C increase in temperature as it passes through the heat exchanger. The volume of the air/water heat exchanger is sized by assuming that 1 ft<sup>3</sup> is required for each 2.36 kW of metabolic load, and the mass of the heat exchanger is assumed to be 4.92 lb/kw.

The liquid line for the metabolic loop is sized using subroutine LIQLINE, which also computes the wet and dry line weights and the fluid pressure drop. The pump power required is computed in subroutine DELPRS.

The volume and weight of the bus heat exchanger, which couples the metabolic loop to the body-mounted radiator, are determined in subroutine BUSHX. The volume and weight of the radiator are computed in subroutine CANDRI (heat pipe radiator analysis).

The mass computed in METLOOP consists of the air/water heat exchanger mass, the bus heat exchanger mass, and the wet mass of the pipe. The volume is determined from the sum of the volumes of each of these components.

### CONDUCTIVE COLD PLATE MODEL (Subroutine CCP)

The conductive cold plate is assumed to have an equipment mounting face of length  $L$  and width  $W$ . The cold plate has  $n$  channels for liquid flow, each of which has a hydraulic diameter of  $D_H$ . The power,  $Q$ , dissipated by the equipment mounted on the cold plate is assumed to be uniformly distributed over the surface of the cold plate. The cooling fluid enters the cold plate at temperature  $T_i$  and leaves at temperature  $T_o$ . The cold plate operating temperature is  $T_p$ , and  $T_f$  is the average temperature of the fluid in the cold plate. The temperature difference  $(T_p - T_f)$  is assumed to be the same for all operating conditions.

The total mass flow rate,  $\dot{m}$ , of fluid in the cold plate is computed from the following expression:

$$\dot{m} = \frac{Q}{c_p (T_o - T_i)} \quad (1)$$

The temperature difference  $(T_o - T_i)$  is assumed to be the same for all operating conditions.

For a specific cold plate design, the ratio of the plate surface area to the internal wetted perimeter is assumed to be constant, i.e.

$$\frac{A_o}{n\pi D_H L} = \text{constant} \quad (2)$$

and the hydraulic diameter and length of each flow passage are assumed to be fixed. The fluid flow through the internal channels is assumed to be turbulent, and the inside convective heat transfer coefficient is

determined by [1]

$$h = \frac{0.023 f(T) v^{0.8}}{D_H^{0.2}} \quad (3)$$

where  $f(T)$  accounts for the temperature dependence of the fluid properties:

$$f(T) = \frac{k^{0.67} (\rho c)^{0.33}}{\nu^{0.47}}$$

Furthermore, the mass flow rate is related to the fluid velocity through the continuity equation:

$$\dot{m} = \frac{\rho n \pi D_H^2 v}{4} \quad (4)$$

where  $n$  is the number of parallel passages, or internal channels, in the cold plate. The heat flux at the cold plate surface is computed from

$$q'' = \frac{Q}{A_o} \quad (5)$$

where  $A_o$  is the area of the mounting surface. The heat flux is also related to the difference between the cold plate surface temperature and the average fluid temperature by the expression

$$q'' = \frac{U_i n \pi D_H L (T_p - T_f)}{A_o} \quad (6)$$

where  $U_i$  is the overall heat transfer coefficient based on the inside surface area of a single flow passage. This coefficient is computed as

$$U_i = \left[ \frac{1}{h} + \frac{\delta}{k_m} \right]^{-1}$$

where  $\delta$  is a characteristic path length for conduction through the cold plate material from the interior wall of the flow passage to the cold plate external surface. Equations (1) through (6) can be written in the following dimensionless forms with the aid of reference values, denoted by the superscript \*, which are determined from a specific set of design conditions:

$$\frac{\dot{m}}{\dot{m}^*} = \frac{Q c_p}{Q^* c_p^*} \quad (8)$$

$$\frac{A_o}{A_o^*} = \frac{n}{n^*} \quad (9)$$

$$\frac{h}{h^*} = \frac{f(T)}{f(T^*)} \left[ \frac{V}{V^*} \right]^{0.8} \quad (10)$$

$$\frac{\dot{m}}{\dot{m}^*} = \frac{\rho V n}{\rho^* V^* n^*} \quad (11)$$

$$\frac{q''}{q''^*} = \frac{Q A_o}{Q^* A_o^*} \quad (12)$$

$$\frac{q''}{q''^*} = \frac{U_i}{U_i^*} \quad (13)$$

In these equations, parameters without a superscript are those for the new set of operating conditions. Next, equations (8) through (13) can be combined to produce the following transcendental equation for the velocity of the fluid through each flow passage.

$$V = \frac{\rho^* c_p^* V^*}{\rho c_p U_i \left[ \frac{f(T^*)}{h^* f(T)} \left[ \frac{V^*}{V} \right]^{0.8} + \frac{\delta}{k_m} \right]} \quad (14)$$

With the fluid velocity known, the overall heat transfer coefficient can be computed from

$$U_i = U_i^* \frac{\rho c_p V}{\rho^* c_p^* V^*}$$

This expression is obtained by combining Eqs.(8), (9) and (11) through (13). Next the surface heat flux can be determined from Eq. (13), and the heat transfer surface area required for the new operating conditions can be computed from Eq. (5). Because the ratio of the plate surface area to the internal wetted perimeter is assumed constant, the ratio of the cold plate volume to the plate surface area is also assumed constant,

$$\frac{VOL}{A_0} = \text{constant} = c_1 \quad (15)$$

Thus, the volume can be determined once the surface area is known. In addition, the weight of the cold plate is directly proportional to the cold plate volume and the density of the cold plate material

$$W = c_2 \rho_m VOL = c_1 c_2 \rho_m A_0 \quad (16)$$

By combining Eqs. (15) and (16), we obtain an expression for the weight of the cold plate in terms of surface area,

$$W = A_o \left[ \frac{W^*}{A_o^*} \right] \left[ \frac{\rho_m}{\rho_m^*} \right] \quad (17)$$

The analysis presented here is incorporated in subroutine CCP, and the reference values for this analysis are listed in Table 3.

#### TWO-PHASE COLD PLATE MODEL (Subroutine TPCP)

The two-phase cold plate is assumed to have an equipment mounting face of length  $L$  and width  $W$ . The cold plate has  $n$  channels for fluid flow, each of which has a hydraulic diameter of  $D_H$ . The power,  $Q$ , dissipated by the equipment mounted on the cold plate is assumed to be uniformly distributed over the surface of the cold plate. The cooling fluid enters the cold plate as a saturated liquid at temperature  $T_f$  and leaves at temperature  $T_p$  with a quality of  $X$ . The cold plate operating temperature is  $T_p$ , and the temperature difference  $(T_p - T_f)$  is assumed to be the same for all operating conditions. The total mass flow rate,  $\dot{m}$ , of fluid in the cold plate is computed from the following expression:

$$\dot{m} = \frac{Q}{X h_{fg}} \quad (1)$$

The quality at the exit is assumed to be the same for all operating conditions. For a specific cold plate design, the ratio of the plate

TABLE 3. Reference Design Values for Conductive Cold Plate Analysis.

<u>Variable</u>		<u>Value</u>	<u>Reference</u>
$Q^*$		10 kW	
$q^{**}$	QPR	0.27 kW/ft <sup>2</sup>	2
$\dot{m}^*$	DOTMR	1.0542 lb/s	
$U_i^*$	UR	298.7 Btu/hr-ft <sup>2</sup> -°F (computed)	
$V^*$	VR	0.387 m/s	
$T^*$	TR	20°C	2
$(T_o - T_i)$	DELT	9°F	2
$h^*$	HR	364 Btu/hr-ft <sup>2</sup> -°F	
$\delta$	DELTA	0.005 ft	
$C_1$	C1	0.0292 ft	
$W^*/A^*$	WPA	5.3 lb/ft <sup>2</sup>	2
Fluid*	FLUIDR	water	
material*	PMATLR	Stainless steel	
$\rho_m^*, k_m^*$	DENSR, CONDR	evaluated for material*	
$\rho^*, c_p^*, \nu^*, k^*$		evaluated for fluid* at T*	

surface area to the internal wetted perimeter is assumed to be constant, i.e.

$$\frac{A_0}{n\pi D_H L} = \text{constant} \quad (2)$$

and the hydraulic diameter and length of each flow passage are assumed to be fixed. The inside convective heat transfer coefficient is determined by [1]

$$h = 9.0 \times 10^{-4} f(T) G \quad (3)$$

where the mass flux,  $G$ , is determined from

$$G = \frac{4 \dot{m}}{n\pi D_H^2} \quad (4)$$

$n$  is the number of parallel passages, or internal channels, in the cold plate, and  $f(T)$  accounts for the temperature dependence of the fluid properties:

$$f(T) = \frac{k_l k_f^{1/2}}{\mu_l}$$

where  $K_f$  is the boiling number defined as

$$K_f = \frac{X h_{fg}}{gL}$$

The heat flux at the cold plate surface is computed from

$$q'' = \frac{Q}{A_0} \quad (5)$$

where  $A_0$  is the area of the mounting surface. The heat flux is also related to the difference between the plate surface temperature and the

average fluid temperature by the expression

$$q'' = \frac{U_i n \pi D_H L (T_p - T_f)}{A_o} \quad (6)$$

where  $U_i$  is the overall heat transfer coefficient based on the inside surface area of a single flow passage. This coefficient is computed as

$$U_i = \left[ \frac{1}{h} + \frac{\delta}{k_m} \right]^{-1} \quad (7)$$

where  $\delta$  is a characteristic path length for conduction through the cold plate material from the interior wall of the flow passage to the cold plate external surface. Equations (1) through (6) can be written in the following dimensionless forms with the aid of reference values, denoted by the superscript \*, which are determined from a specific set of design conditions:

$$\frac{\dot{m}}{\dot{m}^*} = \frac{Q h_{fg}^*}{Q^* h_{fg}} \quad (8)$$

$$\frac{A_o}{A_o^*} = \frac{n}{n^*} \quad (9)$$

$$\frac{h}{h^*} = \frac{f(T) G}{f(T^*) G^*} \quad (10)$$

$$\frac{G}{G^*} = \frac{\dot{m}^*}{\dot{m} n} \quad (11)$$

$$\frac{q''}{q''^*} = \frac{Q A_o^*}{Q^* A_o} \quad (12)$$

$$\frac{q''}{q''^*} = \frac{U_i}{U_i^*} \quad (13)$$

In these equations, parameters without a superscript are those for the new set of operating conditions. Next, equations (8) through (13) can be combined to produce the following equation for the mass flux of the fluid through each flow passage

$$G = \frac{k_m}{\delta} \left[ \frac{G^* h_{fg}^*}{U_i^* h_{fg}} - \frac{f(T^*) G^*}{f(T) h^*} \right] \quad (14)$$

With the mass flux known, the overall heat transfer coefficient can be computed from

$$U_i = U_i^* \frac{G h_{fg}}{G^* h_{fg}^*}$$

This expression is obtained by combining Eqs.(8), (9) and (11) through (13). Next the surface heat flux can be determined from Eq. (13), and the

heat transfer surface area required for the new operating conditions can be computed from Eq. (5). Because the ratio of the plate surface area to the internal wetted perimeter is assumed constant, the ratio of the cold plate volume to the plate surface area is also assumed constant,

$$\frac{VOL}{A_0} = C_1 \quad (15)$$

Thus, the volume can be determined once the surface area is known. In addition, the weight of the cold plate is directly proportional to the cold plate volume and the density of the cold plate material

$$W = C_2 \rho_m VOL \quad (16)$$

The analysis presented here is incorporated in subroutine TPCP, and the reference values for this analysis are listed in Table 4.

#### CAPILLARY COLD PLATE MODEL (Subroutine CAPCP)

The capillary plate is assumed to have an equipment mounting face surface area of  $A_0$ , and the design is a grooved plate described in Reference (15). The power,  $Q$ , dissipated by the equipment mounted on the cold plate is assumed to be uniformly distributed over the surface of the cold plate. The cooling fluid enters the cold plate as a saturated liquid at temperature  $T_f$  and leaves at temperature  $T_f$  with a quality of  $X$ . The cold plate operating temperature is  $T_p$ , and the temperature difference  $(T_p - T_f)$  is assumed to be the same for all operating conditions. The total mass flow rate,  $\dot{m}$ , of fluid in the cold plate is computed from the

TABLE 4. Reference Design Values for Two-Phase Cold Plate Analysis.

<u>Variable</u>		<u>Value</u>	<u>Reference</u>
$Q^*$		5 kW	
$q''^*$	QPR	0.6 kW/ft <sup>2</sup>	2
$\dot{m}^*$	DOTMR	17.97 lb/hr	
$U_i^*$	UR	296.4 Btu/hr-ft <sup>2</sup> -°F (computed)	
$G^*$	GR	1.5 x 10 <sup>4</sup> lb/ft <sup>2</sup> -hr	
$T^*$	TR	20°C	2
$(T_p - T_f)^*$	DELTA	9°F	
$h^*$	HR	377 Btu/hr-ft <sup>2</sup> -°F	
$\delta$	DELTA	0.006 ft	
$C_1$	C1	0.0833 ft	
$C_2$	C2	0.22	
material*		stainless steel	
fluid*		water	
$\rho_m^*, k_m^*$		evaluated for material*	
$\rho^*, h_{fg}^*, \mu^*, k^*$		evaluated for fluid* at $T^*$	

following expression:

$$\dot{m} = \frac{Q}{X h_{fg}} \quad (1)$$

The quality at the exit is assumed to be the same for all operating conditions. The inside evaporative heat transfer coefficient is determined by [15]

$$h_{\text{evap}} = \frac{d_1 k_f}{d_2 - \left[ \frac{k_f}{k_m} \right] \ln \left[ d_3 \frac{k_f}{k_m} \right]} \quad (2)$$

where the constants  $d_1$ ,  $d_2$  and  $d_3$  are related to geometric characteristics of the cold plate.

The heat flux at the cold plate surface is computed from

$$q'' = \frac{Q}{A_0} \quad (3)$$

where  $A_0$  is the area of the mounting surface. The heat flux is also related to the difference between the plate surface temperature and the average fluid temperature by the expression

$$q'' = U(T_p - T_f) \quad (4)$$

where  $U$  is the overall heat transfer coefficient based on the outside surface area of the cold plate. This coefficient is computed as

$$U = \left[ \frac{1}{h_{\text{evap}}} + \frac{\delta}{k_m} \right]^{-1} \quad (7)$$

where  $\delta$  is the grooved-plate thickness from the cold plate mounting surface

to the base of the grooves.

The following set of computations is performed to determine the heat transfer surface area, volume, and weight for the capillary cold plate:

1. Calculate  $\dot{m}$  from known heat load, working fluid and operating temperature using Eq. (1). This information is subsequently used to size the supply and return lines.
2. Calculate  $h_{\text{evap}}$  from Eq. (2) using known plate material, working fluid, and operating temperature.
3. Calculate  $U$  from Eq. (5)
4. Calculate  $q''$  from Eq. (4)
5. Calculate the heat transfer area,  $A_o$ , from Eq. (3).
6. The volume is determined from

$$\frac{\text{VOL}}{A_o} = C_1 \quad (6)$$

where  $C_1$  is based upon the design from Reference (\*).

7. The cold-plate weight is then computed from

$$W = C_2 \rho_m \text{VOL} \quad (7)$$

where  $C_2$  is also based upon the design from Reference (\*).

The analysis presented here is incorporated in subroutine CAPCP, and design values from Reference (15) are listed in Table 5.

#### BUS HEAT EXCHANGER MODEL (Subroutine BUSHX)

The bus heat exchanger model is a linear model based upon average data from Reference (2). The heat transfer area for a 1-kW system is assumed to be 2.9 ft<sup>2</sup>, and the heat transfer area for other system sizes is scaled

Table 5. Design Values for Capillary Cold Plate Analysis  
 (from Reference [15] except as noted)

Variable	Value
$d_1$	1702 ft <sup>-1</sup>
$d_2$	0.076
$d_3$	0.0104
$C_1$	0.148 ft
$C_2$	0.424 estimated from Ref. (15)
fluid	Freon-11
$T_f$	25°C
material	aluminum
$x$	1.0
$A_0$	0.1614 ft <sup>2</sup>
$\delta$	0.0313 ft
$h_{fg}, k_f$	evaluated for F-11 at 25°C
$k_m, \rho_m$	evaluated for aluminum
$T_p - T_f$	9°F (5°C) assumed
$h_{evap}$	1245 Btu/hr-ft <sup>2</sup> -°F (Eq. (2))
$\dot{U}$	883 Btu/hr-ft <sup>2</sup> -°F (Eq. (5))
$q''$	2.33 kW/ft <sup>2</sup> (Eq. (4))
VOL	0.0239 ft <sup>3</sup> (Eq. (6))
$\dot{W}$	1.7 lbm (Eq. (3))
$\dot{m}$	7.47 lbm/hr (Eq. (1))

linearly with the heat load. The weight of the heat exchanger is computed on the basis of 1.08 lb/ft<sup>2</sup> of heat transfer area, the the volume is computed on the basis of 0.084 ft<sup>3</sup>/ft<sup>2</sup> of heat transfer area.

#### SIZING LIQUID SUPPLY AND RETURN LINES (subroutine LIQLINE)

The pipe sizes for liquid supply or liquid return lines are determined by minimizing the weight of the piping system [2]. Each segment of pipe in the longest pipe run is optimized individually by minimizing the mass or weight of the segment which is determined from

$$\text{Mass} = M_i = \text{mass of pipe} + \text{mass of liquid} + \text{pump power penalty mass}$$

where

$$\text{mass of pipe} = \rho_{SS} L_i \pi (D_i + t_i) t_i$$

$$\text{mass of liquid} = \rho_L \pi D_i^2 L_i / 4$$

$$\text{pump power penalty mass} = M_p P_p$$

The pump power penalty is  $M_p$  (lb/kW) and the pump power is determined from

$$P_p = \frac{\dot{m}_i \Delta P_i}{\rho_L \eta_p}$$

The pressure drop for the segment of pipe is calculated from

$$\Delta P_i = \frac{8 L_i \dot{m}_i^2 f_i}{\pi^2 \rho_L D_i^5}$$

where the friction factor for turbulent flow in smooth pipes [8] is

$$f_i = 0.316/Re^{1/4}$$

and for laminar flow [10] is

$$f_i = 64/Re$$

The Reynolds number is defined as

$$Re = \frac{4 \dot{m}_i}{\pi \mu_L D_i}$$

Thus the pipe segment mass to be minimized is

$$M_i = \rho_{SS} L_i \pi (D_i + t_i) t_i + \rho_L \pi D_i^2 L_i / 4 + M_p \frac{\dot{m}_i \Delta P_i}{\rho_L \eta_p}$$

The pipe thickness,  $t_i$ , is determined by the internal pipe diameter according to standard pipe and tube specifications.

#### SIZING VAPOR LINES (Subroutine VAPLINE)

The vapor line sizes in two-phase systems are selected consistent with the desire to limit the loss of stagnation pressure and stagnation temperature in vapor return lines [1]. The analysis of these losses is based upon adiabatic, compressible pipe flow with friction [11] as outlined below.

The vapor line diameter for each pipe segment in the vapor return line is chosen such that the stagnation pressure drop is less than 2 percent of the stagnation pressure at the exit of the cold plate. The conditions at the inlet of the vapor line are denoted by the subscript 1 and the subscript 2 denotes the conditions at the exit, and we require that

$$P_{02}/P_{01} \geq 0.98 \quad (6)$$

where the zero subscript designates stagnation conditions.

The stagnation pressure ratio can be computed from

$$\frac{P_{02}}{P_{01}} = \frac{M_1}{M_2} \left[ \frac{\left(1 + \frac{k-1}{2} M_2^2\right)}{\left(1 + \frac{k-1}{2} M_1^2\right)} \right]^{\frac{(k+1)}{2(k-1)}}$$

where

$M_i = V_i/C_i$  is the Mach number

$C_i = \sqrt{kRT_i/g_c}$  is the sonic velocity

$k = c_p/c_v$  is the ratio of specific heats for the vapor

$R$  is the gas constant for the vapor

The general procedure for determining the information necessary to calculate the stagnation pressure ratio is iterative in nature as outline in the following.

1. Assume a pipe diameter  $D$  and calculate the inlet vapor velocity,  $V_1$ , from the known mass flow rate.
2. Calculate the inlet Mach number,  $M_1$
3. Calculate the inlet Reynolds number,  $Re_1$ , determine the friction factor,  $f$ , for turbulent or laminar flow as dictated by the Reynolds number, and calculate  $(fL/D)_{\text{actual}}$  from the given pipe length and assumed diameter.
4. Calculate the inlet stagnation temperature

$$T_{01} = T_1 + \frac{V_1^2}{2C_p}$$

and the inlet stagnation pressure

$$P_{01} = P_1 \left( \frac{T_{01}}{T_1} \right)^{k/(k-1)}$$

5. Calculate the quantity  $\bar{f}L^*/D)_1$  at the inlet,

$$\left. \frac{\bar{f}L^*}{D} \right)_1 = \frac{1 - M_1^2}{k M_1^2} + \frac{k+1}{2k} \ln \left[ \frac{(k+1)M_1^2}{2[1 + \frac{1}{2}(k-1)M_1^2]} \right]$$

and the quantity  $\left. \frac{\bar{f}L^*}{D} \right)_2$  from

$$\left. \frac{\bar{f}L^*}{D} \right)_2 = \left. \frac{\bar{f}L^*}{D} \right)_1 - \left. \frac{\bar{f}L}{D} \right)_{\text{actual}}$$

6. Solve the following transcendental equation for the exit Mach number,  $M_2$ :

$$\left. \frac{\bar{f}L^*}{D} \right)_2 = \frac{1 - M_2^2}{k M_2^2} + \frac{k+1}{2k} \ln \left[ \frac{(k+1)M_2^2}{2[1 + \frac{1}{2}(k-1)M_2^2]} \right]$$

7. Finally, compute  $P_{02}/P_{01}$  from Equation (6). If  $P_{02}/P_{01} < 0.98$ , choose a large pipe diameter and repeat steps 1 through 6. If  $P_{02}/P_{01} > 0.98$  choose a smaller pipe diameter and repeat steps 1 through 6. If  $P_{02}/P_{01} \approx 0.98$ , the assumed pipe diameter is adequate for this pipe segment.

## SUMMARY

The orbiting space station being developed by the National Aeronautics and Space Administration will have many thermal sources and sinks as well as requirements for the transport of thermal energy through large distances. The station is also expected to evolve over twenty or more years from an initial design. As the station evolves, thermal management will become more difficult. Thus, analysis techniques to evaluate the effects of changing various thermal loads and the methods utilized to control temperature distributions in the station are essential.

Analysis techniques including a user-friendly computer program, have been developed which should prove quite useful to thermal designers and systems analysts working on the space station. The program uses a data base and user input to compute costs, sizes and power requirements for individual components and complete systems. User input consists of selecting mission parameters, selecting thermal acquisition configurations, transport systems and distances, and thermal rejection configurations. The capabilities of the program may be expanded by including additional thermal models as subroutines.

## REFERENCES

1. Kreith, F. and Black, W. Z., Basic Heat Transfer, Harper & Row, New York, 1980.
2. "High Efficiency Automated Thermal Control System Study: Systems Preliminary Design Performance Analysis and Specifications - Cabin Thermal Bus," Shuttle Integration and Satellite Systems Division, Rockwell International Corporation, SSD84-0075 (May 1984).
3. "Thermal Bus Subsystem for Large Space Platforms" Concept Trade Study, Grumman Aerospace Corp., Nov., 1983.
4. "Thermal Bus Subsystem for Large Space Platforms" Preliminary Design Review, Grumman Aerospace Corp., Nov., 1983.
5. Chang, W. S., "Heat Pipe Startup from the Supercritical State," Ph.D. Thesis, Georgia Institute of Technology, March 1981.
6. Colwell, Gene T., "Prediction of Cryogenic Heat Pipe Performance," Annual Report for 1975 on NASA Grant NSG-2054, by Georgia Tech to NASA Ames and NASA Goddard, February 1, 1976.
7. "Space Station Reference Configuration Description," NASA JSC, August 1984.
8. Sadunas, J., and A. Lehtinen, "H.E.A.T. Contract Preliminary Design Review," Rockwell International to NASA JCS, August 16, 1984.
9. Sadunas, J., and A. Lehtinen, "H.E.A.T. Contract Critical Design Review Data Package", NAS9-16782, Rockwell International for NASA JSC, December 7, 1984.
10. Olson, R. M., Essentials of Engineering Fluid Mechanics, Fourth Ed., Harper & Row, New York, 1980.
11. Shapiro, A. H., The Dynamics and Thermodynamics of Compressible fluid Flow, Vol. 1, The Ronald Press Co., New York, 1958.
12. White, K. Alan, III, "Liquid Droplet Radiator Development Status," NASA Technical Memorandum 89852, July, 1987.
13. Presler, Alden F., Coles, Carolyn E., Diem-Kirsop, Priscilla S., and White, K. Alan, III, "Liquid Droplet Radiator Program at the NASA Lewis Research Center," ASME Paper 86-HT-15, June, 1986.
14. Chubb, Donald L. and White, K. Alan, III, "Liquid Sheet Radiator," NASA Technical Memorandum 89841, July, 1987.
15. "Thermal Bus Subsystem for L.S.P.," Concept Trade Study, Grumman Aerospace Corporation, May, 1983.

APPENDICES

APPENDIX A  
DATA BASE CONTENTS

<u>Record No.</u>	<u>Format</u>	<u>Variable Names</u>
1	(215,11A10)	NOSYS, NOREC, (NAMES(I), I=1,11)
2-6	(12A10)	(NAMES(I), I=12*J, 12*J+11) J ranges from 1 to 5 as record number changes
7	(15F8.3)	(RMISION(I), I=1,15)
8-22	(12F10.6)	(CANDAT(IMOD, I), I=1,12) IMOD ranges from 1 to 15 as record number changes

System configuration file 1 ;(i.e. NAMES(1) - default configuration

23	(A10,A6,A34,A70)	NAME, DATE, PREPARE, TITLE
24-30	(20F6.2)	(MODDATA(N, J), J=1,20) N ranges from 1 to 7 as record number changes
31	(15F8.2)	(MODDATA(8, J), J=1,15)
32-38	(7A4,14F6.2,4A2)	(SYSNAM(N, J), J=1,7), (SYSDATA(N, J), J=1,8), (SYSDATA(N, J), J=1,15), PMATL(N), PMATL(N+7), PMATL(15), PMATL(16) N ranges from 1 to 7 as record number changes
39	(7A9,A53)	(MODULE(J), J=1,7), DUMNAME

System configuration file 2 (i.e. NAMES(2)) - configuration

17 records for each configuration, arranged as described above for the default configuration. Each subsequent block of 17 records contains a separate system configuration file.

## VARIABLE DEFINITIONS

NOSYS                    number of system configuration files in the data base

NOREC                    number of records required for each system configuration file

NAMES(I)                 name of system configuration file I

RMISION(I)              mission model parameter file  
I=1                      not used  
I=2                      mission duration, days  
I=3                      resupply interval, days  
I=4                      power penalty, lb/kW  
I=5                      control penalty, lb/kW  
I=6                      propulsion penalty, lb/kW  
I=7-10                  not used  
I=11                     probability of meteoroid penetration  
I=12                     transportation cost factor, k\$/lb  
I=13                     maintenance cost factor, k\$/lb  
I=14                     integration cost factor, %  
I=15                     programmatic cost factor, %

CANDDAT(IMOD,I)         candidate data file for candidate having index IMOD  
(IMOD=1-5 for five acquisition candidates, IMOD=6-10  
for five transport candidates, IMOD=11-15 for five  
rejection candidates)

I=1                      weight of spares for 90 days, lb  
I=2                      volume of spares for 90 days, ft<sup>3</sup>  
I=3                      weight of consumables for 90 days, lb  
I=4                      volume of consumables for 90 days, ft<sup>3</sup>  
I=5                      reliability (0-8)  
I=6                      technology readiness (0-8)  
I=7                      pacing technology problems (0-8)  
I=8                      90 day maintenance time, hr  
I=9                      nonrecurring design, development, test and certify,  
1983 million \$  
I=10                     spares and consumables to operate for 90 days, 1983  
million \$  
I=11                     cost of flight unit, 1983 million \$  
I=12                     candidate rating, kW

MODDATA(IMOD,I)        cold plate location data for module IMOD (<8)

I=1-5                    supply line lengths (ft) for CP 1-5  
I=6-10                  branch supply lengths (ft) for CP 1-5  
I=11-15                return line lengths (ft) for CP 1-5  
I=16-20                branch return lengths (ft) for CP 1-5

MODDAT(8,I)            transport lengths to modules  
     I=1,3,4,7,9,11,13    length (ft) from main radiator to modules 1-7  
     I=2,3,6,8,10,12,14    branch length (ft) to modules 1-7

SYSNAME(IMOD,I)  
     I=1            either "AUTO" for autonomous or "INTG" for  
                   integrated  
     I=2            either "CCP" or "TPCP" or "CPCP" - cold plate  
                   candidate abbreviations  
     I=3            either "PLL" or "PTPL" or "HHPR" - transport  
                   candidate abbreviations  
     I=4            either "HPR" or "HHPR" or "LDR" - rejection candidate  
                   abbreviations  
     I=5            either "WATE" or "AMMO" or "F-11" - equipment loop  
                   working fluid abbreviations  
     I=6            either "WATE" or "AMMO" or "F-11" - transport loop  
                   working fluid abbreviations  
     I=7            either "WATE" or "AMMO" or "F-11" or "ACET" or  
                   "METH" - rejection system working fluid  
                   abbreviations

SYSDATA(IMOD,I)        system configuration data for module IMOD  
     I=1            number of active cold plates (<6)  
     I=2            cold plate operating temperature, C  
     I=3            metabolic load, kW  
     I=4-8          loads, kW, for cold plates 1-5  
     I=9-11        not used  
     I=12          radiator surface temperature, C  
     I=13          emissivity of radiator surface  
     I=14          absorptivity of radiator surface  
     I=15          heat pipe radiator operating temperature, C

PMATL(I)            material types - either "AL" or "SS"  
     I=1-7          material type for cold plates and pipe in modules 1-  
                   7  
     I=8-15        material type for radiators of modules 1-7  
     I=16          material type for transport loop

MODULE(I)            names for modules 1-7 (max 9 characters)

APPENDIX B  
ASSESSMENT ALGORITHMS

Acquisition Assessment Algorithms for Individual Modules

- A. Reliability, Technology Readiness and Pacing Technology Rating:  
integrated modules

$$\begin{Bmatrix} R_i \\ TR_i \\ PT_i \end{Bmatrix} = \begin{Bmatrix} R_{c,a} \\ TR_{c,a} \\ PT_{c,a} \end{Bmatrix}$$

For autonomous modules

$$\begin{Bmatrix} R_i \\ TR_i \\ PT_i \end{Bmatrix} = \begin{Bmatrix} \text{Minimum } (R_{c,a}, R_{c,t}, R_{c,r}) \\ \text{Minimum } (TR_{c,s}, TR_{c,t}, TR_{c,r}) \\ \text{Minimum } (RT_{c,a}, PT_{c,t}, PT_{c,r}) \end{Bmatrix}$$

- B. Metabolic Load

$ML_i = ML_i$  from system configuration file,  $i = 1, \dots, n$

- C. Acquisition Load

$$AL_i = \sum_{j=1}^p (CP_j)_i ; \quad i = 1, \dots, n$$

$ML_T = \text{sum of } AL_i \text{ for integrated modules}$

$$ML_R = ML_T$$

D. Resupply consumables

$$RC_i = RC_m + (WS_a + WC_a) * \left[ \frac{AL_i}{CR_a} \right] \left[ \frac{RI}{90} \right] \text{ for integrated modules}$$

$$RC_i = RC_m + \left[ \sum_{k=e,t,r} (WS_k + WC_k) / CR_k \right] (AL_i) \left[ \frac{RI}{90} \right] \text{ for autonomous modules}$$

$$RC_k = (WS_k + WC_k) \left[ \frac{ML_k}{CR_k} \right] \left[ \frac{RI}{90} \right] ; k = T, R$$

E. Resupply Volume

$$RV_i = RV_m + (VS_a + VC_a) \left[ \frac{AL_i}{CR_a} \right] \left[ \frac{RI}{90} \right] \text{ for integrated modules}$$

$$RV_i = RV_m + \left[ \sum_{k=a,t,r} (VS_k + VC_k) / CR_k \right] (AL_i) \left[ \frac{RI}{90} \right] \text{ for autonomous modules}$$

$$RV_k = (VS_k + VC_k) \left[ \frac{ML_k}{CR_k} \right] \left[ \frac{RI}{90} \right]$$

F. Power Required

$PR_i = \text{external power requirement of TCS for module (or main transport/main rejection system) computed in candidate subroutine; } i = 1, \dots, n \text{ and } T, R \text{ (Note 1)}$

G. Power System Impact

$$PSI_i = (PR_i)(PSP); \quad i = 1, \dots, n \text{ and } T, R$$

H. Control System Impact

$$CSI_i = (PR_i)(CSP); \quad i = 1, \dots, n \text{ and } T, R$$

I. Propulsion System Impact

$$PRSI_i = (PR_i)(PRSP); \quad i = 1, \dots, n \text{ and } T, R$$

J. Launch Weight

$LW_i$  = launch weight of TCS for module (or main transport/rejection system) computed in candidate subroutine;  $i = 1, \dots, n$  and  $T, R$  (Note 1)

K. Launch Volume

$LV_i$  = launch volume of TCS for module (or main transport, rejection system) computed in candidate subroutine;  $i = 1, \dots, n$  and  $T, R$  (Note 1)

L. Equivalent Launch Weight

$$ELW_i = RC_i + PSI_i + CSI_i + PRSI_i + LW_i; \quad i = 1, \dots, n \text{ and } T, R$$

M. Maintenance Time Over Resupply Interval

$$MT_i = MT_m + (RMT_a) \left[ \frac{AL_i}{CR_a} \right] \left[ \frac{RI}{90} \right] \text{ for integrated modules}$$

$$MT_i = MT_m + \left[ \sum_{k=a,t,r} (RMT_k)/CR_k \right] (AL_i) \left[ \frac{RI}{90} \right] \text{ for autonomous modules}$$

$$MT_k = (RMT_k) \left[ \frac{MT_k}{CR_k} \right] \left[ \frac{RI}{90} \right]; \quad k = T, R$$

N. Acquisition Surface Area

ASA<sub>i</sub> = total cold plate surface area for modules computed in candidate subroutine; i = 1, ..., n.

O. Rejection Surface Area

RSA<sub>i</sub> = RSA<sub>m</sub> + rejection surface area for autonomous module (or main rejection system) computed in candidate subroutine;  
i = autonomous modules and R.

Note: The following costs are FY83 million dollars.

P. Cost of Design, Development, Test and Evaluate

$$CDTE_i = (DDTE_a) / (\text{number of modules having same acquisition candidate});$$

i = 1, ..., n

$$CDTE_k = (DDTE_k) / (\text{number of modules having same k candidate} + 1); \quad k=T, R$$

Q. Cost of Flight Unit, Spares and Consumables for Initial Launch

$$CFU_i = \left[ FU_a + (CSC_a) \left[ \frac{RI}{90} \right] \right] \left[ \frac{AL_i}{CR_a} \right]; \quad i = 1, \dots, n \text{ (Note 1)}$$

$$CRU_k = \left[ FU_k + (CSC_k) \left[ \frac{RI}{90} \right] \right] \left[ \frac{ML_k}{CR_k} \right]; \quad k = T, R$$

1\*

R. Cost of spares and consumables to operate over mission

$$CSC_i = (CS_a) \left[ \frac{MD}{RI} - 1 \right] \left[ \frac{AL_i}{CR_a} \right]; \quad i = 1, \dots, n \text{ (Note 1)}$$

$$CSC_k = (CS_k) \left[ \frac{MD}{RI} - 1 \right] \left[ \frac{ML_k}{CR_k} \right]; \quad k = T, R$$

S. Integration Cost

$$CI_i = (CDTE_i + CFU_i) (ICF/100); \quad i = 1, \dots, n \text{ and } T, R$$

T. Programmatic Cost

$$CPR_i = (CDTE_i + CFU_i) (PCF/100); \quad i = 1, \dots, n \text{ and } T, R$$

U. Transportation Costs for a Spares and Consumables Over Mission

$$CTSC_i = (RC_i) \left[ \frac{MP}{RI} - 1 \right] (TCF/1000); \quad i = 1, \dots, n \text{ and } T, R$$

V. Transportation cost for flight unit, spares and consumables to operate over initial resupply interval

$$CTFU_i = (RC_i + LW_i) (TCF/1000); \quad i = 1, \dots, n \text{ and } T, R$$

---

1\*

Note 1: Includes only acquisition system for integrated modules; includes acquisition, transport and reject systems for autonomous modules.

W. Cost of Maintenance for Mission

$$CMM_i = (MT_i) \left[ \frac{MD}{RI} - 1 \right] \left[ \frac{MCF}{1000} \right] ; i = 1, \dots, n \text{ and } T, R$$

X. Life Cycle Cost for Mission

$$CLC_i = (CDTE_i + CFU_i + CCS_i + CI_i + CPR_i + CTSC_i + CTFU_i + CMM_i) ;$$

$$i = 1, \dots, n \text{ and } T, R$$

## II. Summary Assessment Algorithms

$$A. \quad \begin{Bmatrix} R_A \\ TR_A \\ PT_A \end{Bmatrix} = \begin{Bmatrix} \text{Minimum } (R_i; i = 1, \dots, n) \\ \text{Minimum } (TR_i; i = 1, \dots, n) \\ \text{Minimum } (PT_i; i = 1, \dots, n) \end{Bmatrix}$$

$$\begin{Bmatrix} R_O \\ TR_O \\ PT_O \end{Bmatrix} = \begin{Bmatrix} \text{Minimum } (R_k; k = A, T, R) \\ \text{Minimum } (TR_k; k = A, T, R) \\ \text{Minimum } (PT_k; k = A, T, R) \end{Bmatrix}$$

$$B. \quad ML_A = \sum_{i=1}^n ML_i ; ML_O = ML_A$$

C. AAL = Sum of  $AL_i$  for autonomous modules  
IAL = Sum of  $AL_i$  for integrated modules

D. through X.

$$\text{Value}_A = \sum_{i=1}^n \text{Value}_i$$

$$\text{Value}_O = \text{Value}_A + \text{Value}_T + \text{Value}_R$$

## NOMENCLATURE FOR APPENDIX B

AAL	autonomous acquisition load, kW
ACDF	acquisition candidate data file
AL	acquisition load, kW
ASA	acquisition surface area, ft <sup>2</sup>
CDTE	cost of design, development, test and evaluation, million \$
CFU	cost of flight unit, spares, and consumables for initial launch, million \$
CI	integration cost, million \$
CLC	life cycle cost for mission, million \$
CP	cold plate load, kW
CR	candidate rating, kW, from ACDF
CS	cost of spares and consumables for 90 days from ACDF, million \$
CSC	cost of spares and consumables to operate over mission, million \$
CSI	control system impact, lb
CSP	control system penalty, lb/kW, from MMPF
CTFU	transportation cost for flight unit, spares and consumables to operate over initial resupply interval, million \$
CTSC	transportation cost for spares and consumables over mission, million \$
DDTE	design, development, test and evaluate cost from ACDF, million \$
FU	flight unit cost for initial launch cost from ACDF, million \$
IAL	integrated acquisition load, kW
ICF	integration cost factor, %, from MMPF
LV	launch volume, ft <sup>3</sup>
LW	launch weight, lb

MCF maintenance cost factor, k\$/hr, from MMPF  
MD mission duration, days, from MMPF  
ML metabolic load, kW  
MMPF mission model parameter file  
MT maintenance time over resupply interval, hr  
PCF programmatic cost factor, %, from MMPF  
PR power required, kW  
PRSI propulsion system impact, lb  
PRSP propulsion system penalty, lb/kW, from MMPF  
PSI power system impact, lb  
PSP power system penalty, lb/kW, from MMPF  
PT pacing technology rating  
R reliability  
RC resupply consumables, lb  
RI resupply interval, days, from MMPF  
RMT 90-day maintenance time, hr, form ACDF  
RSA rejection surface area, ft<sup>2</sup>  
RV resupply volume, ft<sup>3</sup>  
TCF transportation cost factor, k\$/lb from MMPF  
TR technology readiness  
VC volume of consumables from 90 days, ft<sup>3</sup>, ACDF  
VS volume of spares for 90 days, ft<sup>3</sup>, ACDF  
WC weight of consumables for 90 days, lb, from ACDF  
WX weight of spares for 90 days, lb, from ACDF

## Subscripts

a	acquisition candidate
A	total acquisition system
c	candidate data file value
i	module i
j	cold plate
m	metabolic loop
n	number of modules
o	overall assessment
p	number of cold plates
r	rejection candidate
R	main rejection system
t	transport candidate
T	main transport system

**APPENDIX C**  
**DEFAULT DATA BASE**

**A. Mission Model Parameters.**

MISSION MODEL PARAMETERS

1.	M...MISSION DURATION, DAYS:	3650.00
2.	R...RESUPPLY INTERVAL, DAYS:	90.00
3.	NP..POWER PENALTY, LB/KW:	350.00
4.	NC..CONTROL PENALTY, LB/KW:	.00
5.	NP1.PROPULSION PENALTY, LB/KW:	60.00
6.	P...PROBABILITY OF METEOROID PENETRATION, (0.920 TO 0.993):	.990
7.	CFA.TRANSPORTATION COST FACTOR, THOUSAND DOLLARS/LB:	1.60
8.	MR..MAINTENANCE COST FACTOR, THOUSAND DOLLARS/HR:	35.00
9.	IF..INTEGRATION COST FACTOR, %:	35.00
10.	PF..PROGRAMMATIC COST FACTOR, %:	70.00

**B. Candidate data files**

i. Candidate Name: CONDUCTIVE COLD PLATE

1.	CANDIDATE RATING, KW:	50.000
2.	WEIGHT OF SPARES FOR 90 DAYS, LB:	22.100
3.	VOLUME OF SPARES FOR 90 DAYS, FT3:	6.350
4.	WEIGHT OF CONSUMABLES FOR 90 DAYS, LB:	.000
5.	VOLUME OF CONSUMABLES FOR 90 DAYS, FT3:	.000
6.	RELIABILITY (0-8):	8.000
7.	TECHNOLOGY READINESS (0-8):	8.000
8.	PACING TECHNOLOGY PROBLEMS (0-8):	8.000
9.	90 DAY MAINTENANCE TIME, HR:	5.000
10.	NONRECURRING DESIGN, DEVELOPMENT, TEST AND CERTIFY, 1987 MILLION DOLLARS:	.600
11.	SPARES AND CONSUMABLES TO OPERATE FOR 90 DAYS, 1987 MILLION DOLLARS:	.040
12.	COST OF FLIGHT UNIT, 1987 MILLION DOLLARS:	.900

ii. Candidate Name: TWO-PHASE COLD PLATE

1.	CANDIDATE RATING, KW:	50.000
2.	WEIGHT OF SPARES FOR 90 DAYS, LB:	2.900
3.	VOLUME OF SPARES FOR 90 DAYS, FT3:	.850
4.	WEIGHT OF CONSUMABLES FOR 90 DAYS, LB:	.000
5.	VOLUME OF CONSUMABLES FOR 90 DAYS, FT3:	.000
6.	RELIABILITY (0-8):	6.000
7.	TECHNOLOGY READINESS (0-8):	6.000

8.	PACING TECHNOLOGY PROBLEMS (0-8):	6.000
9.	90 DAY MAINTENANCE TIME, HR:	4.000
10.	NONRECURRING DESIGN, DEVELOPMENT, TEST AND CERTIFY, 1987 MILLION DOLLARS:	.850
11.	SPARES AND CONSUMABLES TO OPERATE FOR 90 DAYS, 1987 MILLION DOLLARS:	.060
12.	COST OF FLIGHT UNIT, 1987 MILLION DOLLARS:	.970
iii. Candidate Name: CAPILLARY COLD PLATE		
1.	CANDIDATE RATING, KW:	50.000
2.	WEIGHT OF SPARES FOR 90 DAYS, LB:	3.000
3.	VOLUME OF SPARES FOR 90 DAYS, FT3:	.900
4.	WEIGHT OF CONSUMABLES FOR 90 DAYS, LB:	.000
5.	VOLUME OF CONSUMABLES FOR 90 DAYS, FT3:	.000
6.	RELIABILITY (0-8):	6.000
7.	TECHNOLOGY READINESS (0-8):	6.000
8.	PACING TECHNOLOGY PROBLEMS (0-8):	6.000
9.	90 DAY MAINTENANCE TIME, HR:	4.000
10.	NONRECURRING DESIGN, DEVELOPMENT, TEST AND CERTIFY, 1987 MILLION DOLLARS:	.750
11.	SPARES AND CONSUMABLES TO OPERATE FOR 90 DAYS, 1987 MILLION DOLLARS:	.050
12.	COST OF FLIGHT UNIT, 1987 MILLION DOLLARS:	.950
iv. Candidate Name: PUMPED LIQUID LOOP		
1.	CANDIDATE RATING, KW:	50.000
2.	WEIGHT OF SPARES FOR 90 DAYS, LB:	157.800
3.	VOLUME OF SPARES FOR 90 DAYS, FT3:	.180
4.	WEIGHT OF CONSUMABLES FOR 90 DAYS, LB:	.000
5.	VOLUME OF CONSUMABLES FOR 90 DAYS, FT3:	.000
6.	RELIABILITY (0-8):	8.000
7.	TECHNOLOGY READINESS (0-8):	8.000
8.	PACING TECHNOLOGY PROBLEMS (0-8):	8.000
9.	90 DAY MAINTENANCE TIME, HR:	5.000
10.	NONRECURRING DESIGN, DEVELOPMENT, TEST AND CERTIFY, 1987 MILLION DOLLARS:	.600
11.	SPARES AND CONSUMABLES TO OPERATE FOR 90 DAYS, 1987 MILLION DOLLARS:	.040
12.	COST OF FLIGHT UNIT, 1987 MILLION DOLLARS:	.500
v. Candidate Name: PUMPED TWO-PHASE LOOP		
1.	CANDIDATE RATING, KW:	50.000
2.	WEIGHT OF SPARES FOR 90 DAYS, LB:	112.500
3.	VOLUME OF SPARES FOR 90 DAYS, FT3:	.720
4.	WEIGHT OF CONSUMABLES FOR 90 DAYS, LB:	.000
5.	VOLUME OF CONSUMABLES FOR 90 DAYS, FT3:	.000
6.	RELIABILITY (0-8):	6.000

7.	TECHNOLOGY READINESS (0-8):	6.000
8.	PACING TECHNOLOGY PROBLEMS (0-8):	6.000
9.	90 DAY MAINTENANCE TIME, HR:	4.000
10.	NONRECURRING DESIGN, DEVELOPMENT, TEST AND CERTIFY, 1987 MILLION DOLLARS:	.800
11.	SPARES AND CONSUMABLES TO OPERATE FOR 90 DAYS, 1987 MILLION DOLLARS:	.070
12.	COST OF FLIGHT UNIT, 1987 MILLION DOLLARS:	.900
vi. Candidate Name: HIGH CAPACITY HEAT PIPE		
1.	CANDIDATE RATING, KW:	50.000
2.	WEIGHT OF SPARES FOR 90 DAYS, LB:	115.000
3.	VOLUME OF SPARES FOR 90 DAYS, FT3:	.750
4.	WEIGHT OF CONSUMABLES FOR 90 DAYS, LB:	.000
5.	VOLUME OF CONSUMABLES FOR 90 DAYS, FT3:	.000
6.	RELIABILITY (0-8):	6.000
7.	TECHNOLOGY READINESS (0-8):	6.000
8.	PACING TECHNOLOGY PROBLEMS (0-8):	6.000
9.	90 DAY MAINTENANCE TIME, HR:	4.000
10.	NONRECURRING DESIGN, DEVELOPMENT, TEST AND CERTIFY, 1987 MILLION DOLLARS:	.750
11.	SPARES AND CONSUMABLES TO OPERATE FOR 90 DAYS, 1987 MILLION DOLLARS:	.050
12.	COST OF FLIGHT UNIT, 1987 MILLION DOLLARS:	.700
vii. Candidate Name: GENERIC HEAT PIPE RADIATOR		
1.	CANDIDATE RATING, KW:	50.000
2.	WEIGHT OF SPARES FOR 90 DAYS, LB:	149.900
3.	VOLUME OF SPARES FOR 90 DAYS, FT3:	440.000
4.	WEIGHT OF CONSUMABLES FOR 90 DAYS, LB:	.000
5.	VOLUME OF CONSUMABLES FOR 90 DAYS, FT3:	.000
6.	RELIABILITY (0-8):	8.000
7.	TECHNOLOGY READINESS (0-8):	8.000
8.	PACING TECHNOLOGY PROBLEMS (0-8):	8.000
9.	90 DAY MAINTENANCE TIME, HR:	5.000
10.	NONRECURRING DESIGN, DEVELOPMENT, TEST AND CERTIFY, 1987 MILLION DOLLARS:	1.000
11.	SPARES AND CONSUMABLES TO OPERATE FOR 90 DAYS, 1987 MILLION DOLLARS:	.050
12.	COST OF FLIGHT UNIT, 1987 MILLION DOLLARS:	1.000
viii. Candidate Name: HIGH CAPACITY HEAT PIPE RADIATOR		
1.	CANDIDATE RATING, KW:	50.000
2.	WEIGHT OF SPARES FOR 90 DAYS, LB:	57.800
3.	VOLUME OF SPARES FOR 90 DAYS, FT3:	370.000
4.	WEIGHT OF CONSUMABLES FOR 90 DAYS, LB:	.000
5.	VOLUME OF CONSUMABLES FOR 90 DAYS, FT3:	.000

- 6. RELIABILITY (0-8): 6.000
- 7. TECHNOLOGY READINESS (0-8): 6.000
- 8. PACING TECHNOLOGY PROBLEMS (0-8): 6.000
- 9. 90 DAY MAINTENANCE TIME, HR: 4.000
- 10. NONRECURRING DESIGN, DEVELOPMENT, TEST AND CERTIFY, 1987 MILLION DOLLARS: 1.500
- 11. SPARES AND CONSUMABLES TO OPERATE FOR 90 DAYS, 1987 MILLION DOLLARS: .070
- 12. COST OF FLIGHT UNIT, 1987 MILLION DOLLARS: 1.600

ix. Candidate Name: LIQUID DROPLET RADIATOR

- 1. CANDIDATE RATING, KW: 50.000
- 2. WEIGHT OF SPARES FOR 90 DAYS, LB: 57.800
- 3. VOLUME OF SPARES FOR 90 DAYS, FT3: 370.000
- 4. WEIGHT OF CONSUMABLES FOR 90 DAYS, LB: .000
- 5. VOLUME OF CONSUMABLES FOR 90 DAYS, FT3: .000
- 6. RELIABILITY (0-8): 4.000
- 7. TECHNOLOGY READINESS (0-8): 4.000
- 8. PACING TECHNOLOGY PROBLEMS (0-8): 6.000
- 9. 90 DAY MAINTENANCE TIME, HR: 6.000
- 10. NONRECURRING DESIGN, DEVELOPMENT, TEST AND CERTIFY, 1987 MILLION DOLLARS: 6.000
- 11. SPARES AND CONSUMABLES TO OPERATE FOR 90 DAYS, 1987 MILLION DOLLARS: .100
- 12. COST OF FLIGHT UNIT, 1987 MILLION DOLLARS: 2.000

C. System Configurations

i. All module configuration are identical to the following:

LOGISTICS MODULE

ACQUISITION SUBSYSTEM: CONDUCTIVE COLD PLATE

TOTAL COLD PLATE CAPACITY, KW: 20.00

- 1. NUMBER OF COLD PLATES: 5.00
- 2. COLD PLATE OPERATING TEMPERATURE, C: 20.00
- 3. METABOLIC LOAD, KW: 2.36

	CP #1	CP #2	CP #3	CP #4	CP #5
4. HEAT REJECTION LOADS, KW:	4.00	4.00	4.00	4.00	4.00
5. MAIN SUPPLY LINE LENGTHS, FT:	8.00	4.00	4.00	4.00	4.00
6. BRANCH SUPPLY LINE LENGTHS, FT:	10.00	10.00	10.00	10.00	10.00
7. MAIN RETURN LINE LENGTHS, FT:	8.00	4.00	4.00	4.00	4.00
8. BRANCH RETURN LINE LENGTHS, FT:	10.00	10.00	10.00	10.00	10.00

- 9. WORKING FLUID: AMMONIA
- 10. PIPE MATERIAL: STAINLESS STEEL

ii. Main Transport System

- |                           |                    |
|---------------------------|--------------------|
| 1. MAIN TRANSPORT SYSTEM: | PUMPED LIQUID LOOP |
| 2. WORKING FLUID:         | AMMONIA            |
| 3. PIPE MATERIAL:         | STAINLESS STEEL    |

TRANSPORT LENGTHS FOR INTEGRATED MODULES

	LOGS	HAB2	LAB1	LAB2	EXPS	RESE
4. TO RADIATOR, FT:	50.00	90.00	75.00	100.00	65.00	80.00
5. BRANCH, FT:	.00	.00	.00	.00	.00	.00

iii. Main Rejection System

- |                                     |                            |
|-------------------------------------|----------------------------|
| 1. MAIN REJECTION SYSTEM:           | GENERIC HEAT PIPE RADIATOR |
| 2. RADIATOR SURFACE TEMPERATURE, C: | 24.20                      |
| 3. EMISSIVITY:                      | .78                        |
| 4. ABSORPTIVITY:                    | .30                        |
| 5. FLUID OPERATING TEMPERATURE, C:  | 37.00                      |
| 6. WORKING FLUID:                   | AMMONIA                    |
| 7. MATERIAL:                        | ALUMINUM                   |

**APPENDIX D  
SAMPLE OUTPUT FROM TCS PROGRAM**

The following analysis results are based upon data from the default data base except that the Habitat 1 Module is autonomous.

**CONTENTS**

Acquisition Assessment Results for Each Module except Habitat 1 (Logistics Module Illustrated).....	D-2
Acquisition Assessment Results for Habitat 1 Module.....	D-3
Summary Acquisition Assessment Results.....	D-4
Summary Transport Assessment Results.....	D-5
Summary Rejection Assessment Results.....	D-6
Overall Summary Assessment Results.....	D-7

(Additional output from the TCS program is automatically generated and stored in a local file named TAPE9. That file will contain information about the size, weight, volume and power required for the various components in each of the modules as well as in the transport and rejection systems. Samples of that output are not included in this report.)

SYSTEM CONFIGURATION: \*DEFAULTS\*

ACQUISITION ASSESSMENT RESULTS

LOGISTICS MODULE - INTEGRATED	
RELIABILITY (0-8):	8.000
TECHNOLOGY READINESS (0-8):	8.000
PACING TECHNOLOGY PROBLEMS (0-8):	8.000
MISSION MODEL PARAMETERS	
MISSION DURATION, DAYS:	3650.000
RESUPPLY INTERVAL, DAYS:	90.000
METABOLIC LOAD, KW:	2.360
ACQUISITION LOAD, KW:	20.000
RESUPPLY	
RESUPPLY CONSUMABLES, LB:	8.840
RESUPPLY VOLUME, FT3:	2.540
MISSION LIFE CONSUMABLES, LB:	358.511
SUBSYSTEM	
POWER REQUIRED, KW:	.408
POWER SUBSYSTEM IMPACT, LB:	142.626
CONTROL SUBSYSTEM IMPACT, LB:	.000
PROPULSION SUBSYSTEM IMPACT, LB:	24.450
LAUNCH WEIGHT, LB:	659.503
LAUNCH VOLUME, FT3:	9.334
EQUIVALENT LAUNCH WEIGHT, LB:	835.419
MAINTENANCE TIME OVER RESUPPLY INTERVAL, HRS:	2.000
ACQUISITION SURFACE AREA, FT2:	30.870
REJECTION SURFACE AREA, FT2:	117.683
SUBSYSTEM COSTS (FY 87 MILLION DOLLARS)	
DESIGN DEVELOPMENT, TEST AND EVALUATE:	.086
COST OF FLIGHT UNIT, SPARES AND CONSUMABLES FOR INITIAL LAUNCH:	.376
SPARES AND CONSUMABLES TO OPERATE OVER MISSION:	.633
INTEGRATION COST:	.162
PROGRAMMATIC COST:	.323
TRANSPORTATION COSTS FOR SPARES AND CONSUMABLES OVER MISSION:	.559
TRANSPORTATION COSTS FOR FLIGHT UNIT, SPARES AND CONSUMABLES TO OPERATE OVER INITIAL RESUPPLY INTERVAL:	1.069
MAINTENANCE FOR MISSION:	2.839
LIFE CYCLE COSTS FOR MISSION:	6.047

SYSTEM CONFIGURATION: \*DEFAULTS\*

ACQUISITION ASSESSMENT RESULTS

HABITAT 1 MODULE - AUTONOMOUS	
RELIABILITY (0-8):	8.000
TECHNOLOGY READINESS (0-8):	8.000
PACING TECHNOLOGY PROBLEMS (0-8):	8.000
MISSION MODEL PARAMETERS	
MISSION DURATION, DAYS:	3650.000
RESUPPLY INTERVAL, DAYS:	90.000
METABOLIC LOAD, KW:	2.360
ACQUISITION LOAD, KW:	20.000
RESUPPLY	
RESUPPLY CONSUMABLES, LB:	131.920
RESUPPLY VOLUME, FT3:	178.612
MISSION LIFE CONSUMABLES, LB:	5350.089
SUBSYSTEM	
POWER REQUIRED, KW:	.410
POWER SUBSYSTEM IMPACT, LB:	142.626
CONTROL SUBSYSTEM IMPACT, LB:	.000
PROPULSION SUBSYSTEM IMPACT, LB:	24.450
LAUNCH WEIGHT, LB:	1764.143
LAUNCH VOLUME, FT3:	76.606
EQUIVALENT LAUNCH WEIGHT, LB:	2063.139
MAINTENANCE TIME OVER RESUPPLY INTERVAL, HRS:	6.000
ACQUISITION SURFACE AREA, FT2:	30.870
REJECTION SURFACE AREA, FT2:	1114.994
SUBSYSTEM COSTS (FY 87 MILLION DOLLARS)	
DESIGN DEVELOPMENT, TEST AND EVALUATE:	.886
COST OF FLIGHT UNIT, SPARES AND CONSUMABLES FOR INITIAL LAUNCH:	1.012
SPARES AND CONSUMABLES TO OPERATE OVER MISSION:	2.057
INTEGRATION COST:	.664
PROGRAMMATIC COST:	1.328
TRANSPORTATION COSTS FOR SPARES AND CONSUMABLES OVER MISSION:	8.349
TRANSPORTATION COSTS FOR FLIGHT UNIT, SPARES AND CONSUMABLES TO OPERATE OVER INITIAL RESUPPLY INTERVAL:	3.034
MAINTENANCE FOR MISSION:	8.517
LIFE CYCLE COSTS FOR MISSION:	25.847

SYSTEM CONFIGURATION: \*DEFAULTS\*

ACQUISITION ASSESSMENT RESULTS

RELIABILITY (0-8):	8.000
TECHNOLOGY READINESS (0-8):	8.000
PACING TECHNOLOGY PROBLEMS (0-8):	8.000
MISSION MODEL PARAMETERS	
MISSION DURATION, DAYS:	3650.000
RESUPPLY INTERVAL, DAYS:	90.000
METABOLIC LOAD, KW:	16.520
AUTONOMOUS EQUIPMENT LOAD, KW:	20.000
INTEGRATED EQUIPMENT LOAD, KW:	120.000
RESUPPLY	
RESUPPLY CONSUMABLES, LB:	184.960
RESUPPLY VOLUME, FT3:	193.852
MISSION LIFE CONSUMABLES, LB:	7501.156
SUBSYSTEM	
POWER REQUIRED, KW:	2.853
POWER SUBSYSTEM IMPACT, LB:	998.384
CONTROL SUBSYSTEM IMPACT, LB:	.000
PROPULSION SUBSYSTEM IMPACT, LB:	171.151
LAUNCH WEIGHT, LB:	5721.161
LAUNCH VOLUME, FT3:	132.607
EQUIVALENT LAUNCH WEIGHT, LB:	7075.656
MAINTENANCE TIME OVER RESUPPLY INTERVAL, HRS:	18.000
ACQUISITION SURFACE AREA, FT2:	216.089
REJECTION SURFACE AREA, FT2:	1821.090
SUBSYSTEM COSTS (FY 87 MILLION DOLLARS)	
DESIGN DEVELOPMENT, TEST AND EVALUATE:	1.400
COST OF FLIGHT UNIT, SPARES AND CONSUMABLES FOR INITIAL LAUNCH:	3.268
SPARES AND CONSUMABLES TO OPERATE OVER MISSION:	5.854
INTEGRATION COST:	1.634
PROGRAMMATIC COST:	3.268
TRANSPORTATION COSTS FOR SPARES AND CONSUMABLES OVER MISSION:	11.706
TRANSPORTATION COSTS FOR FLIGHT UNIT, SPARES AND CON- SUMABLES TO OPERATE OVER INITIAL RESUPPLY INTERVAL:	9.450
MAINTENANCE FOR MISSION:	25.550
LIFE CYCLE COSTS FOR MISSION:	62.129

SYSTEM CONFIGURATION: \*DEFAULTS\*

TRANSPORT ASSESSMENT RESULTS

RELIABILITY (0-8):	8.000
TECHNOLOGY READINESS (0-8):	8.000
PACING TECHNOLOGY PROBLEMS (0-8):	8.000
MISSION MODEL PARAMETERS	
MISSION DURATION, DAYS:	3650.000
RESUPPLY INTERVAL, DAYS:	90.000
TRANSPORT LOAD, KW:	120.000
RESUPPLY	
RESUPPLY CONSUMABLES, LB:	378.720
RESUPPLY VOLUME, FT3:	.432
MISSION LIFE CONSUMABLES, LB:	15359.200
SUBSYSTEM	
POWER REQUIRED, KW:	2.904
POWER SUBSYSTEM IMPACT, LB:	1016.548
CONTROL SUBSYSTEM IMPACT, LB:	.000
PROPULSION SUBSYSTEM IMPACT, LB:	174.265
LAUNCH WEIGHT, LB:	3275.191
LAUNCH VOLUME, FT3:	75.431
EQUIVALENT LAUNCH WEIGHT, LB:	4844.725
MAINTENANCE TIME OVER RESUPPLY INTERVAL, HRS:	12.000
SUBSYSTEM COSTS (FY 87 MILLION DOLLARS)	
DESIGN DEVELOPMENT, TEST AND EVALUATE:	.300
COST OF FLIGHT UNIT, SPARES AND CONSUMABLES FOR INITIAL LAUNCH:	1.296
SPARES AND CONSUMABLES TO OPERATE OVER MISSION:	3.797
INTEGRATION COST:	.559
PROGRAMMATIC COST:	1.117
TRANSPORTATION COSTS FOR SPARES AND CONSUMABLES OVER MISSION:	23.969
TRANSPORTATION COSTS FOR FLIGHT UNIT, SPARES AND CONSUMABLES TO OPERATE OVER INITIAL RESUPPLY INTERVAL:	5.846
MAINTENANCE FOR MISSION:	17.033
LIFE CYCLE COSTS FOR MISSION:	53.917

SYSTEM CONFIGURATION: \*DEFAULTS\*

REJECTION ASSESSMENT RESULTS

RELIABILITY (0-8):	8.000
TECHNOLOGY READINESS (0-8):	8.000
PACING TECHNOLOGY PROBLEMS (0-8):	8.000
MISSION MODEL PARAMETERS	
MISSION DURATION, DAYS:	3650.000
RESUPPLY INTERVAL, DAYS:	90.000
REJECTION LOAD, KW:	120.000
RESUPPLY	
RESUPPLY CONSUMABLES, LB:	359.760
RESUPPLY VOLUME, FT3:	1056.000
MISSION LIFE CONSUMABLES, LB:	14590.267
SUBSYSTEM	
POWER REQUIRED, KW:	.000
POWER SUBSYSTEM IMPACT, LB:	.000
CONTROL SUBSYSTEM IMPACT, LB:	.000
PROPULSION SUBSYSTEM IMPACT, LB:	.000
LAUNCH WEIGHT, LB:	6252.000
LAUNCH VOLUME, FT3:	374.400
EQUIVALENT LAUNCH WEIGHT, LB:	6611.760
MAINTENANCE TIME OVER RESUPPLY INTERVAL, HRS:	12.000
REJECTION SURFACE AREA, FT2:	5983.866
SUBSYSTEM COSTS (FY 87 MILLION DOLLARS)	
DESIGN DEVELOPMENT, TEST AND EVALUATE:	.500
COST OF FLIGHT UNIT, SPARES AND CONSUMABLES FOR INITIAL LAUNCH:	2.520
SPARES AND CONSUMABLES TO OPERATE OVER MISSION:	4.747
INTEGRATION COST:	1.057
PROGRAMMATIC COST:	2.114
TRANSPORTATION COSTS FOR SPARES AND CONSUMABLES OVER MISSION:	22.769
TRANSPORTATION COSTS FOR FLIGHT UNIT, SPARES AND CONSUMABLES TO OPERATE OVER INITIAL RESUPPLY INTERVAL:	10.579
MAINTENANCE FOR MISSION:	17.033
LIFE CYCLE COSTS FOR MISSION:	61.319

SYSTEM CONFIGURATION: \*DEFAULTS\*

INTEGRATED ASSESSMENT RESULTS

RELIABILITY (0-8):	8.000
TECHNOLOGY READINESS (0-8):	8.000
PACING TECHNOLOGY PROBLEMS (0-8):	8.000
MISSION MODEL PARAMETERS	
MISSION DURATION, DAYS:	3650.000
RESUPPLY INTERVAL, DAYS:	90.000
METABOLIC LOAD, KW:	16.520
AUTONOMOUS EQUIPMENT LOAD, KW:	20.000
INTEGRATED EQUIPMENT LOAD, KW:	120.000
TRANSPORT LOAD, KW:	120.000
REJECTION LOAD, KW:	120.000
RESUPPLY	
RESUPPLY CONSUMABLES, LB:	923.440
RESUPPLY VOLUME, FT3:	1250.284
MISSION LIFE CONSUMABLES, LB:	37450.622
SUBSYSTEM	
POWER REQUIRED, KW:	5.757
POWER SUBSYSTEM IMPACT, LB:	2014.932
CONTROL SUBSYSTEM IMPACT, LB:	.000
PROPULSION SUBSYSTEM IMPACT, LB:	345.417
LAUNCH WEIGHT, LB:	15248.352
LAUNCH VOLUME, FT3:	582.438
EQUIVALENT LAUNCH WEIGHT, LB:	18532.141
MAINTENANCE TIME OVER RESUPPLY INTERVAL, HRS:	42.000
ACQUISITION SURFACE AREA, FT2:	216.089
REJECTION SURFACE AREA, FT2:	7804.955
SUBSYSTEM COSTS (FY 87 MILLION DOLLARS)	
DESIGN DEVELOPMENT, TEST AND EVALUATE:	2.200
COST OF FLIGHT UNIT, SPARES AND CONSUMABLES FOR INITIAL LAUNCH:	7.084
SPARES AND CONSUMABLES TO OPERATE OVER MISSION:	14.398
INTEGRATION COST:	3.249
PROGRAMMATIC COST:	6.499
TRANSPORTATION COSTS FOR SPARES AND CONSUMABLES OVER MISSION:	58.443
TRANSPORTATION COSTS FOR FLIGHT UNIT, SPARES AND CONSUMABLES TO OPERATE OVER INITIAL RESUPPLY INTERVAL:	25.875
MAINTENANCE FOR MISSION:	59.617
LIFE CYCLE COSTS FOR MISSION:	177.365