



---

*Institute of Paper Science and Technology  
Atlanta, Georgia*

---

**IPST Technical Paper Series Number 862**

**In-Plane Moisture Transport in Paper Detected by Magnetic Resonance Imaging**

**J. Leisen, B. Hojjatie, D.W. Coffin, and H.W. Beckham**

**June 2000**

**Submitted to  
Drying Technology: An International Journal**

*Copyright© 2000 by the Institute of Paper Science and Technology*

*For Members Only*

## INSTITUTE OF PAPER SCIENCE AND TECHNOLOGY PURPOSE AND MISSIONS

The Institute of Paper Science and Technology is an independent graduate school, research organization, and information center for science and technology mainly concerned with manufacture and uses of pulp, paper, paperboard, and other forest products and byproducts. Established in 1929 as the Institute of Paper Chemistry, the Institute provides research and information services to the wood, fiber, and allied industries in a unique partnership between education and business. The Institute is supported by 52 North American companies. The purpose of the Institute is fulfilled through four missions, which are:

- to provide a multidisciplinary graduate education to students who advance the science and technology of the industry and who rise into leadership positions within the industry;
- to conduct and foster research that creates knowledge to satisfy the technological needs of the industry;
- to provide the information, expertise, and interactive learning that enables customers to improve job knowledge and business performance;
- to aggressively seek out technological opportunities and facilitate the transfer and implementation of those technologies in collaboration with industry partners.

## ACCREDITATION

The Institute of Paper Science and Technology is accredited by the Commission on Colleges of the Southern Association of Colleges and Schools to award the Master of Science and Doctor of Philosophy degrees.

## NOTICE AND DISCLAIMER

The Institute of Paper Science and Technology (IPST) has provided a high standard of professional service and has put forth its best efforts within the time and funds available for this project. The information and conclusions are advisory and are intended only for internal use by any company who may receive this report. Each company must decide for itself the best approach to solving any problems it may have and how, or whether, this reported information should be considered in its approach.

IPST does not recommend particular products, procedures, materials, or service. These are included only in the interest of completeness within a laboratory context and budgetary constraint. Actual products, materials, and services used may differ and are peculiar to the operations of each company.

In no event shall IPST or its employees and agents have any obligation or liability for damages including, but not limited to, consequential damages arising out of or in connection with any company's use of or inability to use the reported information. IPST provides no warranty or guaranty of results.

The Institute of Paper Science and Technology assures equal opportunity to all qualified persons without regard to race, color, religion, sex, national origin, age, disability, marital status, or Vietnam era veterans status in the admission to, participation in, treatment of, or employment in the programs and activities which the Institute operates.

## **In-plane Moisture Transport in Paper Detected by Magnetic Resonance Imaging**

J. Leisen,<sup>1</sup> B. Hojjatie,<sup>2</sup> D. W. Coffin,<sup>2</sup> and H. W. Beckham<sup>1</sup>

<sup>1</sup>Georgia Institute of Technology, School of Textile and Fiber Engineering

<sup>2</sup>Institute of Paper Science and Technology

Atlanta, GA 30318

[johannes.leisen@tfe.gatech.edu](mailto:johannes.leisen@tfe.gatech.edu), [barry.hojjatie@ipst.edu](mailto:barry.hojjatie@ipst.edu)  
[doug.coffin@ipst.edu](mailto:doug.coffin@ipst.edu), [haskell.beckham@tfe.gatech.edu](mailto:haskell.beckham@tfe.gatech.edu)

submitted to:

*Drying Technology: An International Journal*

# **In-plane Moisture Transport in Paper Detected by Magnetic Resonance Imaging**

J. Leisen,<sup>1</sup> B. Hojjatie,<sup>2</sup> D. W. Coffin,<sup>2</sup> and H. W. Beckham<sup>1</sup>

<sup>1</sup>Georgia Institute of Technology, School of Textile and Fiber Engineering

<sup>2</sup>Institute of Paper Science and Technology

Atlanta, GA 30318

[johannes.leisen@textiles.gatech.edu](mailto:johannes.leisen@textiles.gatech.edu), [barry.hojjatie@ipst.edu](mailto:barry.hojjatie@ipst.edu)

[doug.coffin@ipst.edu](mailto:doug.coffin@ipst.edu), [haskell.beckham@tfe.gatech.edu](mailto:haskell.beckham@tfe.gatech.edu)

Keywords and Phrases: anisotropy; fiber orientation; in-plane moisture diffusion; paper drying; MRI

## **ABSTRACT**

Magnetic resonance imaging was used to visualize in-plane moisture transport in laboratory-made handsheets, heavy paperboard, and polyethylene-coated paperboard. Beginning with wet samples sealed on both surfaces, the moisture content was reduced through evaporation from the outside edges. The diffusion of moisture to the outside edges, i.e., in the plane of the sheets, was found to be isotropic with respect to the sample machine and cross directions. Isotropic in-plane moisture diffusion was observed for samples exhibiting a relatively high degree of fiber orientation, and under conditions of forced convection with air flow rates up to 10 L/min past the outside edges.

## **INTRODUCTION**

Although the diffusion of moisture in paper impacts many aspects of papermaking, converting, and end use, some basic questions about the behavior of moisture transport in paper remain unanswered. The purpose of this study was to assess the degree of anisotropy in the in-plane diffusion properties of paper. In-plane transport of moisture may impact the drying of wide sheets or webs because edges typically dry slightly faster. In-plane diffusion certainly plays a large role in the sorption behavior of rolls and stacks of paper. For products such as polyethylene-coated board, the in-plane diffusion properties will dominate the sorption behavior. Little work has been completed on the in-plane diffusion characteristics of paper. No study of the in-plane anisotropy of diffusion properties has been reported. The diffusion properties could be different in the

machine direction (MD), cross direction (CD), and the normal to the paper plane directions (ZD) due to the fiber network structure.

Hashemi et al. [1997] found indications that the in-plane moisture diffusion was faster than ZD diffusion. In addition, results from measurements of in-plane and ZD moisture permeability in linerboard and TMP handsheets reported by Lindsay and Wallin [1990] have shown that the in-plane permeability for these papers can be between 2 and 10 times greater than the corresponding ZD component.

In the following, results using nuclear *magnetic resonance imaging* (MRI) of the in-plane diffusion of moisture within paper sheets are reported.

## **EXPERIMENTAL APPROACH: MRI**

The use of nuclear magnetic resonance imaging provides a means to observe the movement of moisture in real time. The technique is especially useful since it allows not only the visualization or determination of a spatial moisture distribution, but also the measurement of the physico-chemical properties of moisture bound to a substrate.

The principles of MRI with special emphasis on the application to paper have been introduced by Bernada et al. [1998b]. More detailed information can be found in various references (Callaghan, [1991]; Blümler, et al., [1996] and Xia, [1996]). In general, MRI is only able to detect liquid molecules. Gaseous molecules occur in concentrations which are too low to be detected by MRI and often exhibit very long nuclear relaxation times ( $T_1$ ) (Blümler, [1997]). Molecules in the solid state exhibit such short  $T_2$  relaxation times that it is not possible to detect them using routine MRI techniques. However, specialized techniques exist that allow the detection of gaseous and solid matter by MRI methods (Blümler, [1997]). An application of MRI to characterize moisture diffusion in pulp pads was reported by Nilsson [1996] and Bernada et al. [1998a, 1998b]. The drying behavior of pulp products during a simulated industrial drying process was investigated by measuring the moisture distribution in pulp pads.

In this experimental study, MRI was used to visualize the desorption of moisture along the MD and CD directions of a paper sheet, and to investigate potential effects of the fiber orientation on the diffusion of moisture.

## **MATERIALS AND METHODS**

### **Paper Specimens**

In-plane diffusion of moisture was studied for several laboratory-made and machine-made paper and paperboard samples as summarized in Table I. The laboratory hand sheets were produced on a Formette Dynamique from a southern softwood pine bleached kraft (SWBK) pulp, refined to a Canadian Standard Freeness of 519 CSF in a Valley beater. Two 407-g/m<sup>2</sup> sheets were formed using the Formette Dynamique sheet

former and pressed together between blotter papers at a pressure of 50 psi for five minutes to form a single 2-ply sheet with a basis weight of 814 g/m<sup>2</sup>. The 2-ply handsheet was restrain-dried and then stored in a conditioned room at a constant relative humidity of 50% and a temperature of 22°C.

In addition to the laboratory-made handsheets, a commercial paperboard and a polyethylene-coated paperboard were examined. Paperboard, also called tablet board, is a relatively heavy paper suitable for note-pad backing. It is made by wet pressing several layers of lighter sheets. The polyethylene-coated paperboard exhibits increased liquid resistance and is used for juice or milk containers.

For the MRI experiments, circular samples with diameters of 1.7 cm were cut from the sheets. A summary of the physical and mechanical properties of the samples analyzed in these experiments is shown in Table I.

**TABLE I. Physical and Mechanical Properties of Paper Sheets Studied.**

Sample	Thickness (mm)	Areal density (g/m <sup>2</sup> )	Apparent density (g/m <sup>3</sup> )	Ratio of sonic moduli, MD/CD
1-ply handsheet	2.10	792	0.38	1.7
2-ply handsheet	1.29	814	0.63	2.7
paperboard	1.51	920	0.61	6.8
polyethylene-coated paperboard	0.53	404	0.76	2.2

### MRI Experiments

All experiments were performed using a Bruker DSX nuclear magnetic resonance (NMR) spectrometer with micro-imaging accessory operating at a magnetic field of 9.4 Tesla. The experiments are based on the spin-echo sequence (Callaghan, [1991]) and the parameters TE (echo time) and TR (recovery time) are given in the respective figure captions. A special assembly made of glass and Teflon, as described below, was used to ensure reproducible conditions of moisture desorption. It was designed to be used with an MRI probe containing a 25-mm rf coil inserted into a vertical-bore magnet. The 90-degree pulse length achieved with this coil was 50 μs. In all cases, experiments were performed using rectangular rf pulses and gradients were always switched off during the application of these pulses. Therefore, no slice selection was employed and the imaging plane corresponds to the respective sample thickness. In other words, the recorded 2D images represent moisture contained within the entire sample. This approach leads to optimal signal-to-noise ratios since all detectable nuclear spins within the sample are contributing to the magnetic resonance (MR) image; however, information about the moisture distribution in the ZD direction is not obtained. Since only a two-dimensional diffusion problem is considered, the lack of the full three-dimensional moisture

distribution does not pose a problem. MRI data were analyzed using the Bruker spectrometer software package, ParaVision.

In-plane moisture movement was investigated using several desorption scenarios. Circular samples were pre-conditioned at a given moisture content and then exposed to an environment that would cause a moisture change. As shown in Figure 1, the sample was placed between two Teflon-coated glass rods in the MRI detection coil so that during the drying experiments moisture could leave the sample only through the edges. A flow of dry air at a rate of 10 L/min was blown along the glass rods to ensure equal exposure of the entire radial edge of the sample.

The primary direction of fiber orientation (MD axis) was marked in the MR images by placing a small rectangular piece of silicone rubber next to the sample with the long axis of the rectangle parallel to the MD. This rubber marker provided a signal just above the noise level and is not apparent in the images presented below.

The parameters of the MRI spin-echo experiment were chosen such that the signals detected were nearly proportional to the moisture contents measured by gravimetric methods. However, as has been shown by Bernada et al. [1998], the MR signal intensity is not necessarily proportional to the actual moisture content at different locations in an MR image. Calibration curves can be constructed to relate MR signal intensity to moisture content, but strong deviations from linearity are typically observed for low moisture contents (< 10%, depending on the sample). While Bernada et al. [1998] attributed this deviation to a shrinkage effect, it is due to changes in the  $T_2$  relaxation behavior exhibited by moisture located in the smallest pores near the end of a drying process [Leisen, 2000]. For the paper samples investigated in this study, moisture contents below 6% would not give any detectable MR signal. Hence, for images where the moisture content is represented using a gray scale, black areas correspond to moisture contents below 6%. Moisture contents above 6% are depicted by increasing levels of brightness within the grayscale.

If moisture diffusion is strongly dependent on the fiber orientation, the moisture should exhibit an elliptical distribution within the plane of the samples as it desorbs. If the diffusion process is isotropic, moisture will leave the sample at equal rates for all orientations with respect to the sample machine and cross directions, leading to circular moisture distributions. Hence, anisotropy of diffusion may be quantified by analyzing shapes of the drying patterns as a function of time. For the initial analysis, signal contrast caused by changes in nuclear relaxation times does not play a significant role since only the shape of the desorption pattern observed as an MR image is pertinent.

## RESULTS AND DISCUSSION

Figure 2 displays a typical series of MR images recorded during the drying of a circular paper sample. In this case the sample (2-ply handsheet) was soaked in water and then pressed to an initial moisture content of 134%. The time required to measure one

image was 8.5 minutes, so that each image represents the time-averaged moisture distribution over this period. The first image in the series shows a high intensity response for the entire sheet, which reflects the high initial moisture content. Subsequent images show annular patterns of reduced intensity as the sample dries from the outside edge. It is evident from the figure that no pronounced elliptical patterns were formed.

Figure 3 illustrates moisture desorption from a sample (2-ply handsheet) for which the upper glass cylinder (shown in Figure 1) was removed, and the edges of the sample were sealed with Teflon tape. Thus, moisture could only exit through the top surface. The initial moisture content for this experiment was 103%. The series of images given in Figure 3 show that while the intensity decreases with time, the center-to-edge in-plane moisture gradients are not as pronounced or persistent as those observed for the previous samples in which moisture had to diffuse to the edges to exit the sample. Note that the amount of time required to complete this experiment (289 min) is significantly shorter than that for the case of Figure 2 (484 min). This is because of the different path lengths for moisture transport, radius versus thickness. Direct comparison of the diffusion times is not warranted because of different airflow conditions along the free surfaces.

By superimposing circles on the time series of images for in-plane diffusion (Figure 2), the images were found to be circular within experimental error. Any deviation of the patterns from a circular shape was below a detection limit governed partly by the signal-to-noise ratio within the images and partly by calibration of the gradients used for the MRI experiment. A visual fit of the intensity images using ellipses yielded the major and the minor axes of the ellipses to be within 10% of each other, where none of the principal axes were aligned with the MD or CD direction.

The drying experiments described in Figure 2 were repeated three times for the laboratory-made 2-ply handsheets. In all cases, circular drying patterns resembling those of Figure 2 were observed. In order to test the generality of these findings, moisture desorption from the following different types of papers were measured: 1-ply Formette Dynamique handsheet, paperboard (i.e., tablet board), and polyethylene-coated paperboard. For all samples, no indication of anisotropic moisture diffusion was found. Reducing the airflow to 5 L/min or complete interruption of the airflow affected the drying times, but not the shape of the MR images. Beginning with a sample exposed to a 90% relative humidity environment, desorption patterns similar to those in Figure 2 were also observed, except with reduced overall intensities due to the lower initial moisture content (20%). Thus, for moisture diffusion in paper driven by changes in relative humidity, circular desorption patterns indicate an isotropic diffusion process with respect to the sample machine and cross directions. It should be emphasized, however, that these MRI results were obtained using relatively small samples (1.7-cm diameters). In a recent study, Hojjatie et al. [2000] determined the surface moisture distribution in paper materials using infrared thermography. This technique is currently being employed to determine whether such an isotropic diffusion pattern exists for surface moisture in larger paper samples.

## CONCLUSION

For the samples investigated in this study, the moisture distribution during desorption was not affected by the degree of fiber orientation or air flow rate up to 10 L/min. These findings are based only on a small set of different samples. However, circular desorption patterns were observed under all conditions examined, indicating no detectable anisotropy of in-plane moisture diffusion. It appears that moisture diffusion in paper, at least for fiber distributions up to a sonic moduli MD/CD ratio of 6.8, are isotropic in the plane of the sheet over circular areas of 2.3 cm<sup>2</sup>.

## ACKNOWLEDGMENTS

The research described here was supported through a seed grant program jointly administered by Georgia Tech and the Institute of Paper Science and Technology. Access to NMR instrumentation has been made possible by a NSF DMR instrumentation grant (DMR-9503936).

## REFERENCES

- Bernada, P.; Stenström, S.; and Månsson, S.; 1998a, "Experimental Study of the Moisture Distribution Inside a Pulp Sheet using MRI. Part I: Principles of the MRI Technique", *J. Pulp and Paper Sci.*, **24**(12), pp 373-379.
- Bernada, P.; Stenström, S.; and Månsson, S.; 1998b, "Experimental Study of the Moisture Distribution Inside a Pulp Sheet using MRI. Part II: Drying Experiments", *J. Pulp and Paper Sci.*, **24**(12), pp 380-387.
- Blümmler, P.; Blümich, B.; Botto, R.; and Fukushima, E. (Eds.); 1997, "Spatially Resolved Magnetic Resonance, Methods, Materials, Medicine, Biology, Rheology, Geology, Ecology, Hardware", Wiley-VCH, Weinheim.
- Callaghan, P.; 1991, "Principles of Nuclear Magnetic Resonance Microscopy", Clarendon Press, Oxford.
- Hashemi, S. J.; Gomes, V. G.; Crotogino, R. H.; and Douglas, W. J. M.; 1997, "In-plane Diffusivity of Moisture in Paper", *Drying Technology*, **15**(2), pp 265-294.
- Hojjatie, B.; Abedi, J.; and Coffin, D. W.; 2000, "Infrared Thermography as a Tool for Measuring In-plane Moisture Distribution in Paper", *TAPPI Journal*, submitted.

Leisen, J.; and Beckham, H. W.; 2000, "Experimental Considerations for the Application of Magnetic Resonance Imaging in the Textile Sciences", *Textile Research Journal*, submitted.

Lindsay, J. D.; and Wallin, J. R.; 1990, "Characterization of In-plane Flow in Paper", *For. Prod. Symp.*, pp 121-129.

Nilsson, L.; Månsson, S.; and Steinström, S.; 1996, "Measuring Moisture Gradient in Cellulose Fibre Networks: An Application of Magnetic Resonance Imaging", *J. Pulp and Paper Sci.*, **22**(2), pp J48-J52.

Xia, Y.; 1996, "Contrast in NMR Imaging and Microscopy", *Concepts in Magnetic Resonance*, **8**(3), pp 205-225.

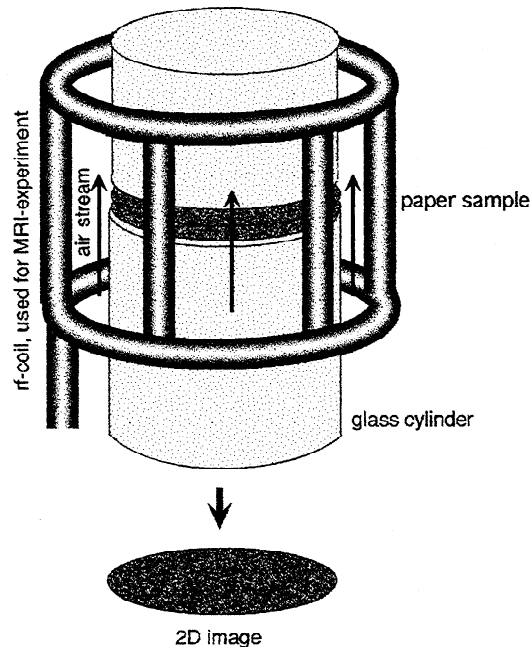

FIGURE 1. Experimental setup to observe the in-plane diffusion of moisture in paper during drying experiments using a two-dimensional magnetic resonance (MR) imaging technique. Since moisture can only leave the paper samples from the outside edges, it must diffuse in the plane during a drying process.

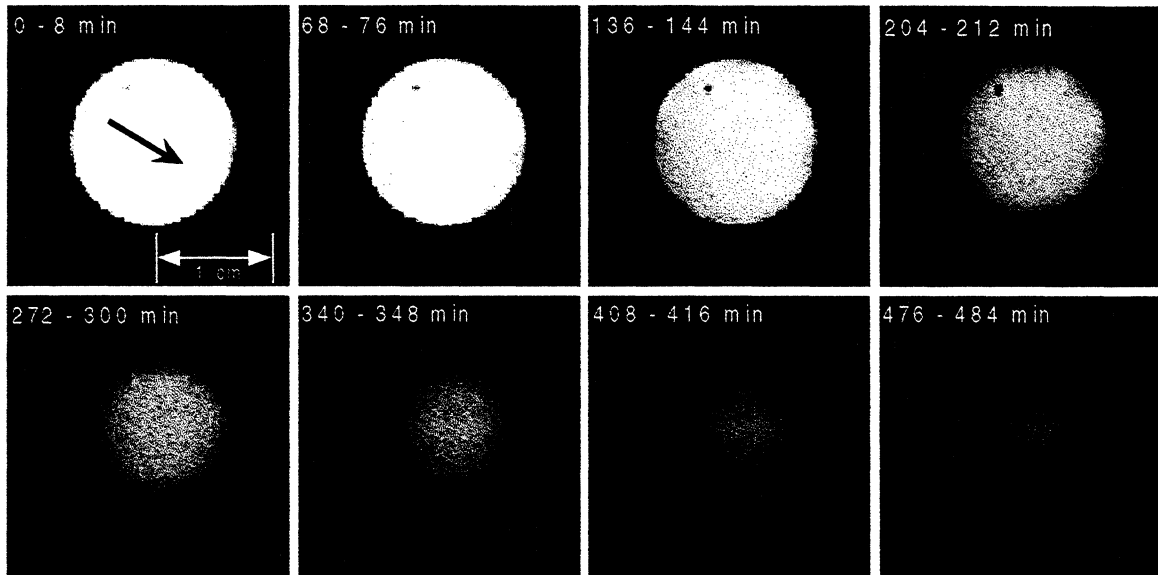

FIGURE 2. Series of 2D magnetic resonance images measured during a drying experiment using the setup shown in Figure 1 ( $TE = 2.1$  ms,  $TR = .5$  s). The arrow in the top-left image signifies the machine direction of the paper sample. The sample in this case was a 2-ply laboratory-made handsheet with an initial moisture content of 134%.

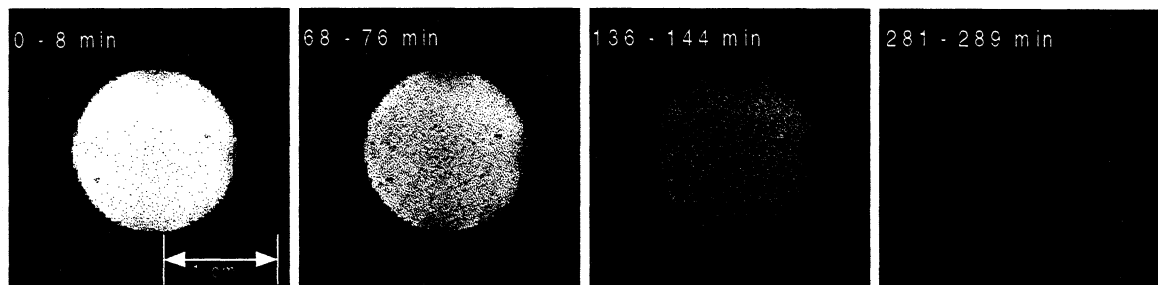

FIGURE 3. Series of 2D magnetic resonance images measured during a drying experiment in which the upper glass cylinder depicted in Figure 1 was removed and the sample edges were sealed with Teflon tape. Thus, moisture could evaporate from the sample surface ( $TE = 2.1$  ms,  $TR = .5$  s). The sample in this case was a 2-ply laboratory-made handsheet with an initial moisture content of 103%.



