



US010630207B2

(12) **United States Patent**
Wang et al.

(10) **Patent No.:** **US 10,630,207 B2**

(45) **Date of Patent:** **Apr. 21, 2020**

(54) **TRIBOELECTRIC NANOGENERATOR FOR HARVESTING BROADBAND KINETIC IMPACT ENERGY**

(71) Applicant: **Georgia Tech Research Corporation**,
Atlanta, GA (US)

(72) Inventors: **Zhong Lin Wang**, Atlanta, GA (US);
Xiaonan Wen, Atlanta, GA (US);
Weiqing Yang, Atlanta, GA (US)

(73) Assignee: **Georgia Tech Research Corporation**,
Atlanta, GA (US)

(*) Notice: Subject to any disclaimer, the term of this patent is extended or adjusted under 35 U.S.C. 154(b) by 0 days.

(21) Appl. No.: **16/540,882**

(22) Filed: **Aug. 14, 2019**

(65) **Prior Publication Data**

US 2019/0372482 A1 Dec. 5, 2019

Related U.S. Application Data

(62) Division of application No. 15/159,225, filed on May 19, 2016, now Pat. No. 10,425,018.
(Continued)

(51) **Int. Cl.**
H02N 2/18 (2006.01)
H02N 1/04 (2006.01)
(Continued)

(52) **U.S. Cl.**
CPC **H02N 1/04** (2013.01)

(58) **Field of Classification Search**
CPC .. H02N 2/22; H02N 2/18; H02N 1/04; H02N 1/00

See application file for complete search history.

(56) **References Cited**

U.S. PATENT DOCUMENTS

3,086,131 A * 4/1963 Ballentine H02N 1/04
310/310
4,126,822 A * 11/1978 Wahlstrom G04C 10/00
310/309

(Continued)

FOREIGN PATENT DOCUMENTS

CN 107453644 A * 12/2017 H02N 1/04
WO WO-2014193182 A1 * 4/2014 H02N 1/04
WO WO-2014169724 A1 * 10/2014 H02N 1/04

OTHER PUBLICATIONS

Yuanjie et al., Hybrid triboelectric nanogenerator for harvesting water wave energy and as a self-powered distress signal emitter, 2014, www.elsevier.com/locate/nanoenergy (Year: 2014).*

Primary Examiner — Edgardo San Martin

(74) *Attorney, Agent, or Firm* — Bryan W. Bockhop;
Bockhop Intellectual Property Law, LLC

(57) **ABSTRACT**

A triboelectric generator includes a first triboelectric member, which includes a first conductive layer and an insulating triboelectric material layer disposed on the first conductive layer. The triboelectric material layer includes a first material having a first position on a triboelectric series. An elastic member, disposed against the triboelectric material layer of the triboelectric member and includes a second conductive material, has an elasticity that results in the elastic member being deformed when compressed and returning to an original non-deformed shape after being compressed. The second conductive material has a second position on the triboelectric series. A first load is coupled to the first conductive layer and with the second conductive material so that when a force compresses the elastic member charges will flow between the first conductive layer and the second conductive layer through the load.

7 Claims, 5 Drawing Sheets

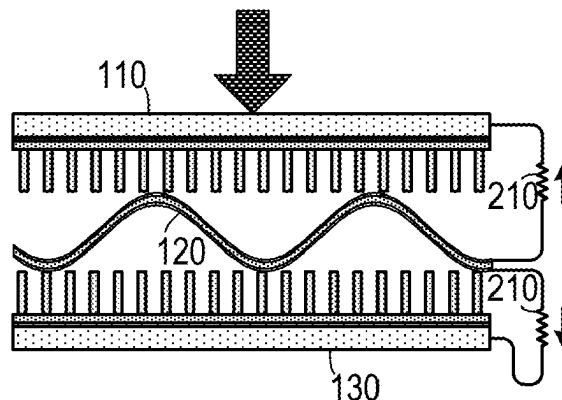
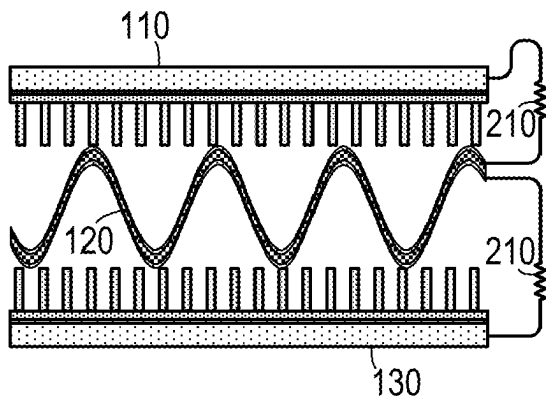

Related U.S. Application Data

(60) Provisional application No. 62/163,692, filed on May 19, 2015.

(51) **Int. Cl.**

H02N 2/00 (2006.01)
H02N 1/00 (2006.01)

(56)

References Cited

U.S. PATENT DOCUMENTS

4,990,813 A * 2/1991 Paramo H02N 1/04
 310/308
 8,193,655 B2 * 6/2012 Roberts H01L 41/22
 290/53
 8,536,760 B1 * 9/2013 Kim, II H02N 11/002
 310/309
 9,178,446 B2 * 11/2015 Wang H02N 1/04
 9,490,306 B2 * 11/2016 Kim H01L 27/3225
 9,543,860 B2 * 1/2017 Wang H02N 1/04
 9,595,892 B2 * 3/2017 Takahashi H02N 1/004
 9,595,894 B2 * 3/2017 Wang H02N 1/04
 9,825,558 B2 * 11/2017 Zhang H02N 1/04
 9,887,644 B2 * 2/2018 Kim H02N 1/04

9,906,170 B2 * 2/2018 Choi H02N 1/04
 9,921,678 B2 * 3/2018 Wang H03K 17/9643
 9,985,554 B2 * 5/2018 Wang H02N 1/04
 2011/0050181 A1 * 3/2011 Post H02N 1/04
 320/166
 2013/0020909 A1 * 1/2013 Kim H02N 2/18
 310/339
 2014/0300248 A1 * 10/2014 Wang G01L 9/0072
 310/300
 2015/0363019 A1 * 12/2015 Schediwy G06F 3/044
 345/174
 2016/0028327 A1 * 1/2016 Aliane B05D 5/02
 310/300
 2016/0040648 A1 * 2/2016 Wang F03B 13/14
 290/42
 2016/0065091 A1 * 3/2016 Wang H02N 1/04
 310/300
 2016/0218640 A1 * 7/2016 Wang H02N 1/04
 2016/0336505 A1 * 11/2016 Arizumi H01L 41/113
 2016/0373028 A1 * 12/2016 He H02N 1/04
 2017/0331397 A1 * 11/2017 Kim H02N 1/04
 2017/0370352 A1 * 12/2017 Fujita B81B 5/00
 2018/0024668 A1 * 1/2018 Byun G02F 1/0136
 345/174
 2018/0123482 A1 * 5/2018 Kim H02N 1/04

* cited by examiner

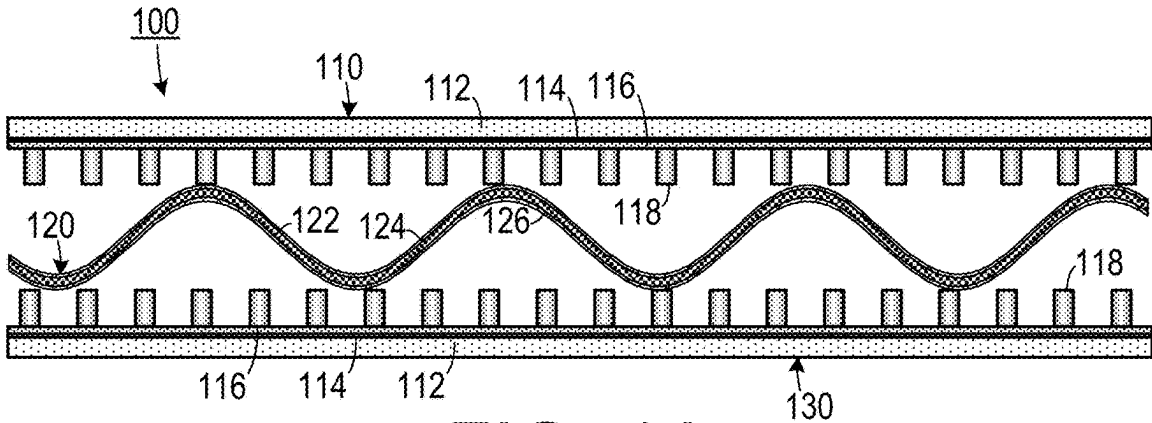

FIG. 1A

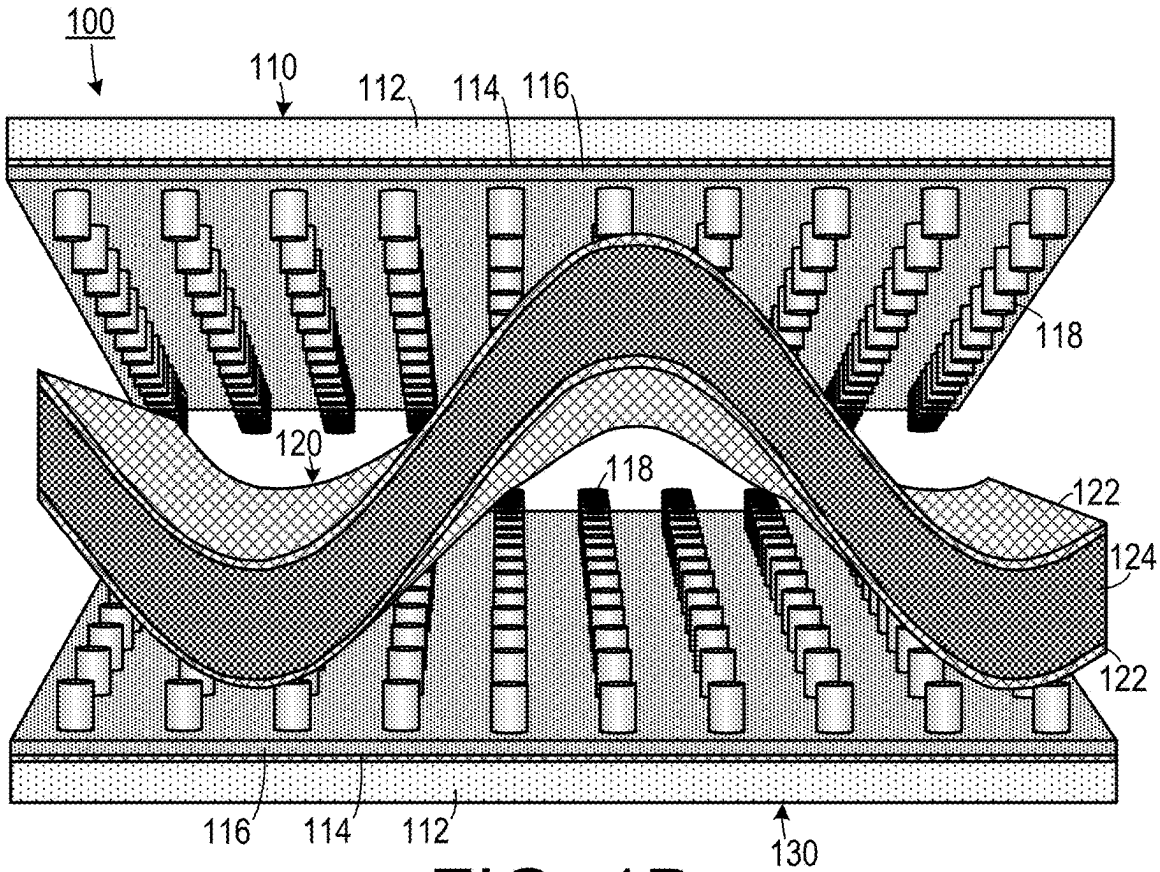

FIG. 1B

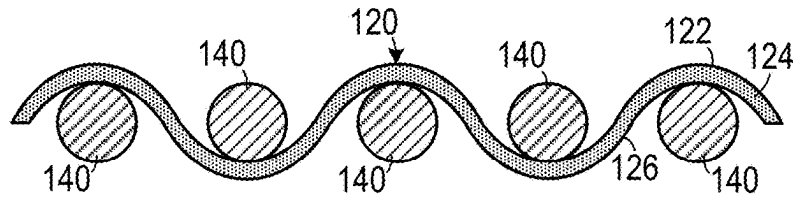

FIG. 1C

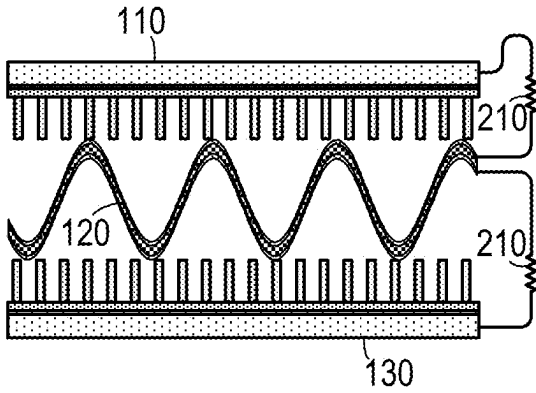

FIG. 2A

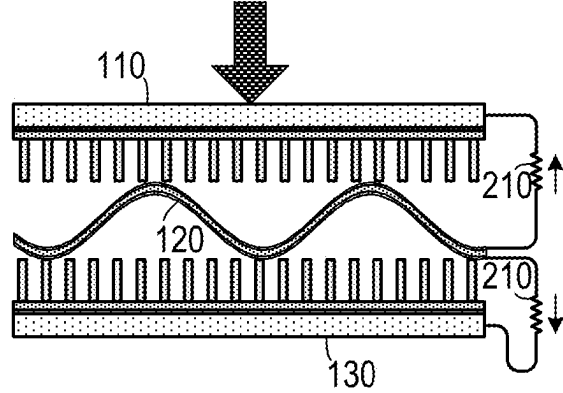

FIG. 2B

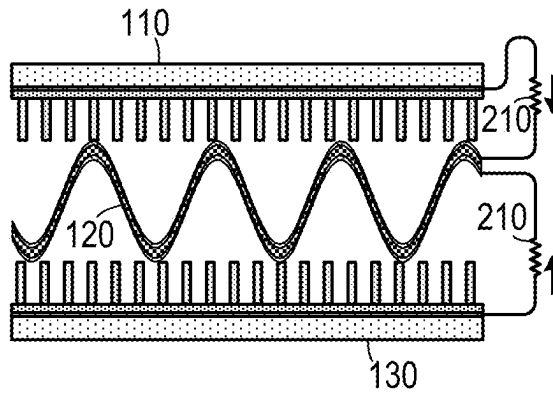

FIG. 2C

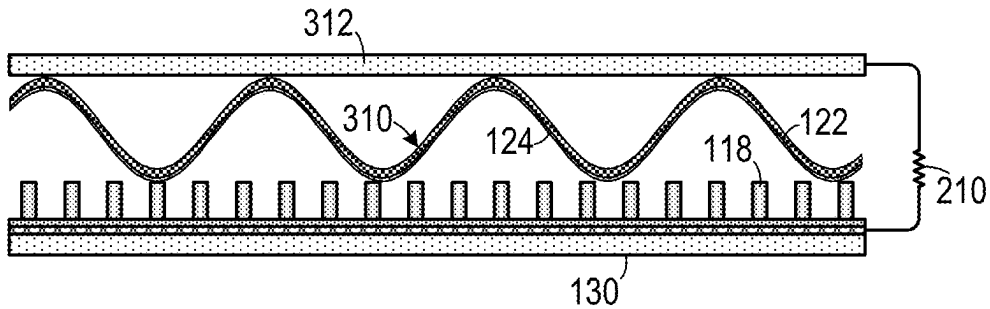

FIG. 3

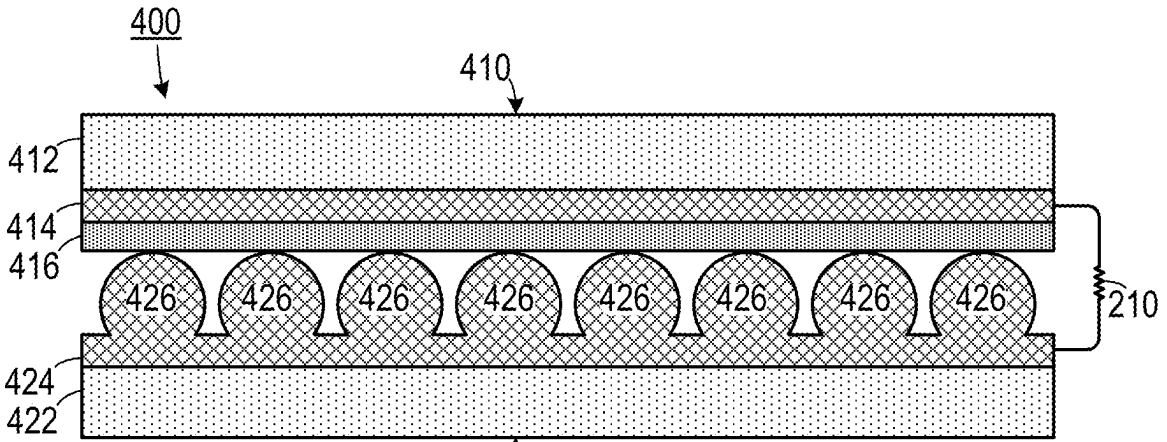

FIG. 4A

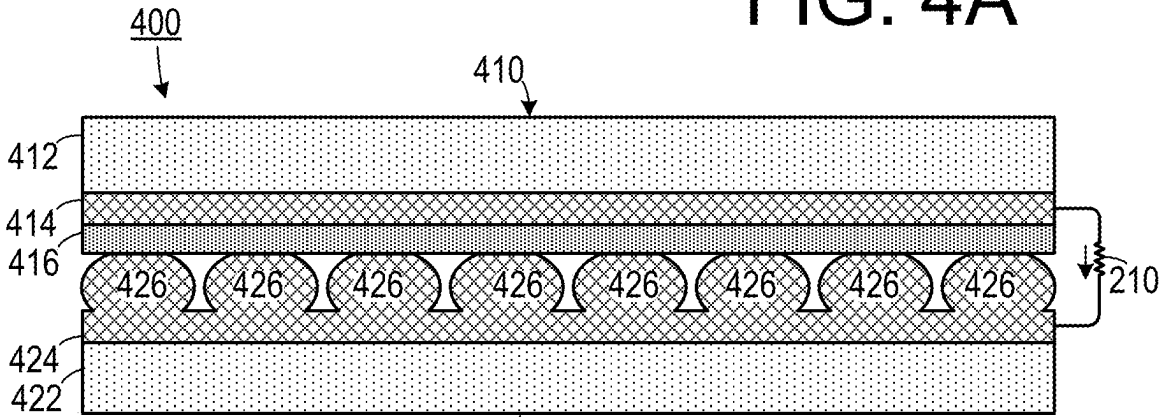

FIG. 4B

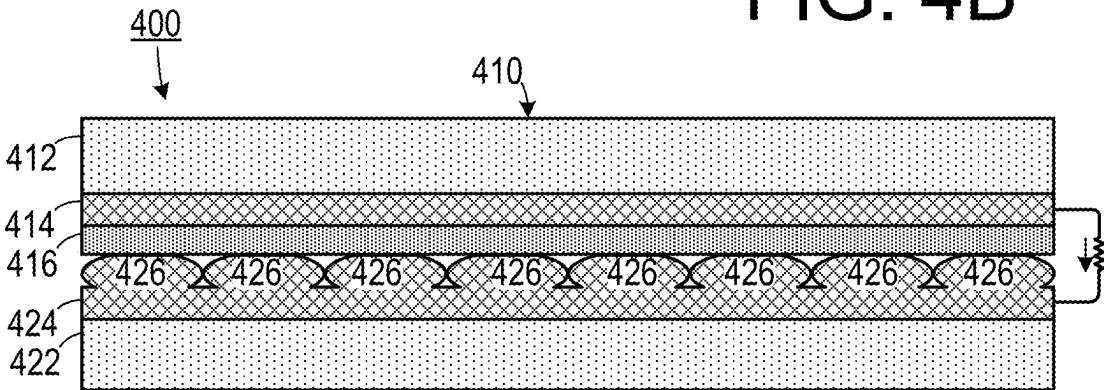

FIG. 4C

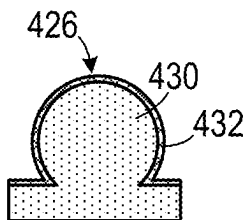

FIG. 4D



FIG. 5A

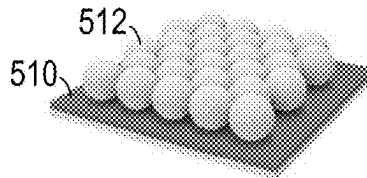

FIG. 5B

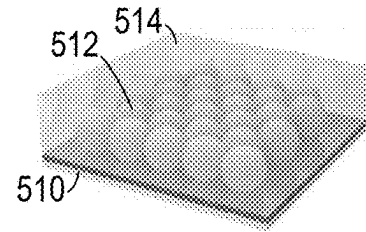

FIG. 5C

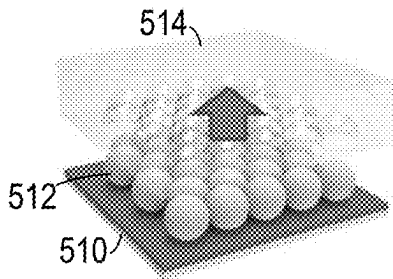

FIG. 5D

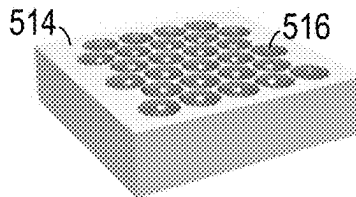

FIG. 5E

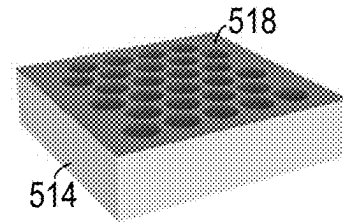

FIG. 5F

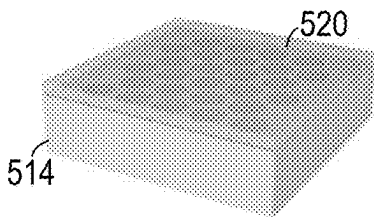

FIG. 5G

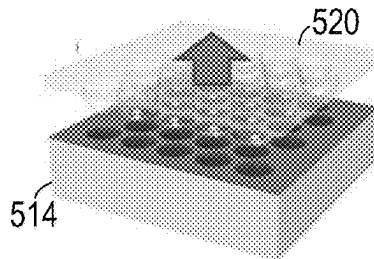

FIG. 5H

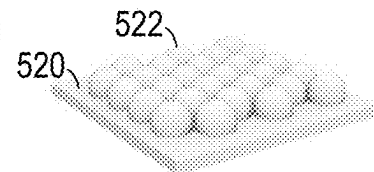

FIG. 5I

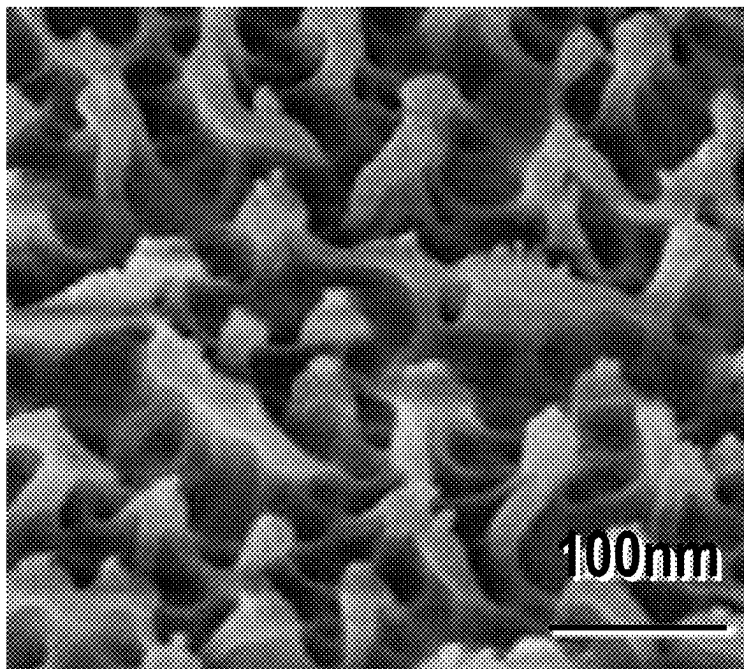

FIG. 6

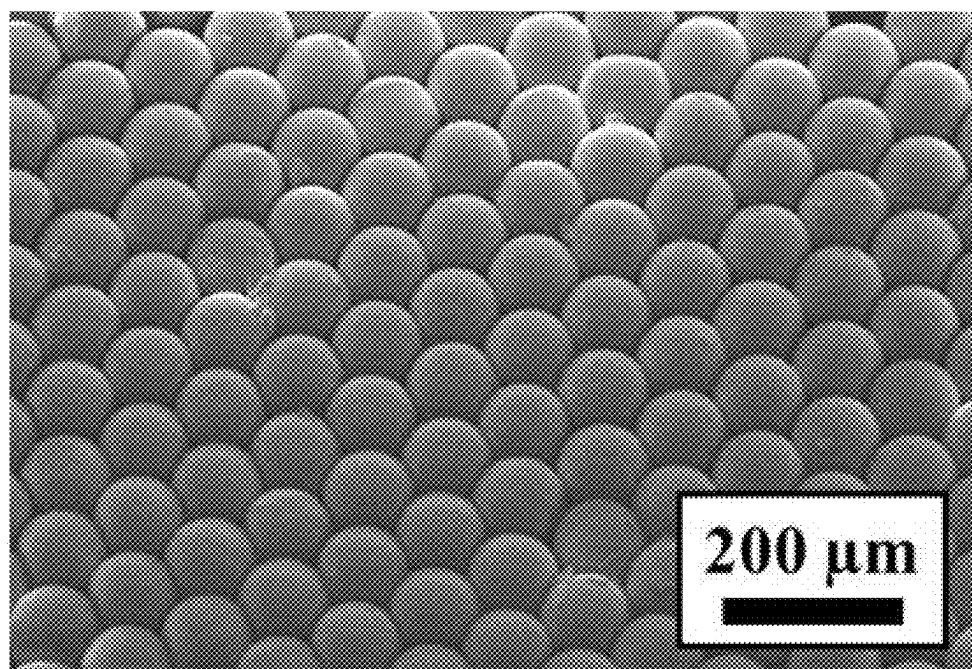

FIG. 7

TRIBOELECTRIC NANOGENERATOR FOR HARVESTING BROADBAND KINETIC IMPACT ENERGY

CROSS-REFERENCE TO RELATED APPLICATION(S)

This application is a divisional of and claims the benefit of U.S. patent application Ser. No. 15/159,225, filed May 19, 2016, which is a non-provisional of U.S. Provisional Patent Application Ser. No. 62/163,692, filed May 19, 2015, the entirety of each of which is hereby incorporated herein by reference.

STATEMENT OF GOVERNMENT INTEREST

This invention was made with government support under agreement No. DE-FG02-07ER46394, awarded by the Department of Energy. The government has certain rights in the invention.

BACKGROUND OF THE INVENTION

1. Field of the Invention

The present invention relates to generators and, more specifically, to a system for generating voltage and current using the triboelectric effect.

2. Description of the Related Art

Energy harvesting by converting ambient energy into electricity may offset the reliance of small portable electronics on traditional power supplies, such as batteries. When long-term operation of a large number of electronic devices in dispersed locations is required, energy harvesting has the advantages of outstanding longevity, relatively little maintenance, minimal disposal and contamination.

When two materials, at least one of which is non-conducting, come into contact with each other, a chemical bond, known as adhesion, is formed between the two materials. Depending on the triboelectric properties of the materials, one material may "capture" some of the electrons from the other material. If the two materials are separated from each other, a charge imbalance will occur. The material that captured the electron will negatively charged and the material that lost an electron will be positively charged. This charge imbalance gives rise to what is sometimes referred to as "static electricity." The term "static" in this case is somewhat deceptive, as it implies a lack of motion when in reality motion is necessary for charge imbalances to flow. The spark one feels upon touching a door knob is an example of such flow.

The triboelectric effect is a type of contact electrification in which certain materials become electrically charged after they come into contact with another such as through friction. It is the mechanism through which static electricity is generated. The triboelectric effects associated electrostatic phenomena are the most common electrical phenomena in daily life, from walking to driving. However, the triboelectric effect has been largely ignored as an energy source for electricity. Some electrostatic micro-generators have been developed and used in research relating to micro-electromechanical systems (MEMS), but such designs rely on an extra voltage source to charge electrode plates instead of harnessing triboelectric effect, leading to complicated structures and fabrication processes.

Previously demonstrated triboelectric generators require periodic contact and vertical separation of two materials that have opposite triboelectric polarities, making it only applicable to harvest energy from intermittent impact or shock. Such systems typically include a cavity with a constantly changing volume, which makes packaging difficult and limits applications in atmospheres with high humidity, corrosive chemicals or gases, and in water or other liquids.

Mechanisms using piezoelectric, electrostatic or electromagnetic principles to harvest energy from random vibrations, wind flow, air pressure, or human body motions have been developed and applied as generators or self-powered sensors. Recently, the development of triboelectric nanogenerators (triboelectric generators) offers a new paradigm for fabricating high-output and cost effective generators for driving small electronics. Reciprocating motion is a very common mechanical motion occurs in natural oscillations, motion of waves, swing of human limbs, and mechanical piston movements, etc. Features of these motions that include long reciprocating distance, low frequencies and amplitude or frequency fluctuations pose challenges for previously developed vibration-harvesters, which were only suited to low-amplitude and high-frequency excitations induced by inertia forces.

Therefore, there is a need for a reliable, small and easily manufactured system for harvesting triboelectric energy from reciprocating motion.

SUMMARY OF THE INVENTION

The disadvantages of the prior art are overcome by the present invention which, in one aspect, is a triboelectric generator that includes a first triboelectric member. The first triboelectric member includes a first conductive layer and an insulating triboelectric material layer disposed on the first conductive layer. The triboelectric material layer includes a first material that has a first position on a triboelectric series. An elastic member is disposed against the triboelectric material layer of the triboelectric member and includes a second conductive material. The elastic member has an elasticity that results in the elastic member being deformed when compressed and returning to an original non-deformed shape after being compressed. The second conductive material has a second position, different from the first position, on the triboelectric series. A first load is in electrical communication with the first conductive layer and with the second conductive material so that when a force drives the first triboelectric member against the elastic member, thereby compressing the elastic member, and after the force is released from the first triboelectric member, charges will flow between the first conductive layer and the second conductive layer through the load.

In another aspect, the invention is an electrical generator that includes a first triboelectric member, which includes a first conductive layer and a triboelectric material layer disposed on the first conductive layer. The triboelectric material layer includes a plurality of nanoscale protrusions extending outwardly therefrom. The triboelectric material layer includes a first material that has a first position on a triboelectric series. An elastic member has an undulated shape and is disposed against the triboelectric material layer of the triboelectric member. The elastic member includes a dielectric layer and a second conductive layer disposed on the dielectric layer. The dielectric layer has an elasticity that results in the elastic member returning to the undulated shape after being compressed. The second conductive layer includes a second material that has a second position,

3

different from the first position, on the triboelectric series. A first load is in electrical communication with the first conductive layer and with the second conductive layer so that when a force drives the first triboelectric member against the elastic member, thereby compressing the elastic member, and after the force is released from the first triboelectric member charges will flow between the first conductive layer and the second conductive layer through the load. A second triboelectric member is spaced apart from the first triboelectric member and includes a fourth conductive layer and a triboelectric material layer that is disposed on the third conductive layer. The triboelectric material layer includes a plurality of nanoscale protrusions extending outwardly therefrom. The triboelectric material layer includes the first material. The second triboelectric member is disposed so that the plurality of nanoscale protrusions of the first triboelectric member face the plurality of nanoscale protrusions of the second triboelectric member and so that the elastic member is disposed there-between. A fourth conductive layer is disposed on the dielectric layer opposite from the second conductive layer. A second load is in electrical communication with the third conductive layer and with the fourth conductive layer.

In yet another aspect, the invention is a method of making a triboelectric generator, in which a first conductive layer is applied on a selected surface of a first substrate. A triboelectric material is applied on the conductive layer. The triboelectric material layer includes a first material that has a first position on a triboelectric series. Application of the triboelectric material to the conductive layer generates a first triboelectric member. An elastic member is generated by applying a second conductive layer is applied to a dielectric elastic material having a predefined shape. The second conductive layer includes a second material that has a second position, different from the first position, on the triboelectric series. The dielectric elastic material has an elasticity that results in the elastic member returning to the predefined shape after being compressed. The second conductive layer of the elastic member is placed against the triboelectric material of the first triboelectric member. A load is electrically coupled between the first conductive layer and the second conductive layer.

These and other aspects of the invention will become apparent from the following description of the preferred embodiments taken in conjunction with the following drawings. As would be obvious to one skilled in the art, many variations and modifications of the invention may be effected without departing from the spirit and scope of the novel concepts of the disclosure.

BRIEF DESCRIPTION OF THE FIGURES OF THE DRAWINGS

FIGS. 1A-1B are schematic diagrams showing an embodiment of a triboelectric generator with an undulated elastic member.

FIG. 1C is a schematic diagram showing one method of forming an undulated elastic member.

FIGS. 2A-2C is a series of schematic diagrams demonstrating current generation with a device according to the embodiment shown in FIGS. 1A-1B.

FIG. 3 is a schematic diagram of a triboelectric generator employing a single triboelectric member.

FIGS. 4A-4C is a series of schematic diagrams showing an embodiment employing an elastic member with partial spheres and operation of this embodiment.

4

FIG. 4D is a cross-sectional diagram of a partial sphere employed in an elastic member.

FIGS. 5A-5I is a series of schematic diagrams demonstrating one method of making an elastic member employing partial spheres.

FIG. 6 is a micrograph of a nanoscale protrusions extending outwardly from a triboelectric material.

FIG. 7 is a micrograph of an elastic member employing partial spheres.

DETAILED DESCRIPTION OF THE INVENTION

A preferred embodiment of the invention is now described in detail. Referring to the drawings, like numbers indicate like parts throughout the views. Unless otherwise specifically indicated in the disclosure that follows, the drawings are not necessarily drawn to scale. As used in the description herein and throughout the claims, the following terms take the meanings explicitly associated herein, unless the context clearly dictates otherwise: the meaning of “a,” “an,” and “the” includes plural reference, the meaning of “in” includes “in” and “on.” Also, as used herein, “PTFE” means polytetrafluoroethylene, “PDMS” means polydimethylsiloxane, and polyimide is a material commercially known as “Kapton.”

U.S. Pat. No. 9,178,446, filed by Wang et al. on Nov. 3, 2015 discloses a triboelectric generator and methods of making the same and is hereby incorporated by reference. U.S. Patent Publication Nos. US-2016-0040648-A1 (published on Feb. 11, 2016), US-2016-0070392-A1 (published on Mar. 10, 2016) and US-2016-0065091-A1 (published on Mar. 3, 2016), all filed by Wang et al., disclose triboelectric generators that employ contact triboelectrification and are hereby incorporated by reference.

As shown in FIGS. 1A-1B, one embodiment of a triboelectric generator **100** includes a first triboelectric member **110**, a second triboelectric member **130** and an elastic member **120** having an undulated shape (such as a wavy shape) disposed there-between. The first triboelectric member **110** and the second triboelectric member **130** each include a substrate **112** (such as an acrylic substrate) and a conductive layer **114** (such as a copper layer) disposed thereon. A triboelectric material layer **116** is disposed on the conductive layer **114**. The triboelectric material layer **116** is made from an insulating material (such as PTFE) that has a first position on a triboelectric series. The triboelectric material layer **116** has a plurality of nanoscale protrusions **118** extending outwardly from a triboelectric material.

The elastic member **120** includes a dielectric elastic material layer **124** (such as a polyimide film, which in one example is Kapton available from DuPont) that has an elasticity that results in the elastic member **120** being deformed when compressed and returning to an original non-deformed shape after being decompressed. Each side of the elastic material layer **124** is coated with a second conductive material layer **122** (which can include, for example, copper) that includes a material having a second position, different from the first position, on the triboelectric series.

As shown in FIG. 1C, the elastic member **120** can be formed in an undulated wavy shape by weaving the elastic material layer **124** between parallel metal rods **140** and heating the elastic material layer **124** to the glass transition temperature of the elastic material layer **124** and then cooling the elastic material layer **124** to below the glass

transition temperature. Once cooled, the elastic material layer **124** will maintain its wavy shape.

One experimental embodiment included a 125 μm thick Kapton film, a 125 μm thick PTFE film, a $\frac{1}{16}$ " thick acrylic substrate and copper. Firstly, the Kapton film was periodically bent into a wavy shape by using a set of metal rods (with diameter of $\frac{1}{4}$ "). Then the set was sent into a muffle oven and baked at 360° C. for 4 hours. Since Kapton film is thermoplastic, it will remain in the wavy shape stably below its glass transition temperature. Then a 200 nm copper layer was sputtered on both sides of the wavy Kapton film as electrodes. Secondly, two slides of PTFE films were prepared by applying inductively coupled plasma (ICP) etching (specifically 15 sccm Ar, 10 sccm O₂ and 30 sccm CF₄ under 400 W RF power and 100 W bias power) on one side of the films and nanostructures were thus obtained, which enhance contact-electrification. Then, a 200 nm thick layer of copper was subsequently sputtered on the other side of the film acting as electrodes. The copper side of the PTFE films was then tightly adhered to two acrylic substrates respectively by using a thin layer of cured PDMS. By sandwiching the Cu-Kapton-Cu wavy core using the two acrylic substrates with PTFE films facing inside and bonding the structures together with electrical tapes, the final device structure was obtained.

Operation of this embodiment is shown in FIGS. 2A-2C, in which a load **210** is electrically coupled between the conductive layers of the triboelectric members **110** and **130** and the conductive layers of the elastic member **120**. Initially, as shown in FIG. 2A, the system is at rest and all of the charges are in balance. As shown in FIG. 2B, when a force is applied to the system (as represented by the arrow), the system compresses the elastic member **120**, which causes increased surface area contact between the elastic member **120** and the triboelectric members **110** and **130**. This results in triboelectric charge transfer there-between and current flow through the loads **210**. When the compressive force is removed, as shown in FIG. 2C, the elastic member **120** returns to its at-rest shape, which reduces contact surface area with the triboelectric members **110** and **130**, and which results in a charge imbalance. This results in reverse current flowing through the loads **210** to return the system to electrical equilibrium.

In operation, once the acrylic substrate is under impact, the wavy core will be compressed in the vertical direction and be extended in the horizontal direction, converting the vertical compressing force into lateral friction between the core and both PTFE surfaces. Also the contact area between PTFE and Cu film is increased and the average distance between the two is reduced. Once the impact is removed, the wavy core will retract on the horizontal direction and extend on the vertical direction, also leading to lateral friction between the core and both PTFE surfaces. Also the contact area between PTFE and Cu film is reduced and the average distance between the two is increased. The working process of triboelectric generator includes two parts: the charge transfer and charge separation. The transfer is accomplished by the lateral friction between the copper thin films, which lose electrons, and the PTFE films, which gain electrons. The charge separation process is accomplished by the change of capacitance between the copper coated on Kapton film and the copper coated on the back side of the PTFE films.

As shown in FIG. 3, a triboelectric generator can be made with a single triboelectric member. In this embodiment, the elastic member **310** is placed against a second substrate **310**.

This embodiment is based on a wavy structured Cu-Kapton-Cu film sandwiched between two flat nanostructured PTFE films for harvesting energy due to mechanical vibration, impacting and compressing using the triboelectric effect. This structure design allows the triboelectric generator to be self-restorable after impact without the use of extra springs and converts direct impact into lateral sliding, which is proved to be a much more efficient friction mode for energy harvesting. In one experimental embodiment, vibrational energy from 5 Hz to 500 Hz was harvested and the generator's resonance frequency was determined at ~100 Hz at a broad full width at half maximum (FWHM) of over 100 Hz, producing an open-circuit voltage of up to 72 V, a short-circuit current of up to 32 μA and a peak power density of 0.4 W/m². The wavy structure of the triboelectric generator can be easily packaged for harvesting the impact energy from water waves, clearly establishing the principle for ocean wave energy harvesting. Considering the advantages of triboelectric generator, such as cost-effectiveness, light weight and easy scaling up, this approach might open the possibility for seeking green and sustainable energy from the ocean using nanostructured materials.

To study the ability of triboelectric generator to power external loads, one experimental embodiment was tested at 100 Hz under variable load resistance. An adjustable resistor was used as the load, providing resistance from as low as 1 K Ω to as high as 100 M Ω . The electrometer was connected in parallel with the resistor to measure the output voltage and was connected in series with the resistor to measure the output current. It was found that output voltage increases with increasing load resistance while the output current increases with decreasing load resistance. Instantaneous peak power density, calculated by $P_d=I^2R/S$, demonstrated that the highest peak power density of 0.4 W/m² was obtained at the load resistance of 5 M Ω .

As shown in FIGS. 4A-4C, one embodiment of a triboelectric generator **400** includes an elastic member that employs an elastic member **424** that has a plurality of three-dimensional shapes extending upwardly from a copper layer in which each of the three-dimensional shapes having an outer surface that includes copper. In the embodiment shown, the three-dimensional shapes are partial spheres **426**, which are in contact with the triboelectric material layer **416** (such as PTFE) of the triboelectric member **410**. As shown in FIG. 4D, each partial sphere **426** can include a PDMS core **430** with a copper coating layer **432**. Returning to FIGS. 4A-4C, the triboelectric member **410** includes a substrate **412**, a conductive layer **414** and a triboelectric material layer **416**. The elastic member **424** is mounted on a substrate **420**. When a compressive force is applied, as shown in FIG. 4B, the partial spheres **426** are compressed, thereby increasing their contact surface area with the triboelectric material layer **416**, which results in contact electrification and current flow through the load **210**. Eventually, the partial spheres **426** will become maximally compressed, as shown in FIG. 4C. Decompression of the system will cause the partial spheres **426** to return to their undeformed shape and reverse current to flow through the load **210** during the decompression process.

As shown in FIGS. 5A-5I, one method for making the partial spheres includes: treating a silicon or quartz substrate **510** with oxygen plasma to flatten its surface and placing a layer of closely packed polystyrene spheres **512** on the substrate **510**. (One method for placing spheres on a substrate is disclosed in U.S. Pat. No. 7,351,607, issued to Wang et al. on Apr. 1, 2008, which is hereby incorporated by reference.) (Experimentally, polystyrene spheres of the fol-

lowing diameters were used: 90 μm, 600 μm, and 3 mm.) A PDMS slurry **514** is placed around the spheres **512** and the PDMS slurry **514** is cured. The cured PDMS layer **514** is lifted from the spheres **512**, thereby leaving a PDMS mold **516** of the spheres. A conductive material layer coating **518** is applied to the mold **516** and a second PDMS slurry **520** is applied to the mold **516**. The PDMS **520** is cured and removed from the mold **514**, thereby leaving the elastic partial spheres **522** employed in the elastic member of the triboelectric generation.

In operation, at the initial state, the top area of Cu-deposited hemispheres-array-structured film created a point of contact with PTFE film, where there is no charge transfer, which results in no electric potential. When a compressive force is applied to the device, the Cu-deposited hemispheres-array-structured film starts to be deformed and dimensional flat contact area is created with PTFE film accordingly. The contact area between the hemispheres-array-structured film and PTFE film depends on the applied compressive force. Positive triboelectric charges on the surface of hemispheres-array-structured film, and negative triboelectric charges on the PTFE film are created by the triboelectric effect. At this stage, the device remains in electrostatic equilibrium state due to negligible dipole moment. As compression on the device is released, a strong dipole moment is formed due to the electrostatic effect, which results in an electrical potential difference between the bottom and top electrodes. Because the Cu-deposited hemispheres-array-structured film has a higher potential than the top Al electrode, electrons start to flow from the top electrode to the bottom electrode through the external circuit to neutralize the negative triboelectric charges in the top electrode, which results in electric signal observed from the device.

Output performance of the device is determined by two dominant effects. One is the triboelectric effect that is created by periodic contacts between two materials that differ in polarity of triboelectricity. Another one is the electrostatic effect that is made by the potential difference between two charged materials when those are mechanically separated.

A micrograph of the nanoscale texture applied to the triboelectric member in the embodiment of FIG. 1A is shown in FIG. 6. A micrograph of the partial spheres used in the embodiment of FIG. 4A is shown in FIG. 7.

The above described embodiments, while including the preferred embodiment and the best mode of the invention known to the inventor at the time of filing, are given as illustrative examples only. It will be readily appreciated that many deviations may be made from the specific embodiments disclosed in this specification without departing from the spirit and scope of the invention. Accordingly, the scope of the invention is to be determined by the claims below rather than being limited to the specifically described embodiments above.

What is claimed is:

1. A method of making a triboelectric generator, comprising the steps of:

- (a) applying a first conductive layer on a selected surface of a first substrate;
- (b) applying a triboelectric material on the conductive layer, the triboelectric material including a first material that has a first position on a triboelectric series, thereby generating a first triboelectric member;
- (c) applying a second conductive layer to a dielectric elastic material having a predefined shape, the second conductive layer including a second material that has a second position, different from the first position, on the triboelectric series, the dielectric elastic material having an elasticity that results in the elastic member returning to the predefined shape after being compressed, thereby generating an elastic member;
- (d) placing the second conductive layer of the elastic member against the triboelectric material of the first triboelectric member; and
- (e) electrically coupling a load between the first conductive layer and the second conductive layer.

2. The method of claim 1, wherein the dielectric elastic material comprises a polyimide film and further comprising the step of making the predefined shape of the dielectric elastic material into an undulated shape.

3. The method of claim 2, wherein the step of making the predefined shape of the dielectric elastic material into an undulated shape comprises the steps of:

- (a) heating the polyimide film until the polyimide film becomes flexible
- (b) weaving the polyimide film between a plurality of parallel metal rods; and
- (c) cooling the polyimide film.

4. The method of claim 1, further comprising the step of forming a nanoscale texture on the first triboelectric member.

5. The method of claim 4, wherein the step of forming a nanoscale texture comprises applying inductively coupled plasma etching to the first triboelectric member to produce a plurality of nanostructures outwardly therefrom.

6. The method of claim 1, wherein the elastic member is made by a process comprising the steps of:

- (a) disposing a plurality of polystyrene spheres on a surface of a substrate;
- (b) surrounding the polystyrene spheres with an uncured PDMS and curing the PDMS;
- (c) separating the PDMS from the polystyrene spheres, thereby generating a mold corresponding to portions of the polystyrene spheres;
- (d) coating the mold with the second conductive layer;
- (e) casting the mold with PDMS and curing the PDMS so as to form partial PDMS spheres surrounded with the conductive film; and
- (f) removing the PDMS spheres surrounded with the conductive film from the mold.

7. The method of claim 6, wherein the second conductive layer comprises copper.

* * * * *